

# AR SERIES ROUTER

## HARDWARE REFERENCE

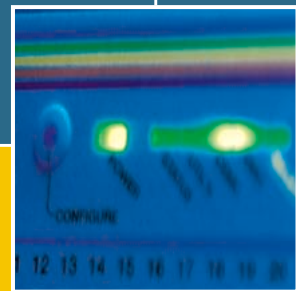
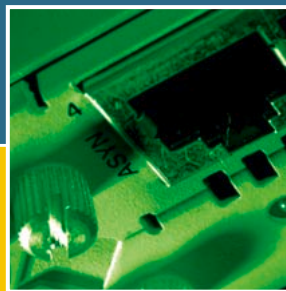

AR Router Hardware Reference  
Document Number C613-03068-00 REV A.

Copyright © 1999-2003 Allied Telesyn International, Corp.  
19800 North Creek Parkway, Suite 200, Bothell, WA 98011, USA.

All rights reserved. No part of this publication may be reproduced without prior written permission from Allied Telesyn.

Allied Telesyn International, Corp. reserves the right to make changes in specifications and other information contained in this document without prior written notice. The information provided herein is subject to change without notice. In no event shall Allied Telesyn be liable for any incidental, special, indirect, or consequential damages whatsoever, including but not limited to lost profits, arising out of or related to this manual or the information contained herein, even if Allied Telesyn has been advised of, known, or should have known, the possibility of such damages.

All trademarks are the property of their respective owners.

## Contents

|  |    |
|--|----|
| Contents .....   | 3  |
| Introduction .....                                     | 5  |
| Models Covered By This Reference .....                 | 6  |
| Where To Find More Information .....                   | 6  |
| Using Windows Terminal and Windows Hyperterminal ..... | 7  |
| Router Start-up .....                                  | 10 |
| Online Documentation .....                             | 15 |
| To Access Online Documentation .....                   | 15 |
| AT-TFTP Server .....                                   | 15 |
| Memory .....   | 17 |
| AR300 Series Routers .....                             | 18 |
| Front and Rear Panels .....                            | 19 |
| The Main System .....                                  | 25 |
| Hardware Features .....                                | 26 |
| AR400 Series Routers .....                             | 34 |
| AR410 and AR410S Routers .....                         | 34 |
| AR450S Router .....                                    | 38 |
| AR700 Series Routers .....                             | 41 |
| AR720 Router .....                                     | 41 |
| AR725 Router .....                                     | 45 |
| AR740 Router .....                                     | 47 |
| AR745 Router .....                                     | 53 |
| PAC Slot .....   | 54 |
| AT-RPS 740 .....                                       | 59 |
| DC supply cables .....                                 | 60 |
| Specifications .....                                   | 61 |
| LEDs .....   | 62 |
| Mini Accelerator Cards (MACs) .....                    | 63 |
| How MACs work .....                                    | 63 |
| Compression .....                                      | 64 |
| Encryption .....                                       | 64 |
| Dual Mode .....  | 65 |
| PCI Accelerator Cards (PACs) .....                     | 65 |
| How PACs work .....                                    | 65 |
| Compression .....                                      | 66 |
| Encryption .....                                       | 67 |
| Dual Mode .....  | 67 |
| Flash Memory .....                                     | 68 |
| Onboard flash .....                                    | 68 |
| Testing Onboard Flash Memory .....                     | 68 |
| CompactFlash .....                                     | 70 |
| Testing CompactFlash .....                             | 71 |
| Interfaces .....                                       | 72 |
| Asynchronous Interfaces .....                          | 72 |
| Synchronous Interfaces .....                           | 74 |
| Modems and NTUs .....                                  | 75 |
| Ethernet Interfaces .....                              | 75 |
| Ethernet Dual 10BASE-T/AUI Interfaces .....            | 76 |
| Basic Rate ISDN Interfaces .....                       | 76 |
| Primary Rate ISDN Interfaces .....                     | 77 |
| Voice Ports .....                                      | 77 |
| Test Facility .....                                    | 78 |
| Asynchronous Interface Tests .....                     | 79 |
| Ethernet LAN Interface Tests .....                     | 79 |
| WAN Port Tests .....                                   | 79 |
| Cables And Loopback Plugs .....                        | 80 |
| Transition Cables for Network Interfaces .....         | 80 |

---

|   |     |
|---|-----|
| ISDN Interface Cables .....                 | 88  |
| Terminal and Modem Cables .....             | 89  |
| Transceivers and AUI Cables .....           | 95  |
| Loopback Plugs for Testing Interfaces ..... | 96  |
| PICs and NSMs .....                         | 100 |
| Restricted Procedures .....                 | 100 |
| Installing a MAC .....                      | 100 |
| Installing a PAC .....                      | 105 |
| Installing a Flash SIMM .....               | 111 |
| AT-AR720 Dip Switch Settings .....          | 112 |
| Diagnostics .....                           | 113 |
| Replacing Boot EPROMs .....                 | 115 |
| Lithium Battery Replacement .....           | 117 |
| Contacting Us .....                         | 120 |

## Introduction

---

This Hardware Reference describes the hardware features of all AR300, AR400, and AR700 Series router models, including information on Mini Accelerator Cards (MACs) and PCI Accelerator Cards (PACs). Hardware and installation information for Port Interface Cards (PICs) and Network Service Modules (NSMs) can be found in their respective Quick Install Guides and Hardware References.



---

*This Reference does not cover software configuration or software installation procedures. For information on software, refer to your router's Software Reference.*

---



---

*This Reference does not cover AR100 Series routers. For information on AR100 Series routers, refer to the AR100 Series Internet Router User Guide or AR100 Series Internet Router Software Reference. These documents can be found on the CD-ROM packaged with your AR100 Series router, or at [www.alliedtelesyn.co.nz/support/ar100/index.html](http://www.alliedtelesyn.co.nz/support/ar100/index.html).*

---

AR300 Series routers have fixed interface configurations and do not have expansion capabilities. Some AR400 Series routers and all AR700 Series routers have expansion bays that accommodate Port Interface Cards (PICs), which provide additional or new interfaces. The AT-AR740 and AT-AR745 routers also have an expansion bay to accommodate a *Network Service Module* (NSM), which either directly provides further interfaces, or provides multiple slots where additional PIC interfaces can be added.

AR300 Series routers, AR400 Series routers, AR720 and AR740 routers have a dedicated Mini Accelerator Card (MAC) slot that accommodates special purpose MAC coprocessor cards. MAC cards provide additional functionality or performance, such as compression or encryption, but do not add extra interfaces.

In addition to a MAC slot, AR740 routers also have a PCI Accelerator Card (PAC) slot. This slot accommodates PACs. Like MACs, PACs provide additional compression and encryption functionality, but do so through a high performance PCI bus.

The AR725 and AR745 routers have a PAC slot only.

## Models Covered By This Reference

---

This Hardware Reference includes information on the following models:

- AR300L(S)
- AR300(S)
- AR310(S)
- AR320
- AR330
- AR350
- AR370(S)
- AR370(U)
- AR390
- AR395
- AR410
- AR410S
- AR450S
- AR720
- AR725
- AR740
- AR745
- AT-RPS 740

Hardware Reference updates can be found at [www.alliedtelesyn.co.nz/documentation/documentation.html](http://www.alliedtelesyn.co.nz/documentation/documentation.html).

## Where To Find More Information

---

The Documentation and Tools CD-ROM bundled with each router contains the complete Document Set for your router and, where applicable, its expansion options. The CD-ROM also includes tools for managing your router.

The Document Set includes:

- The *Safety Booklet* for your router, which provides safety and statutory information.
- The *Quick Install Guide* for your router, which outlines how to install the router.
- The *Quick Start Guide* or *User Guide* for your router, which describes basic configuration procedures.
- The *AR Router Hardware Reference* for your router, which provides detailed information on the hardware features of AR routers.
- The *Software Reference* for your router, which provides detailed information on configuring the router and its software.
- AT-TFTP Server for Windows, for downloading software releases.

- Adobe Acrobat Reader, for viewing online documentation.
- Microsoft Internet Explorer.

The following documents are included if your router has PIC bays or an NSM bay:

- The *Port Interface Card Quick Install Guide*, which outlines the procedure for installing PICs; and the *Port Interface Card Hardware Reference*, which provides detailed information on PICs.

The following documents are included if your router has an NSM bay:

- The *Network Service Module Quick Install Guide*, which outlines the procedure for installing an NSM; and the *Network Service Module Hardware Reference*, which provides detailed information on NSMs.

These documents can also be downloaded from the AR Router Support Site at [www.alliedtelesyn.co.nz/documentation/documentation.html](http://www.alliedtelesyn.co.nz/documentation/documentation.html).



---

*For information on AR100 Series routers, refer to the AR100 Series Internet Router User Guide or AR100 Series Internet Router Software Reference. These documents can be found on the CD-ROM shipped with your AR100 Series router, or at [www.alliedtelesyn.co.nz/support/ar100/index.html](http://www.alliedtelesyn.co.nz/support/ar100/index.html).*

---

## Using Windows Terminal and Windows Hyperterminal

You can use a PC running terminal emulation software as the manager console, instead of a terminal. There are many terminal emulation applications available for PCs, but the most readily available are the Terminal and HyperTerminal applications included in Microsoft Windows 95, 98, 2000, and Windows NT 4.0. In standard Windows installations, HyperTerminal is located in the Start > Programs > Accessories menu.

The key to successful use of terminal emulation software with the router is to configure the software and router with matching communications parameters. The following procedures describe how to configure Windows Terminal and HyperTerminal for the default RS-232 Terminal Port settings on the router, but the same principles apply to other terminal emulation programs.

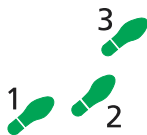

### To configure Windows HyperTerminal for Windows 95, 98, 2000, & NT 4.0.

1. **In Windows, select:**
  - Programs > Accessories > HyperTerminal.
  - Double-click the Hypertrm.exe icon.
2. **In the Connection Description dialog box:**
  - Enter a name for the connection (e.g., AR300LS)
  - Select an icon from the scrolling list.
  - Click "OK".

### 3. In the Phone Number dialog box:

From the “Connect using:” drop-down list, select:

- “Direct to Com *n*” Where “COM *n*” is the COM port on the PC used to connect to the router.
- Click “OK”.



### 4. In the COMn Properties dialog box, set:

- “Bits per second” to 9600.
- “Data bits” to 8.
- “Parity” to None.
- “Stop bits” to 1.
- “Flow control” to Hardware.
- Click “OK”.

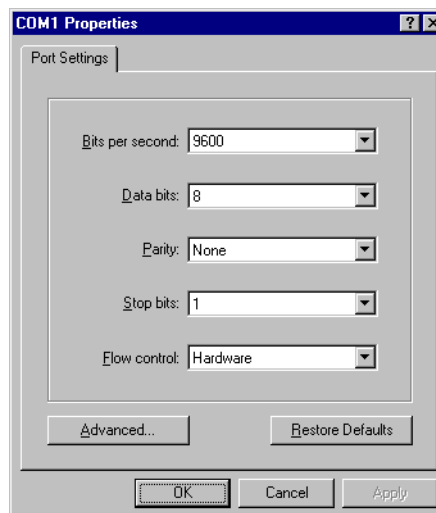

**5. From the File menu, select:**

- “Properties”

In the Connection Properties dialog box, click the Settings tab and set:

- “Function, arrow, and ctrl keys act as” to “Terminal keys”
- “Emulation” to VT100.

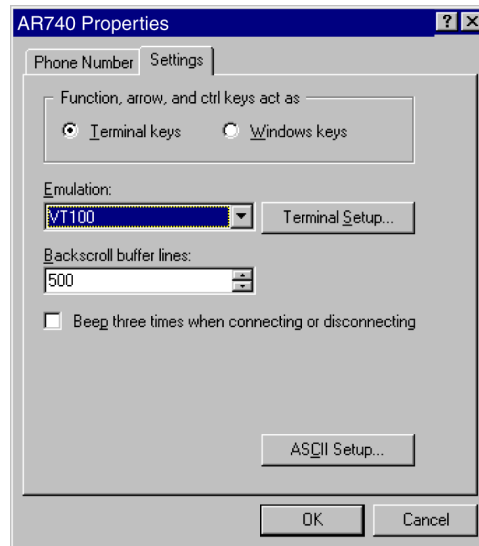
**6. Click “ASCII Setup” to display the ASCII Setup dialog box. Uncheck:**

- “Echo typed characters locally”.
- “Append line feeds to incoming line ends”.

Set other parameters as required.

- Click “OK” twice to close all dialog boxes.

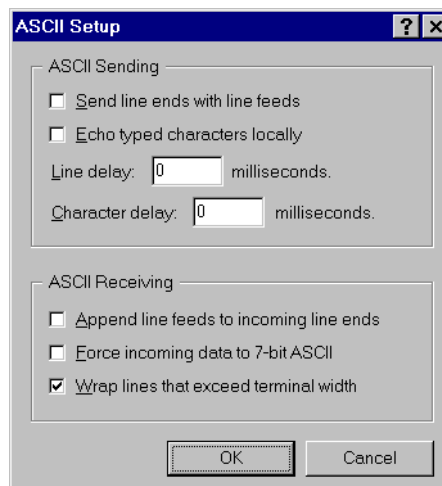

### 7. Save the current session. From the File menu, select:

- “Save”.

This creates a connection icon with the name you assigned in the HyperTerminal group. To use the configuration:

- Double-click the connection icon in the HyperTerminal group.

When the HyperTerminal window appears, press:

- [Enter] a couple of times.

The router’s log in prompt will appear.

## Router Start-up

---

At start-up, the manager can choose to run either the software release stored in EPROM or flash (depending on the model of router), or the software release specified by the INSTALL parameters previously set using the SET INSTALL command. (AR300 Series routers, AR720, and AR740 routers boot from EPROM, while AR400 Series routers, AR725 and AR745 routers boot from flash.)

All code is executed out of system DRAM. At power-up the boot code is loaded from EPROM (or flash for AR400s, the AR725 and AR745) to DRAM. The boot code checks the INSTALL information then reloads DRAM with the selected *temporary, preferred, or default* install release (which is stored in flash) and runs this code.

If the install release is a compressed release, the release is uncompressed as it loads to DRAM. This may take 20–30 seconds. At this point, any required patches are loaded from flash. If a patch is compressed, it is uncompressed as it loads to DRAM. This procedure ensures that the code runs at maximum speed (DRAM is faster than EPROM), and allows updates to be made to the code. Updates can be downloaded over the network from a TFTP server and stored in flash until required at power-up.



---

*See the Software Reference (Chapter 1, Operation), for a description of the downline loading method. The code can also be loaded from the flash memory, under user control. The Operation chapter also has a detailed description of flash memory.*

---

All router software, patches, and configuration settings are stored as files in flash memory. Typically, the following files will be present in flash:

- The current installed software release. Additional software releases may also be present.
- The current installed patch, if any. Additional patches may also be present.
- The online help file. All online help is stored in a separate text file which is designed to be language independent. The online help file is loaded with a software release.
- The boot script `boot.cfg`. The boot script contains standard router commands (executed on start-up to configure the router).
- Additional user-defined configuration scripts containing commands to configure the router for different functions. These scripts are created using the built-in editor, the ADD SCRIPT command, *Scripting*, or the CREATE CONFIG command.



All configuration information is stored in flash memory as configuration scripts. These scripts contain standard router commands. When a configuration command is entered at the command prompt from a terminal, terminal emulation program, or Telnet session, the command only alters the dynamic configuration. This is not saved over a power cycle. To ensure that configuration changes resulting from such commands are retained across a power cycle, the dynamic configuration must be saved as a configuration script, using the `CREATE CONFIG` command.

When the router starts up following either a power cycle or an operator-initiated reboot (using the `RESTART` command), the following sequence of operations is performed:

1. Perform start-up self tests.
2. Load the EPROM release as the `INSTALL` boot into the router's RAM.
3. Prompt the manager for changes to the default start-up procedure:  
`Force EPROM download (Y)?`  
The manager may press one of the keys listed in Table 1 on page 12 to override the default installation procedure.
4. Check the `INSTALL` information to determine which release to load and run, according to the `INSTALL` parameters, and the manager's response to the previous prompt. If none of the keys in Table 1 on page 12 are pressed, the `INSTALL` parameters determine which release and patch are loaded and run.
5. Load the required EPROM or flash release specified by the `INSTALL` parameters as the main boot.
6. Start the router.
7. Execute the boot script (`boot.scp`), if one has been configured.

A series of start-up messages is sent to Port 0 (The console or terminal port).

**Figure 1: Router start-up messages.**

```
INFO: Self tests beginning.
INFO: RAM test beginning.
PASS: RAM test, 4096k bytes found.
INFO: BBR tests beginning.
PASS: BBR test, 128k bytes found.
PASS: BBR test. Battery OK.
INFO: Self tests complete
INFO: Downloading router software.
Force EPROM download (Y) ?
INFO: Initial download succeeded
INFO: Executing configuration script <boot.cfg>
INFO: Router startup complete

Manager >
```

After the self tests are complete, the manager is given the option of forcing a mandatory boot from the EPROM release. The message:

```
Force EPROM download (Y)?
```

is displayed on the terminal connected to the console port (port 0) and the router pauses. If a key is not pressed within a few seconds, the start-up process continues and all steps in the start-up sequence are executed. Pressing selected keys on the terminal immediately after the "Force EPROM download" message is displayed will change the router start-up process (Table 1 on page 12).

**Table 1: Router start-up sequence keystrokes.**

| Pressing key...                   | Forces the router to...  |
|-----------------------------------|--|
| (no key pressed)                  | After a few seconds, the router start up process continues.  |
| [Y]                               | Load the release, without any patches, from EPROM onto the RAM, and run the full release. Go to step 6.  |
| [S]                               | Load and run the release and patch determined by the INSTALL parameters from flash, ignoring any boot script or any previous configuration stored in NVS.  |
| [N]                               | Load from flash to RAM the release and patch determined by the INSTALL parameters, and run using the current configuration stored in NVS (if any), ignoring any boot script.                           |
| [Ctrl/D]                          | Enter diagnostics mode.  |
| Authorised service engineers only | Warning. Using this option may cause the router to cease functioning, may invalidate the product warranty, and may be a breach of the product licence agreement (" <i>Diagnostics</i> " on page A-15). |

During the start-up process the router will generate four different types of messages. All messages are preceded by one of the words INFO, PASS, FAIL, or ERROR. The meaning of these words in the context of the messages is shown in Table 2 on page 12.

**Table 2: Router start-up message classes.**

| Message | Meaning  |
|---------|--|
| INFO    | An informational message that an action has been taken by the system.                                    |
| PASS    | An informational message that a test has been completed successfully.                                    |
| ERROR   | An error message that a test has failed, but the system will continue to operate.                        |
| FAIL    | An error message that a fatal error condition has caused the system to halt in an unrecoverable fashion. |

The possible messages and their meanings are:

```
INFO: Self tests beginning.
      The code loader tests are about to begin.
```

```
INFO: RAM test beginning.
      The RAM tests are about to begin.
```

FAIL: RAM presence, invalid PD bits, SIMM 0.

ERROR: RAM presence, invalid PD bits, SIMM 1.

The presence detect bits for either RAM SIMM stick (Flash memory) had an invalid value. This is fatal for SIMM position 0 and an error for SIMM position 1. If this error occurs then the RAM SIMM stick is not the correct type and should be replaced. The router will function, but with less memory, provided the error occurs in position 1. Errors in position 0 are fatal and will require the stick to be replaced before the router will function.



---

*Unauthorised opening of the router lid may expose you to live components and a risk of injury from electric shock, it may also damage the router and invalidate the product warranty.*

---

FAIL: RAM presence, memory too slow, SIMM 0.

ERROR: RAM presence, memory too slow, SIMM 1.

The presence detect bits for either RAM SIMM stick indicated 100ns memory, which is too slow for effective router operation. This is fatal for SIMM position 0 and an error for SIMM position 1.

FAIL: RAM presence, memory too small, SIMM 0.

ERROR: RAM presence, memory too small, SIMM 1.

The presence detect bits for either RAM SIMM stick indicated memory that is too small to be handled by the hardware. This is fatal for SIMM position 0 and an error for SIMM position 1.

FAIL: RAM presence, no memory present, SIMM 0.

The presence detect bits for SIMM position 0 indicated that there was no SIMM stick present. This is fatal for this position. No error is flagged if this pattern occurs in SIMM position 1, since not having RAM in position 1 is a valid configuration.

PASS: RAM test, 2048k bytes found.

The RAM test passed, and the indicated amount of memory was found and will be used in the router.

ERROR: RAM test 5. Error address = 00345678.

A RAM test failed, at the given address. In the example, it was the fifth test run. The RAM test repeats until it passes, so a number of messages like this may appear. This fault means that the memory system (probably the SIMM stick) is faulty. The SIMM stick should be replaced. If the fault continues, contact your distributor or reseller immediately.

INFO: BBR tests beginning.

The BBR tests are about to begin.

PASS: BBR test. Battery OK.

The BBR battery test passed.

ERROR: BBR Battery low.

The BBR battery test failed, indicating that the battery is running low. The BBR system will need to be replaced. Contact your distributor or reseller.

PASS: BBR test, 256k bytes found.

The BBR size/location test passed, with the indicated amount of BBR found.

FAIL: BBR test. Error address = 12345678.

The BBR size/location test failed at the given location. The test at this location failed, indicating the end of memory, but a valid location was discovered in the 255 long words following this location. The BBR system will need to be replaced. Contact your distributor or reseller.

FAIL: BBR test, only 16k bytes found.

The BBR size/location test completed, but only the displayed amount of memory was found. This amount is less than the minimum required to run the router software.

INFO: Self tests complete.

The start-up tests have finished.

INFO: Downloading router software.

The process of downloading the router software and vector table from ROM is about to begin.

ERROR: Code load retried.

FAIL: Code load failed.

The load of the code from ROM to RAM failed. The load is retried a number of times. Each time a failure occurs the ERROR message is displayed. If the maximum number of attempts is reached, the FAIL message is displayed.

ERROR: Vector load retried.

FAIL: Vector load failed.

The load of the vector table from ROM to RAM failed. The load is retried a number of times. Each time a failure occurs the ERROR message is displayed. If the maximum number of attempts is reached, the FAIL message is displayed. Contact your authorised Allied Telesyn distributor or reseller.

INFO: Initial download succeeded.

The start-up tests and download are complete, and the router software is about to be started. If the default install is a compressed release, the release will now be decompressed. This may take a few seconds.

INFO: Downloading compressed release. This may take up to 1 minute...

INFO: Loading software into memory. This may take up to 1 minute...

The main router software is about to be loaded into RAM. If the release is a compressed release, the release will be decompressed.

FAIL: Unexpected exception. Offset = 40, Addr = 0100045e.

An unexpected exception occurred while the start-up was executing. The vector offset and the program counter when the exception occurred are given in the message. Contact your distributor or reseller.

INFO: Executing configuration script <script-name>

The configuration commands stored in <script-name> are being executed. If an error is found in the script, one or more ERROR messages will be displayed.

INFO: Router startup complete.

The start-up process is complete and the router is now operational.

## Online Documentation

---

This section provides a step-by-step guide to accessing online documentation. Adobe Acrobat Reader must be installed to view the online documentation.

### To Access Online Documentation

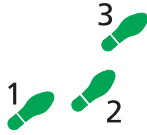

**To use the CD-ROM, follow these steps:**

**1. Insert your router's Documentation and Tools CD-ROM in the CD-ROM drive.**

**2. If the Welcome screen does not appear.**

Select "Run" from the Start Menu (Windows 95, 98, 2000 or NT 4.0).

Type d:\start.exe (where d: is the CD-ROM drive letter) and click OK.

**3. To view a document.**

Click on the document title.

**4. To navigate around PDF documents.**

Use the toolbar buttons, keyboard shortcuts, or commands from the Document menu to page through the document.

Click on a bookmark, thumbnail or hypertext link to jump to a specific section or topic.

Use the Search command to search for keywords or phrases.

For more information about using the Adobe Acrobat Reader, select "Reader Guide" from the Help menu.

**5. To install any of the tools included on the CD-ROM.**

Click on a link in the Welcome screen.

## AT-TFTP Server

---

This section provides information on how to access and use AT-TFTP Server. AT-TFTP Server can be used to transfer configuration files as well as to download software patches and releases.

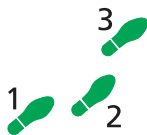

**To use AT-TFTP Server, follow these steps:**

**1. If AT-TFTP Server has not yet been installed.**

Install it now from the your router's Documentation and Tools CD-ROM.

To install AT-TFTP server:

Choose AT-TFTP Server from the Start > Programs > Allied Telesyn > AT-TFTP Server menu.

**2. To set preferences for the AT-TFTP Server.**

Select "Options" from the File menu to display the "Set Preferences" dialog box.

The "Default file transfer directory" field specifies the directory that AT-TFTP Server will read from or write to for file requests that do not include a directory specification.

To prevent unauthorised access to private directories, enter a path name in the "Restrict to directory" field. AT-TFTP Server will use only the specified directory, even if file requests contain references to other directories.

Select "Read only" to prevent files being written to the PC. To use the PC to archive router scripts created using the router's CREATE CONFIG command, select "Read Write".

Make any required changes and click "OK".

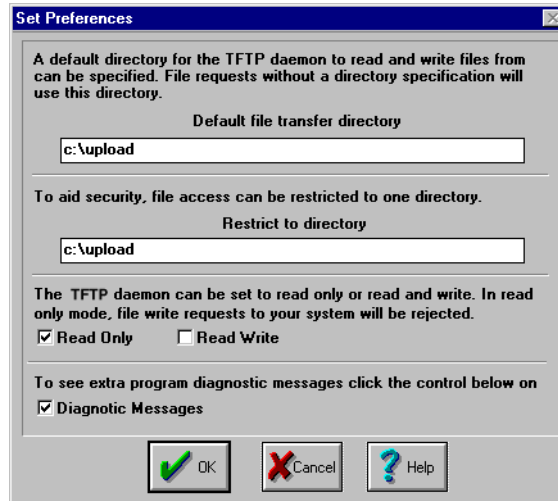

### 3. To load a file from AT-TFTP Server to the router.

On a terminal connected to the router, type the command:

```
LOAD METHOD=TFTP FILE=filename SERVER=ipadd DEST=FLASH
```

where *filename* is the name of the file to download and *ipadd* is the IP address of the PC running AT-TFTP Server.

### 4. To save a TFTP Server log.

Select "Save As" from the File menu.

TFTP requests are logged to the AT-TFTP Server main window.

## Memory

All AR300 Series routers, except the AR390 and AR395, have 8MB of fixed (non-expandable) DRAM. The AR390, AR395, AR410, AR410S, AR720, and AR740 routers have 16MB of fixed (non-expandable) DRAM.

The AR450S has 64MB of SDRAM provided on a single DIMM. 128MB and 256MB ECC SDRAM are also supported on the AR450S. The AR725 and AR745 routers have 128MB of SDRAM DIMMs. Other sizes are supported, e.g. 256 and 512MB See your authorised Allied Telesyn distributor or reseller for upgrade options. Other supplier's DIMMs are not approved, and therefore not supported, but may function correctly. AR725 and AR745 routers also have a slot for compact flash cards. See "Flash Memory" on page 68 for more information on flash memory.

The amount of DRAM present in a router can be checked using the command:

```
SHOW SYSTEM
```

This will produce a display like that shown in Figure 2 on page 17. The *DRAM* and *FLASH* fields show the amounts of DRAM and flash memory, respectively.

**Figure 2: Example output from the SHOW SYSTEM command.**

```

Router System Status                               Time 17:10:06 Date 25-Sep-1999.
Board      ID  Bay Board Name                               Rev    Serial number
-----
Base       62           AR720                               M1-0   6845218
IC Module  40   0  AR022 PIC Eth                               M2-0   6844595
IC Module  38   1  AR023 PIC Sync                             M1-1   6844715
MAC        67           AR012 CMAC                             M2-0   33636409
-----
Memory -   DRAM : 16384 kB   FLASH :  4096 kB
-----
SysDescription
CentreCOM AR720 version 1.8.1-00 08-Sep-1999
SysContact
David Johns, ext 8331
SysLocation
Laboratory, First Floor, Head Office Building
SysName
LAB
SysUpTime
250074 ( 00:41:40 )
Software Version: 1.8.1-00 08-Sep-1999
Release Version : 1.8.1-00 08-Sep-1999
Patch Installed : NONE
Territory      : europe
Help File      : help.hlp

Boot configuration file: load.cfg (exists)
Current configuration: load.cfg
Security Mode   : Disabled

Patch files
Name           Device    Size    Version
-----
52772-02.paz   flash    94856   7.7.2-2
-----

```

## AR300 Series Routers

The AR300 Series comprises a family of fixed function routers. Models are distinguished by the type of WAN port on the base CPU card and the number of analogue voice ports supported (Table 3 on page 18).

**Table 3: Interface configurations for AR300 Series routers.**

| AR300 Series Model | Ethernet LAN Ports | Asynchronous Ports | ISDN Ports                            | Synchronous Ports <sup>1</sup> | Analogue Voice Ports | Expansion Capabilities |
|--------------------|--------------------|--------------------|---------------------------------------|--------------------------------|----------------------|------------------------|
| AT-AR300L(S)       | 1                  | 1                  | 1 BRI S/T<br>(2 B + 1 D)              | -                              | -                    | 1 MAC card slot        |
| AT-AR300(S)        | 1                  | 1                  | 1 BRI S/T<br>(2 B + 1 D)              | -                              | 2                    | 1 MAC card slot        |
| AT-AR310(S)        | 1                  | 1                  | 1 BRI S/T<br>(2 B + 1 D)              | -                              | 4                    | 1 MAC card slot        |
| AT-AR320           | 2                  | 2                  | -                                     | -                              | -                    | 1 MAC card slot        |
| AT-AR330           | 2                  | 2                  | -                                     | 1                              | -                    | 1 MAC card slot        |
| AT-AR350           | 1                  | 2                  | -                                     | 1                              | -                    | 1 MAC card slot        |
| AT-AR370(S)        | 1                  | 2                  | 2 BRI S/T<br>(2 B + 1 D) <sup>2</sup> | 1                              | -                    | 1 MAC card slot        |
| AT-AR370(U)        | 1                  | 2                  | 1 BRI U<br>(2 B + 1 D)                | 1                              | -                    | 1 MAC card slot        |
| AT-AR390           | 1                  | 2                  | 1 G.703 <sup>3</sup>                  | -                              | -                    | 1 MAC card slot        |
| AT-AR395           | 1                  | 2                  | 1 PRI<br>(30 B + 1 D)                 | -                              | -                    | 1 MAC card slot        |

1. Universal AMPLIMITE connector supports RS-232/V.28, V.25 and X.21 standards in both DTE and DCE modes.

2. BRI interfaces are daisy-chained to allow multiple ISDN devices to be connected to the S/T bus.

3. 1 × 2048Kbps or n × 64Kbps.

AR300 Series routers have the following standard interfaces:

- 0, 1, or 2 WAN ports. All models except the AT-AR320 have an ISDN Basic Rate S/T or U port and/or a synchronous port, or a G.703/Primary Rate ISDN port. The AT-AR320 has no WAN ports.
- 1 or 2 asynchronous ports with DB9 connectors. The AT-AR300L(S), AT-AR300(S) and AT-AR310(S) have female connectors. All other models have male connectors.
- 1 Ethernet LAN 10BASE-T port (except the AT-AR320 and AT-AR330, which have two Ethernet LAN 10BASE-T ports).
- Voice ports, on the AT-AR300(S) and AT-AR310(S).

In addition, AR300 Series routers have a dedicated MAC slot which can accommodate any of the following MACs:

- AT-AR010 EMAC, Encryption MAC.
- AT-AR011 ECMAC Compression/Encryption MAC
- AT-AR011 V2 ECMAC Compression/Encryption MAC.
- AT-AR012 CMAC, Compression MAC.

## Front and Rear Panels

The following figures and tables show the front and rear panels, and the functions of the front panel LEDs, for each AR300 Series router.

| AR300 Series Model                         | Front and Rear Panel View | LED Functions      |
|--|---------------------------|--------------------|
| AT-AR300L(S)<br>AT-AR300(S)<br>AT-AR310(S) | Figure 3 on page 19       | Table 4 on page 20 |
| AT-AR320<br>AT-AR330                       | Figure 4 on page 20       | Table 5 on page 21 |
| AT-AR350                                   | Figure 5 on page 21       | Table 6 on page 22 |
| AT-AR370(S)                                | Figure 6 on page 22       | Table 7 on page 23 |
| AT-AR370(U)                                | Figure 7 on page 23       | Table 8 on page 24 |
| AT-AR390<br>AT-AR395                       | Figure 8 on page 24       | Table 9 on page 25 |

The AT-AR300L(S), AT-AR300(S), and AT-AR310(S) are identical except for the number of voice ports. The AT-AR300L(S) has no voice ports. The AT-AR300(S) has two voice ports. And the AT-AR310(S) has four voice ports.

The AT-AR320 and AT-AR330 router are identical, except that the AT-AR330 has a synchronous port.

Figure 3: Front and rear panels of the AT-AR300L(S)/AT-AR300(S)/AT-AR310(S) router.

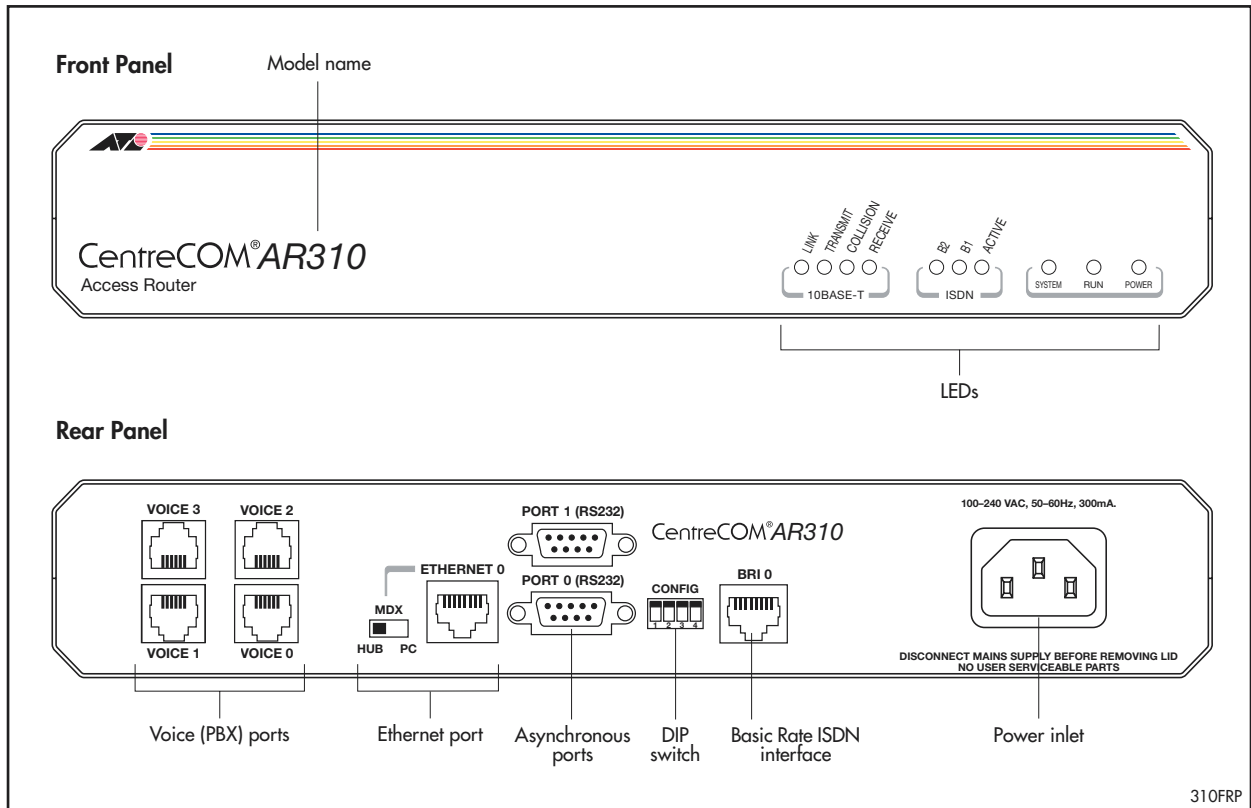

**Table 4: Functions of the front panel LEDs on the AT-AR300L(S)/AT-AR300(S)/AT-AR310(S) router.**

| LED               | Function  |
|-------------------|---|
| LAN Link          | Lit when the Ethernet interface is connected to a device (e.g., a hub), which is generating link pulses. This LED is normally lit.  |
| LAN Txd           | Lit when data is being transmitted over the Ethernet interface.   |
| LAN Coll (yellow) | Lit when a collision is detected on the Ethernet interface.   |
| LAN Rxd           | Lit when data is being received on the Ethernet interface.  |
| ISDN B2           | Lit when data or voice calls are being transmitted over the B2 channel of the ISDN interface.   |
| ISDN B1           | Lit when data or voice calls are being transmitted over the B1 channel of the ISDN interface.   |
| ISDN Active       | Lit when the BRI has successfully completed the exchange of INFO 1 and INFO 2 signals, and INFO 3 and INFO 4 signals are present on the link. This means that the ISDN interface is correctly connected to a working NT device.                                 |
| System (red)      | This LED is not normally lit. It is used to signal various system conditions (e.g., when the processor executes the reboot sequence). Generally it signals a possible fault condition, but it will light briefly during power-up and operator initiated reboot. |
| Run               | Lit when the internal processor is executing code. If the processor stops for any reason (a fault condition), then the LED will not be lit.   |
| Power             | Lit when power is supplied and the router is switched on.   |

**Figure 4: Front and rear panels of the AT-AR320/AT-AR330 router.**

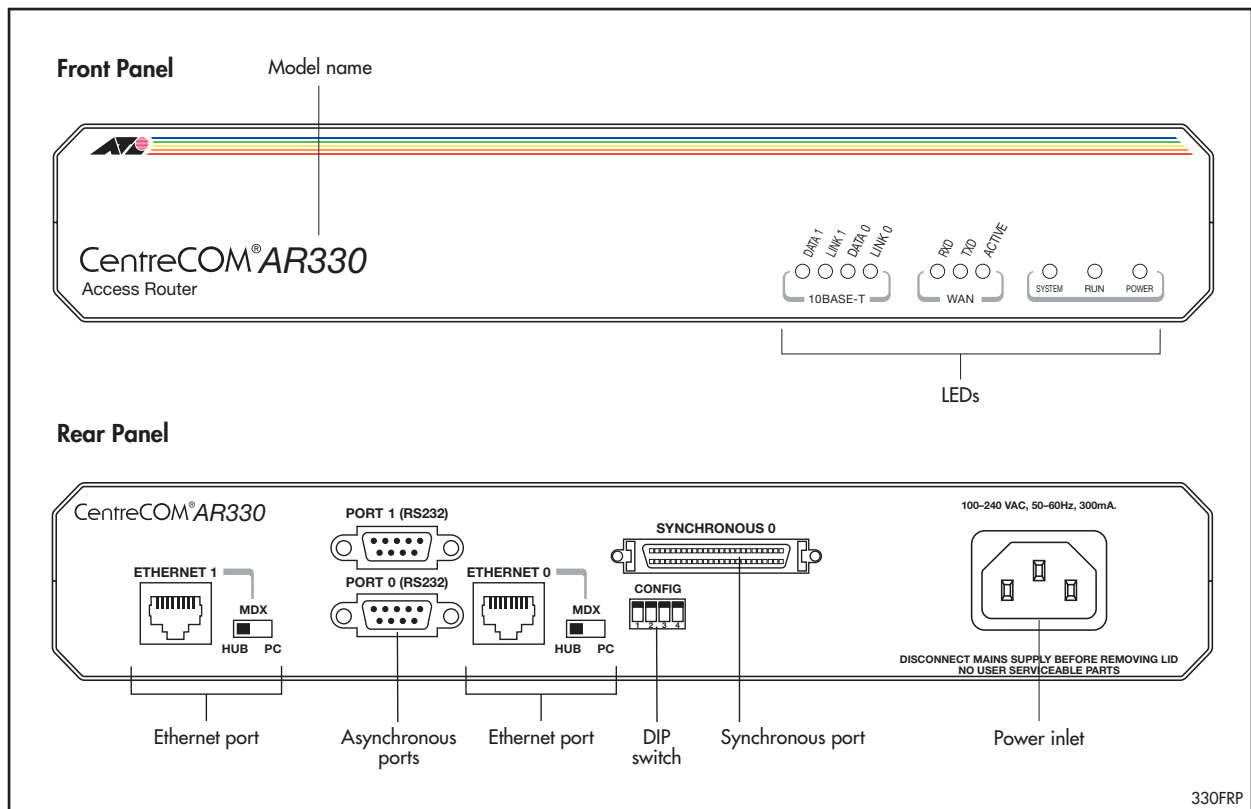

**Table 5: Functions of the front panel LEDs on the AT-AR320/AT-AR330 router.**

| LED          | Function  |
|--------------|---|
| LAN Data 1   | Lit when data is being transmitted over the Ethernet 1 interface.   |
| LAN Link 1   | Lit when the Ethernet 1 interface is connected to a device (e.g., a hub), which is generating link pulses. This LED is normally lit.  |
| LAN Data 0   | Lit when data is being transmitted over the Ethernet 0 interface.   |
| LAN Link 0   | Lit when the Ethernet 0 interface is connected to a device (e.g., a hub), which is generating link pulses. This LED is normally lit.  |
| WAN Rxd      | Lit when data is being received over the synchronous interface.   |
| WAN Txd      | Lit when data is being transmitted over the synchronous interface.  |
| WAN Active   | Lit when a higher layer module (e.g., PPP) has attached to the interface and DCD or its analog ("I" for X.21) is active. This usually indicates that the NTU or DSU/CSU is connected to a correctly provisioned data circuit.                                   |
| System (red) | This LED is not normally lit. It is used to signal various system conditions (e.g., when the processor executes the reboot sequence). Generally it signals a possible fault condition, but it will light briefly during power-up and operator initiated reboot. |
| Run          | Lit when the internal processor is executing code. If the processor stops for any reason (a fault condition), then the LED will not be lit.   |
| Power        | Lit when power is supplied and the router is switched on.   |

**Figure 5: Front and rear panels of the AT-AR350 router.**

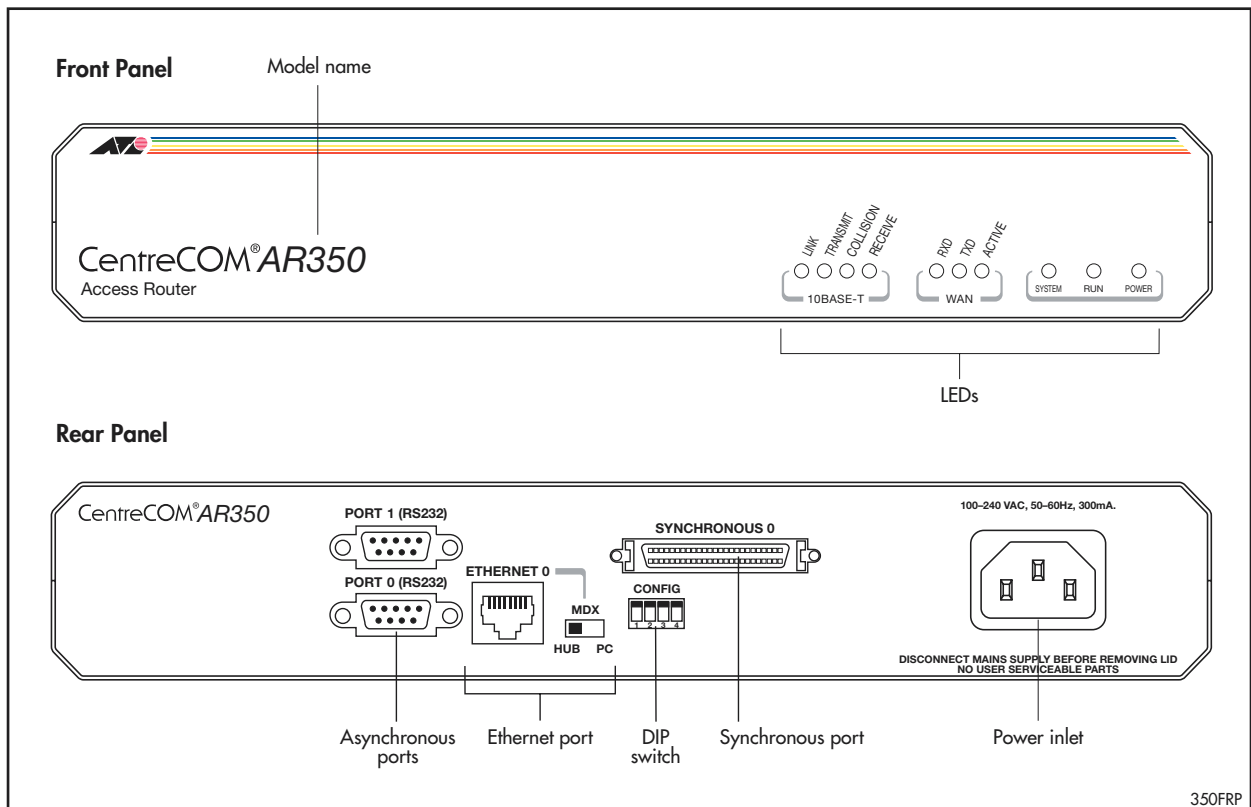

**Table 6: Functions of the front panel LEDs on the AT-AR350 router.**

| LED               | Function  |
|-------------------|---|
| LAN Link          | Lit when the Ethernet interface is connected to a device (e.g., a hub), which is generating link pulses. This LED is normally lit.  |
| LAN Txd           | Lit when data is being transmitted over the Ethernet interface.   |
| LAN Coll (yellow) | Lit when a collision is detected on the Ethernet interface.   |
| LAN Rxd           | Lit when data is being received on the Ethernet interface.  |
| WAN Rxd           | Lit when data is being received over the synchronous interface.   |
| WAN Txd           | Lit when data is being transmitted over the synchronous interface.  |
| WAN Active        | Lit when a higher layer module (e.g., PPP) has attached to the interface and DCD or its analog ("I" for X.21) is active. This usually indicates that the NTU or DSU/CSU is connected to a correctly provisioned data circuit.                                   |
| System (red)      | This LED is not normally lit. It is used to signal various system conditions (e.g., when the processor executes the reboot sequence). Generally it signals a possible fault condition, but it will light briefly during power-up and operator initiated reboot. |
| Run               | Lit when the internal processor is executing code. If the processor stops for any reason (a fault condition), then the LED will not be lit.   |
| Power             | Lit when power is supplied and the router is switched on.   |

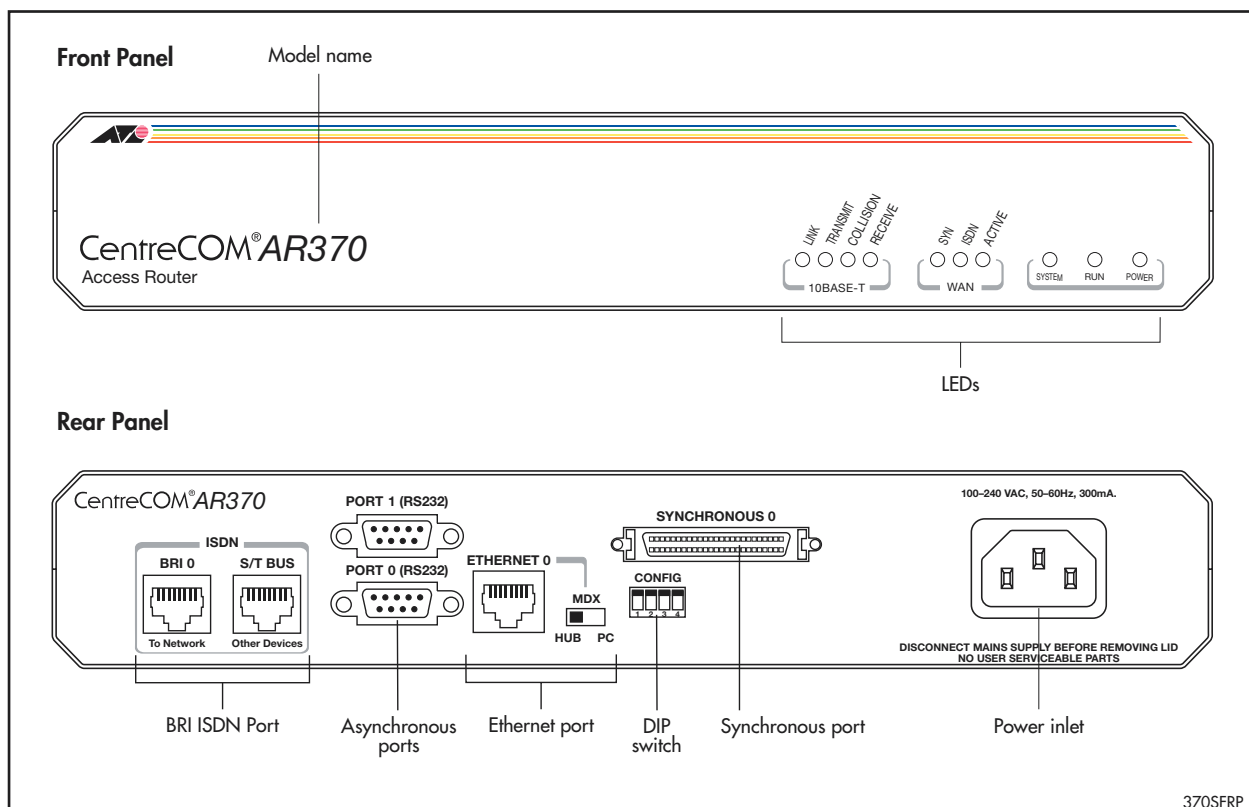
**Figure 6: Front and rear panels of the AT-AR370(S) router.**

**Table 7: Functions of the front panel LEDs on the AT-AR370(S) router.**

| LED               | Function  |
|-------------------|---|
| LAN Link          | Lit when the Ethernet interface is connected to a device (e.g., a hub), which is generating link pulses. This LED is normally lit.  |
| LAN Txd           | Lit when data is being transmitted over the Ethernet interface.   |
| LAN Coll (yellow) | Lit when a collision is detected on the Ethernet interface.   |
| LAN Rxd           | Lit when data is being received on the Ethernet interface.  |
| WAN Syn           | Lit when data is being transmitted or received over the synchronous interface.  |
| WAN ISDN          | Lit when data is being transmitted or received over the ISDN interface.   |
| WAN Active        | Lit when the BRI has successfully completed the exchange of INFO 1 and INFO 2 signals, and INFO 3 and INFO 4 signals are present on the link. This means that the ISDN interface is correctly connected to a working NT device.                                 |
| System (red)      | This LED is not normally lit. It is used to signal various system conditions (e.g., when the processor executes the reboot sequence). Generally it signals a possible fault condition, but it will light briefly during power-up and operator initiated reboot. |
| Run               | Lit when the internal processor is executing code. If the processor stops for any reason (a fault condition), then the LED will not be lit.   |
| Power             | Lit when power is supplied and the router is switched on.   |

**Figure 7: Front and rear panels of the AT-AR370(U) router.**

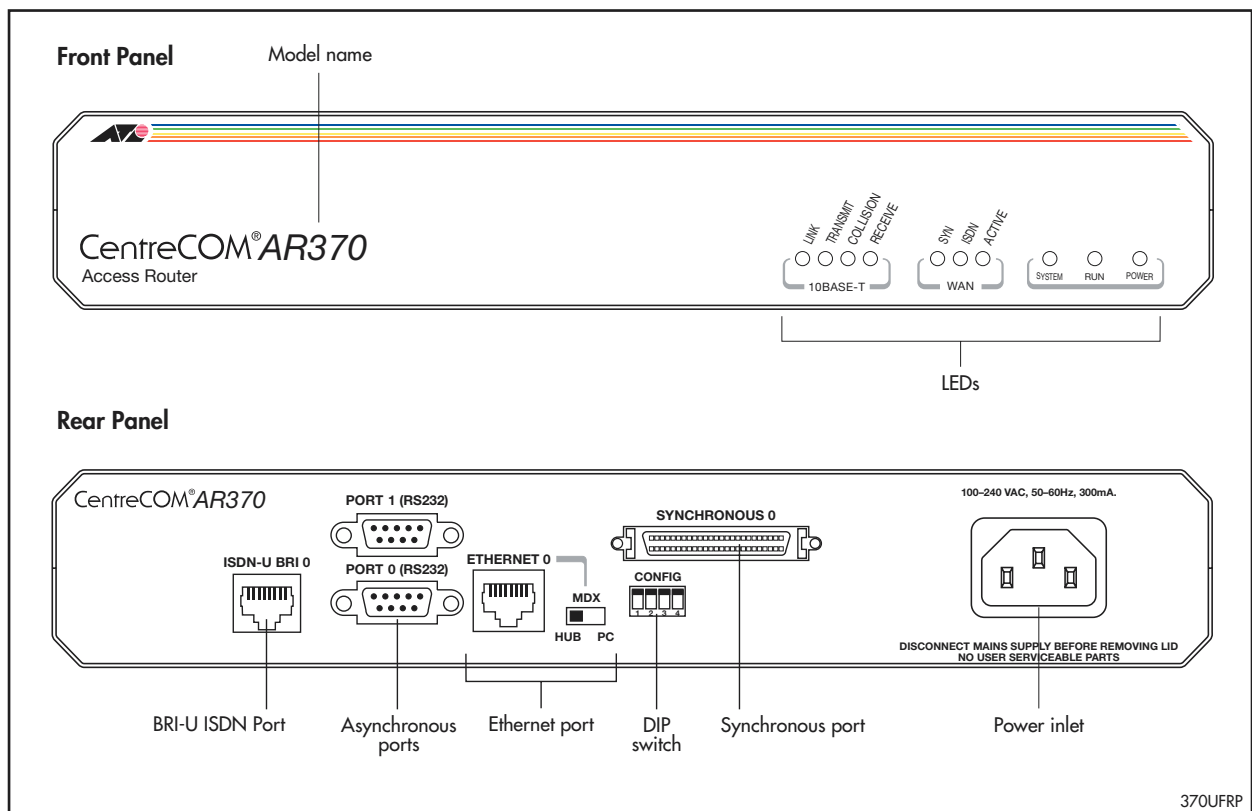

**Table 8: Functions of the front panel LEDs on the AT-AR370(U) router.**

| LED               | Function  |
|-------------------|---|
| LAN Link          | Lit when the Ethernet interface is connected to a device (e.g., a hub), which is generating link pulses. This LED is normally lit.  |
| LAN Txd           | Lit when data is being transmitted over the Ethernet interface.   |
| LAN Coll (yellow) | Lit when a collision is detected on the Ethernet interface.   |
| LAN Rxd           | Lit when data is being received on the Ethernet interface.  |
| WAN Syn           | Lit when data is being transmitted or received over the synchronous interface.  |
| WAN ISDN          | Lit when data is being transmitted or received over the ISDN interface.   |
| WAN Active        | Lit when the U interface is in the <i>Activated</i> state (i.e., it is fully operational at layer 1).   |
| System (red)      | This LED is not normally lit. It is used to signal various system conditions (e.g., when the processor executes the reboot sequence). Generally it signals a possible fault condition, but it will light briefly during power-up and operator initiated reboot. |
| Run               | Lit when the internal processor is executing code. If the processor stops for any reason (a fault condition), then the LED will not be lit.   |
| Power             | Lit when power is supplied and the router is switched on.   |

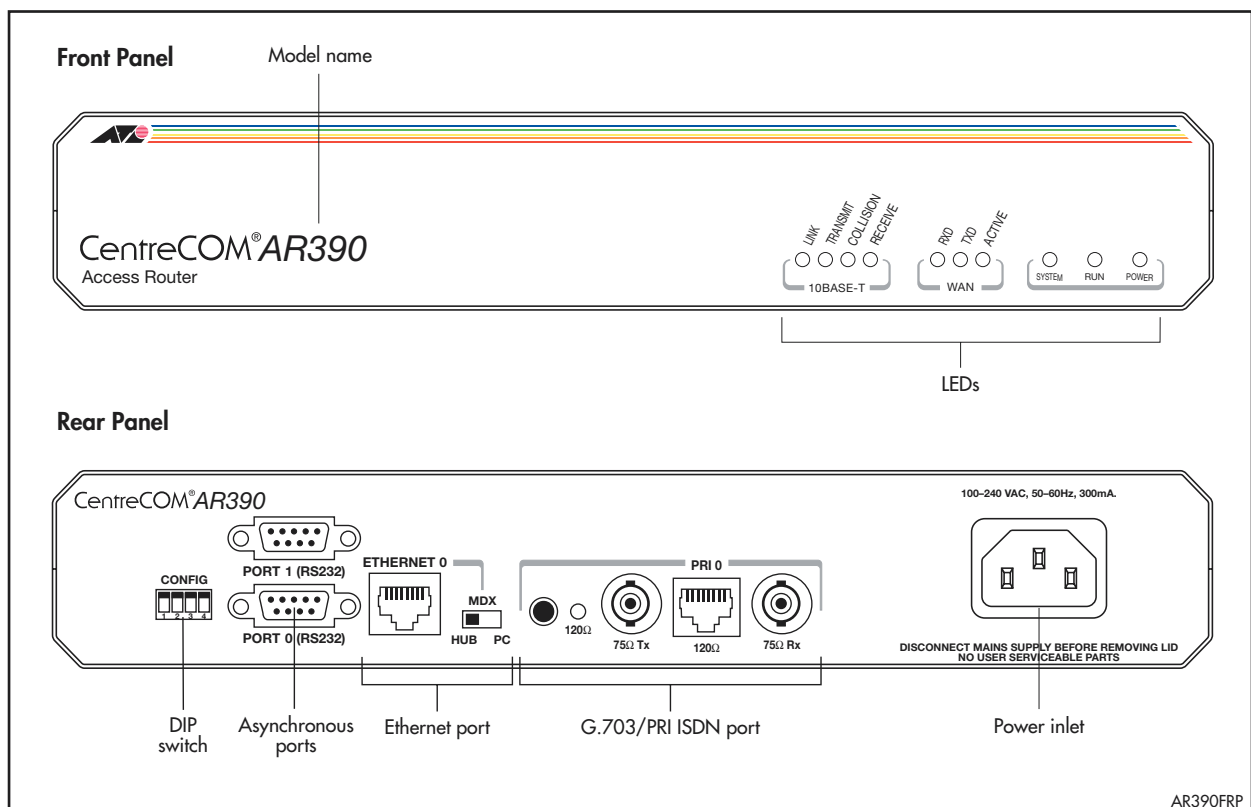
**Figure 8: Front and rear panels of the AT-AR390 and AT-AR395 routers.**

**Table 9: Functions of the front and rear panel LEDs on the AT-AR390 and AT-AR395 routers.**

| LED               | Function  |
|-------------------|---|
| LAN Link          | Lit when the Ethernet interface is connected to a device (e.g., a hub), which is generating link pulses. This LED is normally lit.  |
| LAN Txd           | Lit when data is being transmitted over the Ethernet interface.   |
| LAN Coll (yellow) | Lit when a collision is detected on the Ethernet interface.   |
| LAN Rxd           | Lit when data is being received on the Ethernet interface.  |
| WAN Rxd           | Lit when data is being transmitted over the G.703/PRI ISDN interface.   |
| WAN Txd           | Lit when data is being transmitted over the G.703/PRI ISDN interface.   |
| WAN Active        | Lit whenever operational (i.e., no RAI or AIS set) frames are being received on the G.703/PRI ISDN interface.   |
| System (red)      | This LED is not normally lit. It is used to signal various system conditions (e.g., when the processor executes the reboot sequence). Generally it signals a possible fault condition, but it will light briefly during power-up and operator initiated reboot. |
| Run               | Lit when the internal processor is executing code. If the processor stops for any reason (a fault condition), then the LED will not be lit.   |
| Power             | Lit when power is supplied and the router is switched on.   |
| 120Ω (rear panel) | Lit when the 120Ω interface type is selected via the push button.   |

## The Main System

The main features of the AR300 Series base CPU card are:

- 68360 processor.
- 512K of EPROM.
- 8 MBytes of DRAM.
- 2 MBytes of flash memory.
- 1 or 2 Ethernet LAN 10BASE-T ports.
- 1 or 2 RS-232 asynchronous serial ports.
- 1 Basic Rate ISDN S/T port, on models AT-AR300L(S), AT-AR300(S) and AT-AR310(S).
- 1 Basic Rate ISDN U interface port on model AT-AR370(U).
- 1 G.703/Primary Rate ISDN port, on models AT-AR390 and AT-AR395.
- 1 high speed synchronous serial port, on models AT-AR350, AT-AR370(S), and AR370(U).
- 0, 2, or 4 analogue voice ports.
- 1 MAC compression/encryption card slot.

The asynchronous serial ports can be used as general purpose ports for terminals, printers, or modems. Port 0 can optionally be used for diagnostics or can automatically output the router start-up messages, by altering the DIP switch settings described in Table 10 on page 26.

Set asynchronous port default to:

- 9600 bps
- 8 data bits
- 1 stop bit
- No parity
- Hardware flow control.

## Hardware Features

All models have a DIP switch, which is located on the router's rear panel. DIP switch functions are shown in Table 10 on page 26.

**Table 10: Functions of the rear panel DIP switch on AR300 Series routers.**

| DIP Switch Settings |     |     |     | Function  |
|---------------------|-----|-----|-----|---|
| 1                   | 2   | 3   | 4   |   |
| Any                 | Any | Any | On  | Diagnostics                                     |
| Off                 | Off | Off | Off | Normal boot (default)                           |
| On                  | Off | Off | Off | Reserved  |
| Off                 | On  | Off | Off | Remote configuration                            |
| On                  | On  | Off | Off | Reserved  |
| Off                 | Off | On  | Off | Factory test mode                               |
| On                  | Off | On  | Off | Remote configuration if no configuration script |
| Off                 | On  | On  | Off | Factory test mode                               |
| On                  | On  | On  | Off | Reserved  |

The following figures and tables show the layout of the base CPU board, and the locations and functions of the board-mounted jumpers, for each AR300 Series router:

| AR300 Series Model                         | CPU Board Layout     | Jumper Functions              |
|--|----------------------|-------------------------------|
| AT-AR300L(S)<br>AT-AR300(S)<br>AT-AR310(S) | Figure 9 on page 27  | Table 11 on page 27           |
| AT-AR320<br>AT-AR330                       | Figure 10 on page 28 | No user-configurable jumpers. |
| AT-AR350                                   | Figure 11 on page 29 | No user-configurable jumpers. |
| AT-AR370(S)                                | Figure 12 on page 30 | Table 12 on page 30           |
| AT-AR370(U)                                | Figure 13 on page 31 | Table 13 on page 31           |
| AT-AR390<br>AT-AR395                       | Figure 14 on page 32 | Table 14 on page 32           |



***All jumpers should be left in the factory default positions unless you are advised otherwise by your authorised Allied Telesyn distributor or reseller. Jumpers should only be replaced by authorised service personnel. Unauthorised opening of the router lid may cause danger of injury from electric shock, damage to the router, and invalidation of the product warranty.***

**Figure 9: Location of main components on the AT-AR300L(S), AT-AR300(S), and AT-AR310(S) base CPU cards.**

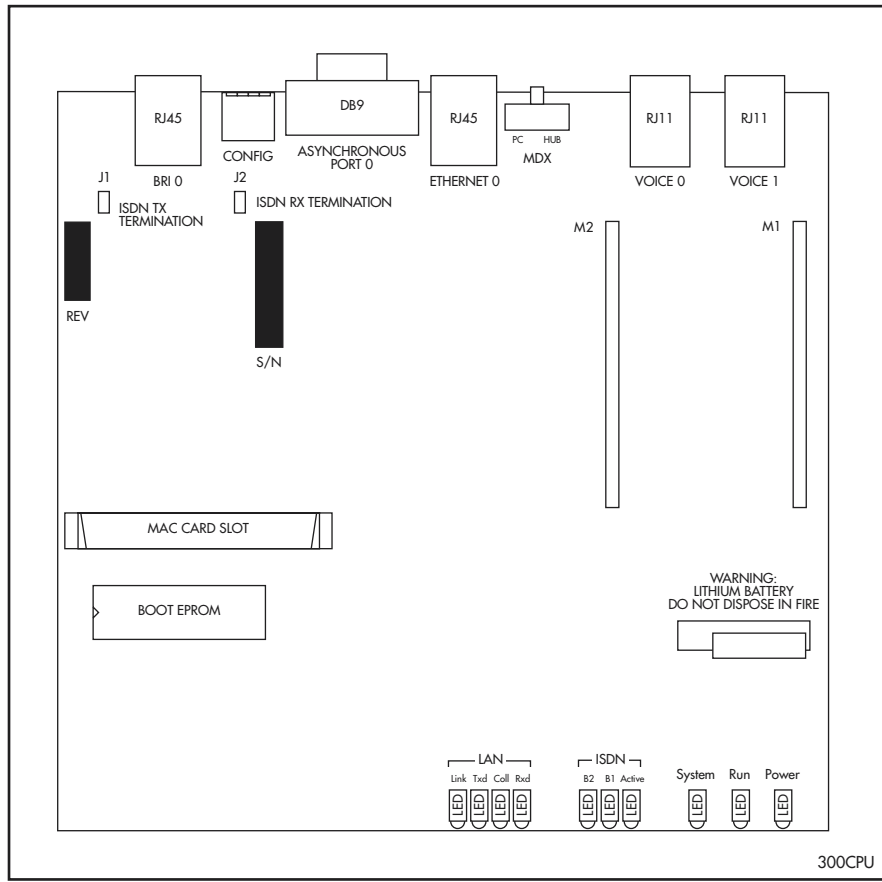

**Table 11: Functions of the jumpers on the AT-AR300L(S), AT-AR300(S), and AT-AR310(S) base CPU cards.**

| Jumper | Function            | Factory Default                 |
|--------|---------------------|---------------------------------|
| J1     | BRI Tx termination. | Not installed (no termination). |
| J2     | BRI Rx termination  | Not installed (no termination). |

Figure 10: Location of main components on the AT-AR320, AT-AR320, and AT-AR330 base CPU cards.

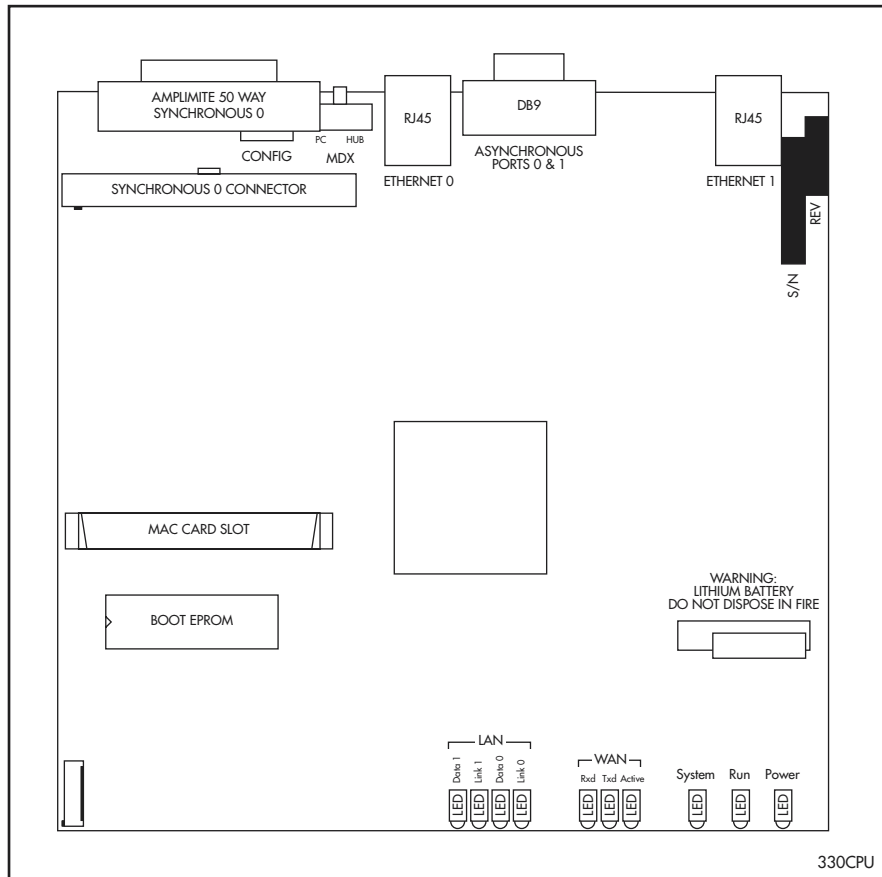

Figure 11: Location of main components on the AT-AR350 base CPU card.

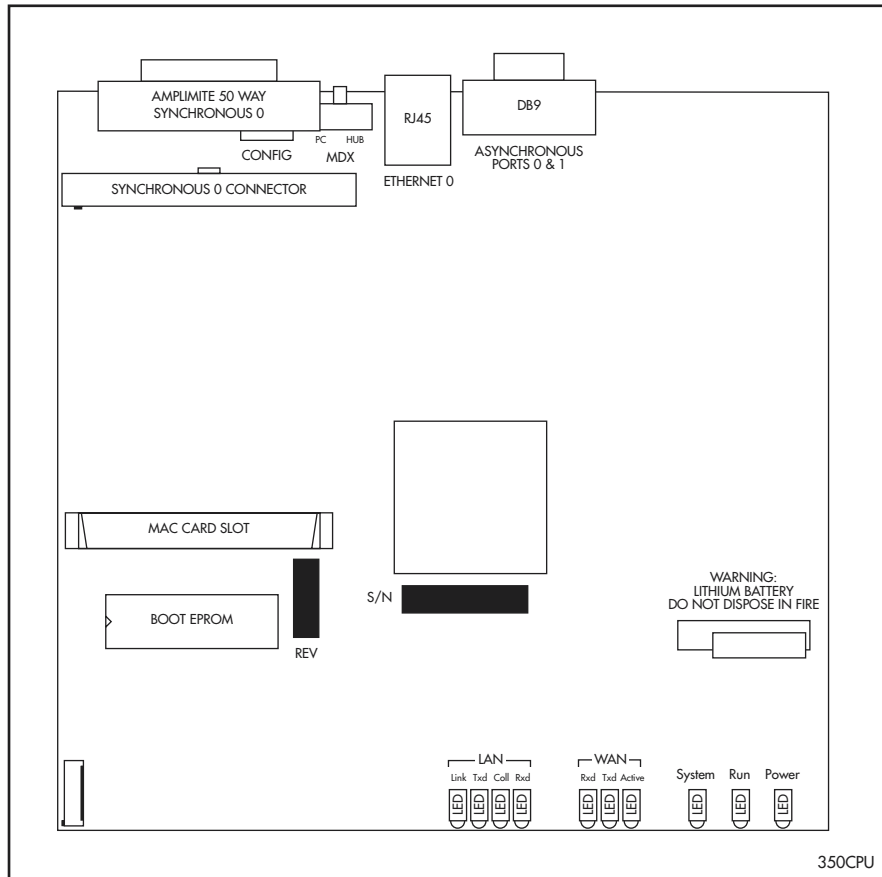

Figure 12: Location of main components on the AT-AR370(S) base CPU card.

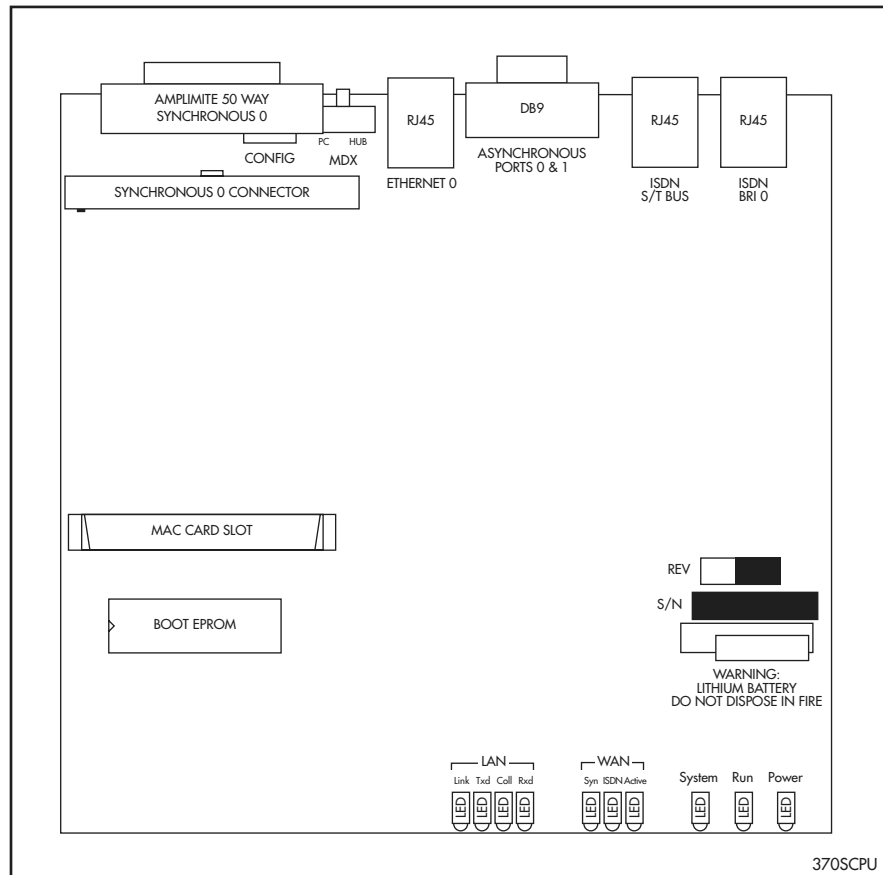

Table 12: Functions of the jumpers on the AT-AR370(S) base CPU cards.

| Jumper | Function           | Factory Default                 |
|--------|--------------------|---------------------------------|
| J1     | BRI Tx termination | Not installed (no termination). |
| J2     | BRI Rx termination | Not installed (no termination). |

Figure 13: Location of main components on the AT-AR370(U) base CPU card.

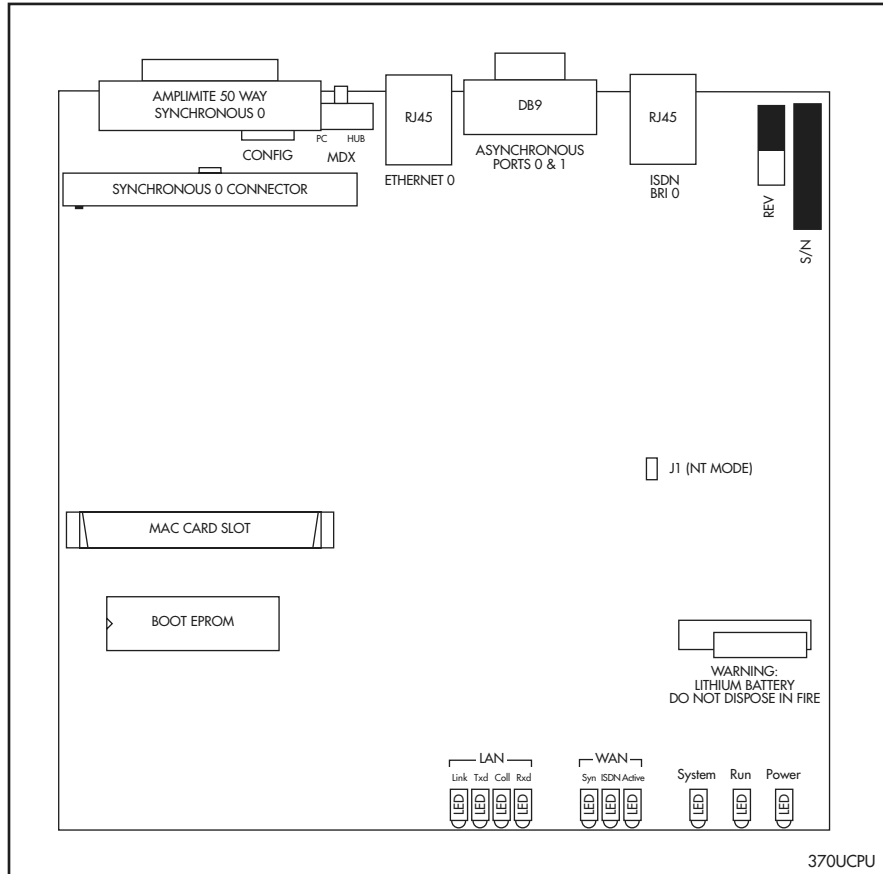
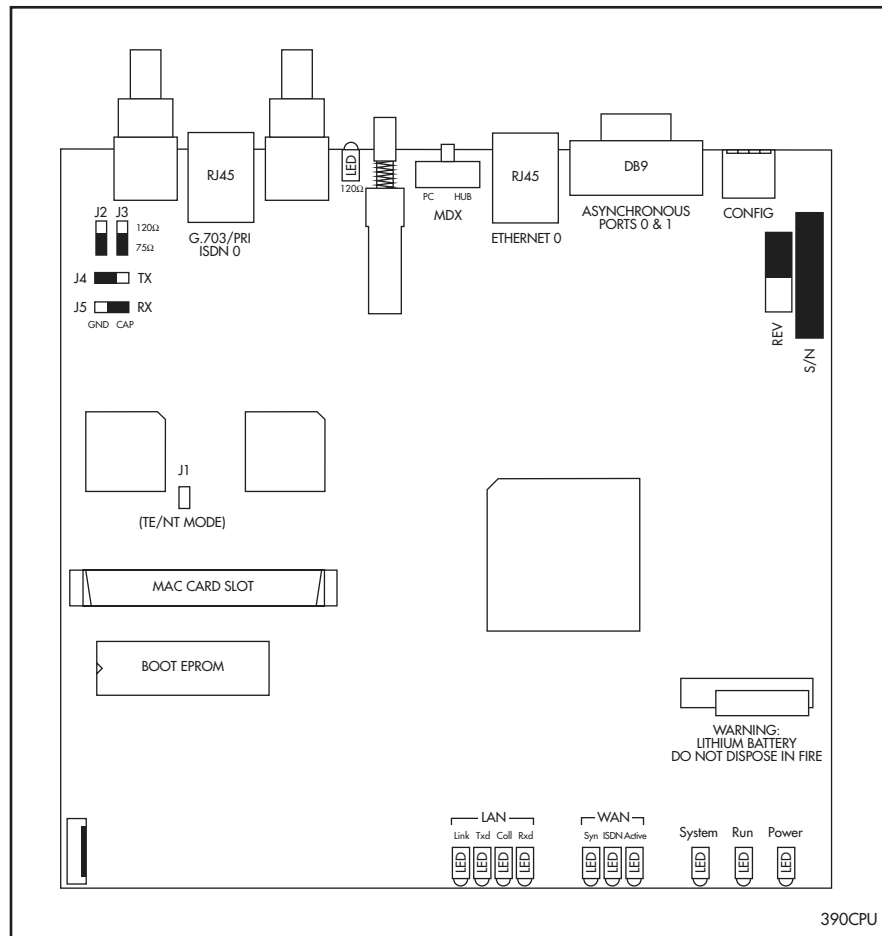

Table 13: Functions of the jumpers on the AT-AR370(U) base CPU card.

| Jumper | Function  | Factory Default          |
|--------|---|--------------------------|
| J1     | Selects NT mode (installed) or TE mode (not installed). | Not installed (TE mode). |

**Figure 14: Location of main components on the AT-AR390 and AT-AR395 base CPU cards.**



**Table 14: Functions of the jumpers on the AT-AR390, and AT-AR395 base CPU cards.**

| Jumper | Function   | Factory Default         |
|--------|--|-------------------------|
| J1     | Selects NT mode (installed) or TE mode (not installed).                  | Not installed (TE mode) |
| J2     | PRI Tx Termination (120Ω or 75Ω)   | 75Ω                     |
| J3     | PRI Rx Termination (120Ω or 75Ω)   | 75Ω                     |
| J4     | Coax Tx grounding: CAP (grounded via 100nF capacitor) or GND (grounded). | GND                     |
| J5     | Coax Rx grounding: CAP (grounded via 100nF capacitor) or GND (grounded)  | CAP                     |

## Analogue Voice Ports

The AT-AR300(S) and AT-AR310(S) have two and four analogue voice ports, respectively. The analogue voice ports provide full PABX functionality, including the ability to transfer calls from one port to another. Each analogue voice port can be individually configured to meet specific requirements, including fully programmable ringing tones.

For a complete description of the analogue voice port features and the commands available to configure the PABX services, see the Software Reference for your router.

## LAN Ports

All models in the AR300 Series, except the AT-AR330, have a single Ethernet 10BASE-T LAN port. The AT-AR330 has two Ethernet 10BASE-T LAN ports. A rear panel slide switch (labelled MDX) allows the user to configure the LAN port(s) for direct connection to either a hub or a personal computer. The same RJ-45 cable (supplied with the router) may be used in either situation.

LAN ports operate in half duplex mode and can easily be tested using a simple external loopback plug. See “*Loopback Plugs for Testing Interfaces*” on page 96 for details of how to construct a loopback plug.

## Asynchronous Ports

Asynchronous ports are wired as standard DB9 connectors, and can be connected to most PCs using a standard DB9-to-DB9 cable. An approved DB9-to-DB9 cable and DB9-to-DB25 adapter are shipped with each AR300 Series router. The connector type and maximum speed varies from model to model (Table 15 on page 33). All standard modem control lines are provided. By default, the asynchronous ports operate at 9600 bps, 8 data bits, 1 stop bit, no parity, and hardware flow control.

**Table 15: Asynchronous ports, connector types, and maximum speeds on AR300 Series routers.**

| AR300 Series Model | Asynchronous Ports | Connector Type | Maximum Speed |
|--------------------|--------------------|----------------|---------------|
| AT-AR300L(S)       | 1                  | DB9 female     | 19.2Kbps      |
| AT-AR300(S)        | 1                  | DB9 female     | 19.2Kbps      |
| AT-AR310(S)        | 1                  | DB9 female     | 19.2Kbps      |
| AT-AR320           | 2                  | DB9 male       | 115.2Kbps     |
| AT-AR330           | 2                  | DB9 male       | 115.2Kbps     |
| AT-AR350           | 2                  | DB9 male       | 115.2Kbps     |
| AT-AR370(S)        | 2                  | DB9 male       | 115.2Kbps     |
| AT-AR370(U)        | 2                  | DB9 male       | 115.2Kbps     |
| AT-AR390           | 2                  | DB9 male       | 115.2Kbps     |
| AT-AR395           | 2                  | DB9 male       | 115.2Kbps     |

## G.703/PRI ISDN Ports

The G.703/PRI ISDN port provides unchannelised 2048 kbps G.703 (model AT-AR390) or 2048 kbps Primary Rate ISDN with 30 B channels + 1 D channel (model AT-AR395). Unbalanced 75Ω coax is supported via a pair of BNC coaxial connectors. Balanced 120Ω twisted pair is also supported via an RJ-45 8-way connector. A push button switch on the rear panel is used to select the required interface type for the port, and an LED on the rear panel indicates the current selection.

The G.703/PRI ISDN port does not support “Telco supplied power” through the twisted pair interface.

Several grounding options are available for coaxial connectors. The factory default should suit all countries, but the jumper selection in Table 14 on page 32 provides flexibility. Normal practice is to ground one end only of each cable, usually the Tx cable. The other end should be left floating or connected via a 100nF capacitor.

## AR400 Series Routers

---

AR400 Series routers are high-performance broadband routers based around 10BASE-T/100BASE-TX ports. The AR410 and AR410S include a Port Interface Card (PIC) bay.

PIC bays add expansion flexibility by allowing the installation of PIC cards, which are available with ISDN (PRI E1/T1, BRI S/T, or BRI U), Ethernet, synchronous, or asynchronous ports.

There are no user-selectable jumpers or DIP switches on AR400 Series routers.

## AR410 and AR410S Routers

AR410 and AR410S routers consist of a base CPU card, enclosure, and power supply. The base CPU card supports:

- Four 10/100 Ethernet switch ports.
- One 10/100 Eth 0 port.
- One asynchronous RS-232 (ASYN 0) configuration port.
- One Port Interface Card (PIC) bay.
- One internal MAC slot (an AT-AR011V2 MAC card is factory fitted in the AR410S router).

The PIC bay can accommodate any of the following PICs:

- AT-AR020 PRI E1/T1 PIC, one Primary Rate E1/T1 port.
- AT-AR021(S) BRI-S/T PIC, one Basic Rate ISDN S/T port.
- AT-AR021(U) BRI-U PIC, one Basic Rate ISDN U port.
- AT-AR022 ETH PIC, one Ethernet LAN AUI/10BASE-T port.
- AT-AR023 SYN PIC, one Synchronous port with universal 50-way AMPLIMITE connector.
- AT-AR024 ASYN4 PIC, four Asynchronous ports with RJ-45 connectors.
- AT-AR026 4ETH PIC, four 10BASE-T/100 BASE-TX auto-negotiating ports with RJ-45 connectors.
- AT-AR027 VoIP-FXS PIC, two Foreign Exchange Subscriber (FXS) ports with RJ-11 connectors.



---

*When installed in an AR410 or AR410S router and operating in V.35 mode, synchronous PICs have full V.35 functionality, but their output voltages may not be within the voltage range set by the V.35 specification.*

---



*Synchronous PICs installed in an AR410 or AR410S cannot be fully tested with Syntester.*

The MAC slot can accommodate any one of the following MACs:

- AT-AR010 EMAC, Encryption MAC.
- AT-AR011 ECMAC, Compression/Encryption MAC
- AT-AR011 V2 ECMAC, Compression/Encryption MAC (factory fitted in the AR410S router).
- AT-AR012 CMAC, Compression MAC.



*MACs should only be installed by authorised service personnel. Unauthorised opening of the router lid may cause danger of injury from electric shock, damage to the router, and invalidation of the product warranty.*

**Figure 15: Location of main components on the AT-AR410 and AT-AR410S base CPU card.**

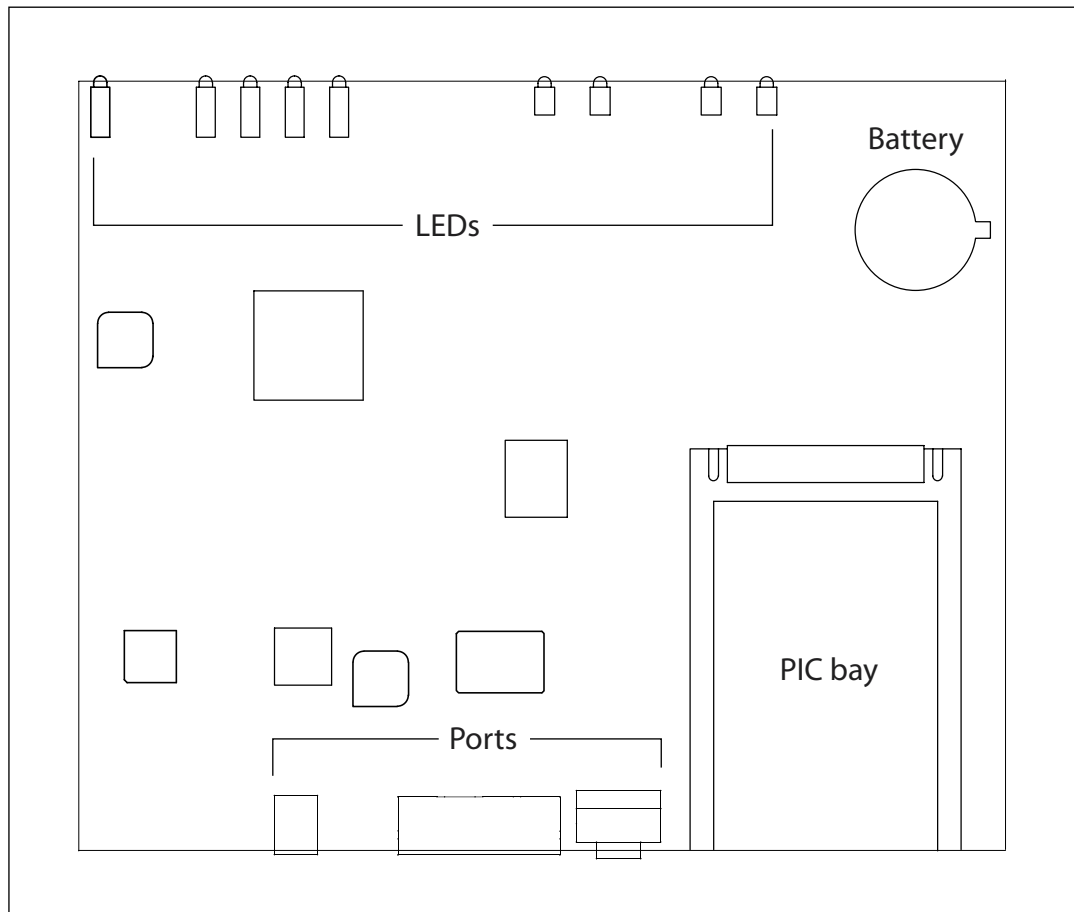

Front and rear panels of the AT-AR410 router, with a PIC installed, are shown in Figure 16 on page 36. Apart from a different model name, the AR410S is externally identical to the AR410.

Figure 16: Front and rear panels of the AT-AR410 Series router.

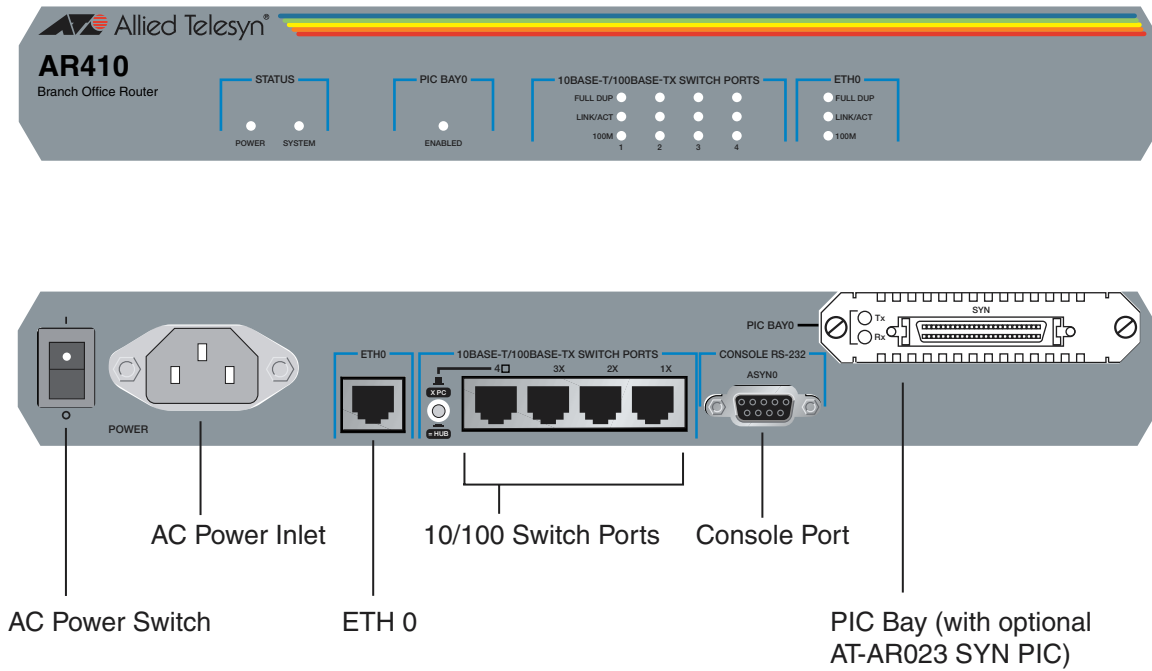

### LEDs and what they mean

Functions of AR410 and AR410S LEDs are shown in Table 16 on page 37. Additional LEDs may be present if a PIC is installed. Functions of PIC LEDs are described in the *Port Interface Card Hardware Reference*.

**Table 16: AR410 and AR410S System LEDs**

| LED                    | State    | Function   |
|------------------------|----------|--|
| Power                  | Green    | The router is receiving power and the power switch is in the ON position |
| System                 | Amber    | The Router is malfunctioning   |
|                        | Off      | Normal operation   |
| Enabled<br>(PIC Bay 0) | Green    | A PIC card is correctly installed and has been detected by the router    |
|                        | Off      | No card is installed   |
| Full                   | Green    | The corresponding port is operating at full-duplex                       |
|                        | Off      | The corresponding port is operating at half-duplex                       |
| Link/ACT               | Green    | A link has been established through the corresponding port               |
|                        | Flashing | Data is being transmitted through the corresponding port                 |
|                        | Off      | No link is present through the corresponding port                        |
| 100M                   | Green    | The corresponding port is operating at 100Mbps                           |
|                        | Off      | The corresponding port is operating at 10Mbps                            |

## The Main System

Main features of AT-AR410 and AR410S routers are:

- 66 MHz RISC processor.
- 16 MBytes of synchronous DRAM.
- 8 MBytes of flash memory (1 MByte reserved for boot code).
- 4 x 10/100 Mbps full duplex Ethernet LAN ports.
- 1 x 10/100 Mbps full duplex Ethernet WAN port.
- 1 RS-232 asynchronous serial port (maximum speed 115200 bps).
- 1 PIC bay.
- 1 MAC slot for a MAC compression/encryption card (an AT-AR011V2 MAC card is factory fitted in the AR410S router).
- Universal AC power supply.

The RS-232 asynchronous serial port (ASYN 0) can be used as a general purpose port for terminals, printers or modems. The default communications settings are:

- 9600 bps
- 8 data bits
- 1 stop bit
- no parity
- hardware flow control

## Power Supply

AT-AR410 and AT-AR410S routers have a universal AC input connector and a power switch on their rear panel. The routers require a power input of 100-240 VAC and 50–60Hz.



*Some interfaces that may be installed in the router are not transformer isolated. This means they will be referenced to the frame ground of the equipment and may be damaged if connected to an interface on another piece of equipment which is at a different ground potential.*

## AR450S Router

Each AR450S router consists of a base CPU card, enclosure, and power supply. The base CPU card supports:

- Five 10/100 LAN switch ports.
- Two 10/100 Eth ports.
- Two asynchronous RS-232 (ASYN 0 and ASYN 1) ports.

Front and rear panels of the AT-AR450S router shown in Figure 17 on page 38.

Figure 17: Front and rear panels of the AT-AR450S router.

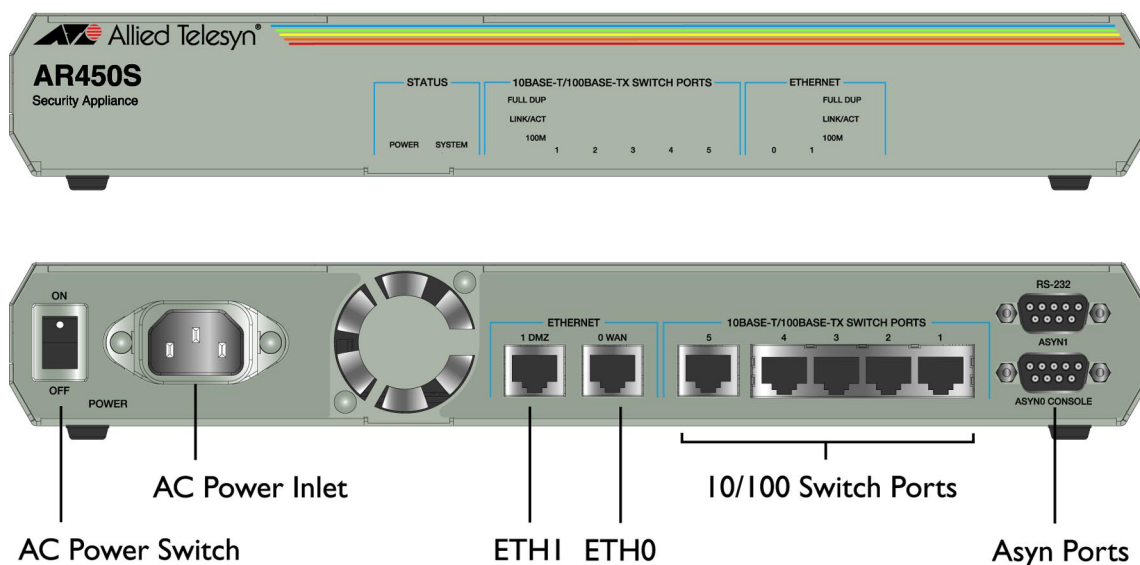

## LEDs and what they mean

Functions of AR450S LEDs are shown in Table 17 on page 39.

**Table 17: AR450 LEDs**

| LED      | State    | Function   |
|----------|----------|--|
| Power    | Green    | The router is receiving power and the power switch is in the ON position |
| System   | Amber    | The router is malfunctioning   |
|          | Flashing | The router fan has failed.   |
|          | Off      | Normal operation   |
| Full     | Green    | The corresponding port is operating at full-duplex                       |
|          | Off      | The corresponding port is operating at half-duplex                       |
| Link/ACT | Green    | A link has been established through the corresponding port               |
|          | Flashing | Data is being transmitted through the corresponding port                 |
|          | Off      | No link is present through the corresponding port                        |
| 100M     | Green    | The corresponding port is operating at 100Mbps                           |
|          | Off      | The corresponding port is operating at 10Mbps                            |

## The Main System

Main features of the AR450S router are:

- 400 MHz RISC processor.
- 64 MBytes of SDRAM, expandable to 256 MBytes.
- 16 MBytes of flash memory (1 MByte reserved for boot code).
- 5 x 10/100 Mbps full duplex, Layer 2 switched Ethernet LAN ports. All LAN ports have Auto-MDI, however if Auto-MDI is turned off, then all ports are hardwired as MDI-X. Software can also force a port to either MDI or MDI-X.
- 2 x 10/100 Mbps full-duplex Ethernet WAN ports.
- 2 x V.24 asynchronous DTE ports.
- On-board hardware encryption processor.
- 802.1Q tagged VLAN support.
- Universal AC power supply.

The RS-232 asynchronous serial ports (ASYN 0 and ASYN 1) are wired as DTE ports and can be used as general purpose ports for terminals, printers or modems. The default communications settings are:

- 9600 bps
- 8 data bits
- 1 stop bit
- no parity
- hardware flow control

**Figure 18: Location of main components on the AT-AR450S base CPU card.**

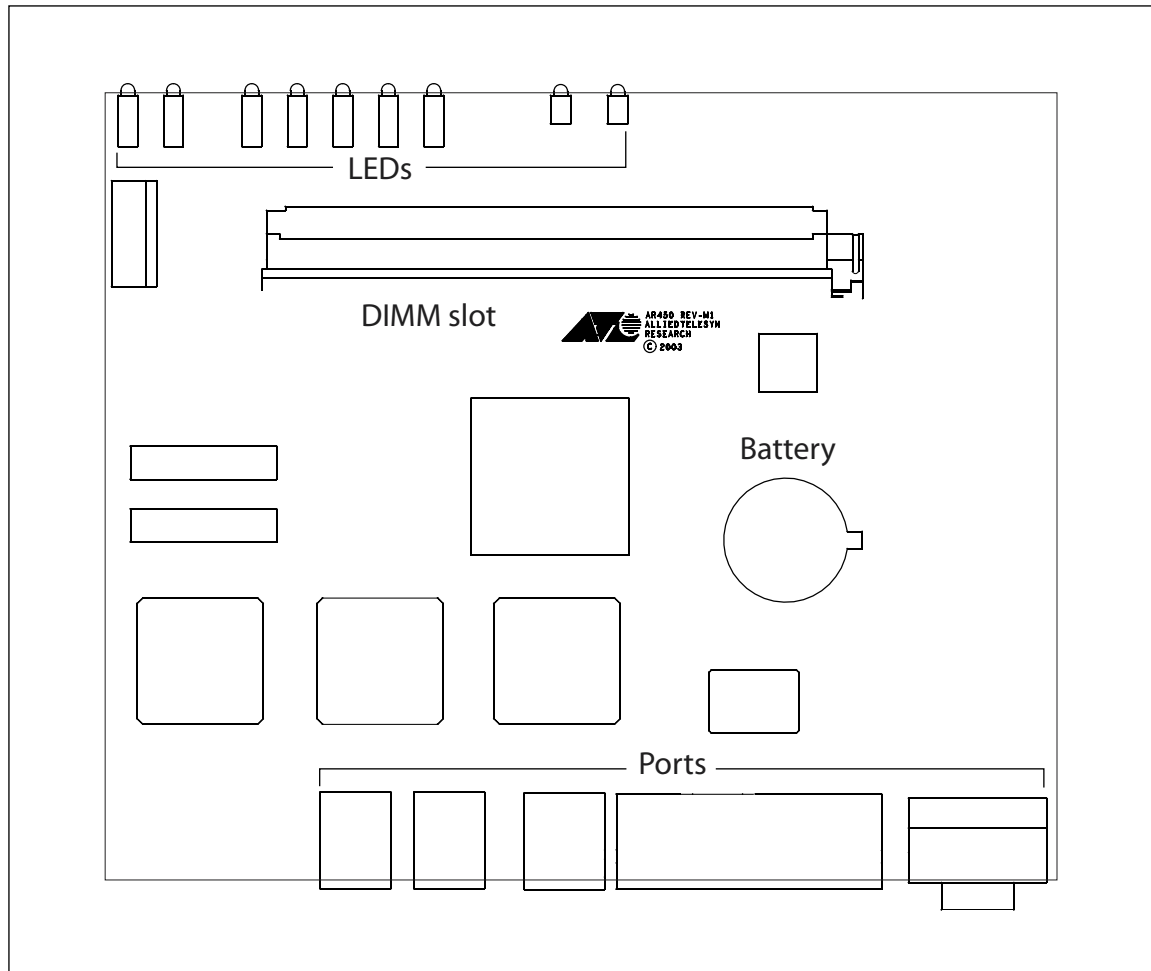

## Encryption Processor

The on-board encryption processor has the following features:

- single and triple DES, and AES symmetric encryption algorithms
- SHA-1 and MD-5 hashing support
- RSA and DH public key support.



*Some encryption options require feature licenses.*

## Power Supply

AT-AR450S routers have a universal AC input connector and a power switch on their rear panel. The routers require a power input of 100-240 VAC and 50–60Hz.



*Some interfaces that may be installed in the router are not transformer isolated. This means they will be referenced to the frame ground of the equipment and may be damaged if connected to an interface on another piece of equipment which is at a different ground potential.*

## AR700 Series Routers

All AR700 Series routers include PIC bays. PIC bays add expansion flexibility by allowing the installation of PIC cards, which are available with ISDN (PRI E1/T1, BRI S/T, or BRI U), Ethernet, synchronous, or asynchronous ports.

AR700 Series models are distinguished by the number of ports and presence or absence of an NSM bay and PAC card slot. Where present, an NSM bay allows the installation of an NSM, which may have additional ports or up to four PIC bays. A PAC slot (found on the AR725, AR740, and AR745) allows the installation of optional compression and or encryption cards, which connect to the router through a high performance PCI bus

**Table 18: Interface configurations for AR700 Series routers.**

| AR700 Series Model | Ethernet LAN Ports | Asynchronous Ports | PIC Bays (Base Unit) | NSM Bays | MAC Card Slot | PAC Card Slot |
|--------------------|--------------------|--------------------|----------------------|----------|---------------|---------------|
| AT-AR720           | 1                  | 2                  | 2                    | -        | 1             | -             |
| AT-AR725           | 2                  | 2                  | 2                    | -        | -             | 1             |
| AT-AR740           | 2                  | 2                  | 2                    | 1        | 1             | 1             |
| AT-AR745           | 2                  | 2                  | 2                    | 1        | -             | 1             |

## AR720 Router

The AT-AR720 router consists of a base CPU card, enclosure and power supply. The base CPU card supports a single 10/100 autosensing Ethernet LAN port and two asynchronous RS-232 ports.

## PIC Bays

The chassis has two *Port Interface Card* (PIC) bays, which can accommodate any combination of the following PICs:

- AT-AR020 PRI E1/T1 PIC, one Primary Rate E1/T1 port.
- AT-AR021(S) BRI-S/T PIC, one Basic Rate ISDN S/T port.
- AT-AR021(U) BRI-U PIC, one Basic Rate ISDN U port.
- AT-AR022 ETH PIC, one Ethernet LAN AUI/10BASE-T port.
- AT-AR023 SYN PIC, one Synchronous port with universal 50-way AMPLIMITE connector.
- AT-AR024 ASYN4 PIC, four Asynchronous ports with R-J45 connectors.
- AT-AR026 4ETH PIC, four 10BASE-T/100BASE-TX ports with RJ-45 connectors.
- AT-AR027 VoIP-FXS PIC, two Foreign Exchange Subscriber (FXS) ports with RJ-11 connectors.

## MAC Slot

AT-AR720 routers have a single MAC slot inside the chassis. When installed, MACs provide hardware-based encryption and or compression capability. For information on MACs, including a list of compatible MACs, see “Mini Accelerator Cards (MACs)” on page 63.



---

*MACs should only be installed by authorised service personnel. Unauthorised opening of the router lid may cause danger of injury from electric shock, damage to the router, and invalidation of the product warranty.*

---

## Front and Rear Panels

The AT-AR720 router’s front and rear panels (with a PIC installed in each PIC bay) are shown in Figure on page 42.

Table 19 on page 43 lists functions of the AT-AR720’s LEDs. Additional rear panel LEDs may be present if PICs are installed. Functions of LEDs on PICs are described in the *Port Interface Card Quick Install Guide* and *Port Interface Card Hardware Reference*.

Figure 19: Front and rear panels of the AR720 Series router.

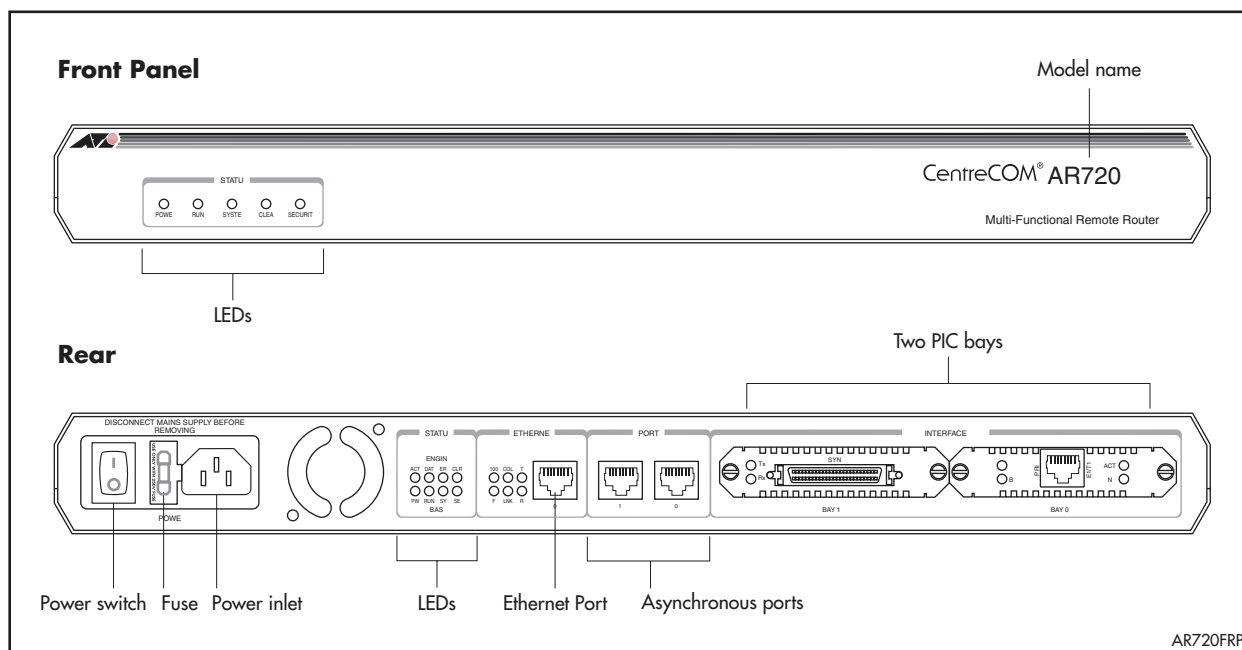

Table 19: Functions of LEDs of the AT-AR720 router.

| LED                |                   | Function  |
|--------------------|-------------------|---|
| <b>Front panel</b> | <b>Rear panel</b> |   |
|                    | <b>ETH</b>        | These LEDs give indications about the Ethernet interfaces.  |
|                    | Col               | Lit when a collision is detected on the Ethernet interface.   |
|                    | Lnk               | Lit when the Ethernet interface is connected to a device (e.g., a hub), which is generating link pulses.  |
|                    | Tx                | Lit when data is being transmitted over the Ethernet interface.   |
|                    | Rx                | Lit when data is being received on the Ethernet interface.  |
|                    | FD                | Lit when the Ethernet interface is in full duplex mode.   |
|                    | 100               | Lit when the Ethernet interface is in 100 Mbps mode.  |
|                    | <b>BASE</b>       | These LEDs indicate the state of the main router unit.  |
| Power              | PWR               | Lit when power is supplied and the router is switched on.   |
| Run                | RUN               | Lit when the internal processor is executing code. If the processor stops for any reason (a fault condition), then the LED will not be lit.   |
| System             | SYS               | This LED is not normally lit. It is used to signal various system conditions (e.g., when the processor executes the reboot sequence). Generally it signals a possible fault condition, but it is lit during a power-up or operator initiated reboot, and remains lit until a release has been loaded from flash memory. |
| Security           | SEC               | Lit when a user is logged in with SECURITY OFFICER privilege and the router is in SECURITY MODE.  |
|                    | <b>ENGINE</b>     | These LEDs give indications about a MAC (Mini Accelerator Card), which can be installed for encryption and/or compression purposes.   |
|                    | ACT               | Lit when a MAC card is installed in the MAC slot.   |
|                    | DAT               | Lit when data is transferred to or from the MAC card.   |

**Table 19: Functions of LEDs of the AT-AR720 router. (Continued)**

| LED   | Function   |
|-------|--|
| ERR   | Lit when there is an error in the data transmission to or from the MAC card.   |
| Clear | CLR<br>Lit when a secure router has enabled PPP interfaces or Frame Relay circuits that are configured to send clear text. |

## Hardware Features

Main hardware features of the AT-AR720 are:

- 50 MHz RISC processor.
- 1 MByte of EPROM.
- 16 MBytes of synchronous DRAM.
- 4 MBytes of flash memory, expandable to 8 MBytes for early models.
- 128 KBytes of battery backed SRAM.
- A high performance 10/100 Fast Ethernet LAN port.
- 2 RS-232 asynchronous serial ports.
- 2 PIC bays.
- A MAC compression/encryption card slot.

The Ethernet LAN port is an autosensing 10/100 full duplex interface. The router auto-senses which interface type is in use.

The two asynchronous serial ports can be used as general purpose ports for terminals, printers, or modems. They are effectively identical and can be independently configured. The default communications settings are:

- 9600 bps
- 8 data bits
- 1 stop bit
- No parity
- Hardware flow control

Port 0 can optionally be used for diagnostics or can automatically output the router start-up messages, by altering the internal DIP switch settings described in “*Diagnostics*” on page 113.

## AR725 Router

The AT-AR725 router consists of a base CPU card, enclosure and power supply. The base CPU card supports dual 10/100 autosensing Ethernet LAN ports and two asynchronous RS-232 ports.

### PIC Bays

The chassis has two *Port Interface Card* (PIC) bays, which can accommodate any combination of the following PICs:

- AT-AR020 PRI E1/T1 PIC, one Primary Rate E1/T1 port.
- AT-AR021(S) BRI-S/T PIC, one Basic Rate ISDN S/T port.
- AT-AR021(U) BRI-U PIC, one Basic Rate ISDN U port.
- AT-AR022 ETH PIC, one Ethernet LAN AUI/10BASE-T port.
- AT-AR023 SYN PIC, one Synchronous port with universal 50-way AMPLIMITE connector.
- AT-AR024 ASYN4 PIC, four Asynchronous ports with R-J45 connectors.
- AT-AR026 4ETH PIC, four 10BASE-T/100BASE-TX ports with RJ-45 connectors.
- AT-AR027 VoIP-FXS PIC, two Foreign Exchange Subscriber (FXS) ports with RJ-11 connectors.



---

*When used with an AR725 router, ETH PICs should be installed in the router's PIC bay 0 or PIC bay 1.*

---

### CompactFlash slot

The AT-AR725 has a CompactFlash slot on its front panel. For information on CompactFlash, including a list of compatible flash cards, see "CompactFlash" on page 70.

### PAC slot

The AT-AR725 router has a single PAC slot inside the chassis. When installed, PACs provide hardware-based encryption and or compression capability via a PCI interface. For information on PACs, including a list of compatible PACs, see "PCI Accelerator Cards (PACs)" on page 65.

### Front and Rear Panels

The AT-AR725 router's front and rear panels (with a PIC installed in each PIC bay) are shown in Figure 20 on page 46.

Table 20 on page 46 lists functions of the AT-AR725's LEDs. Additional rear panel LEDs may be present if PICs are installed. Functions of LEDs on PICs are described in the *Port Interface Card Quick Install Guide* and *Port Interface Card Hardware Reference*.

Figure 20: Front and rear panels of the AR725 Series router.

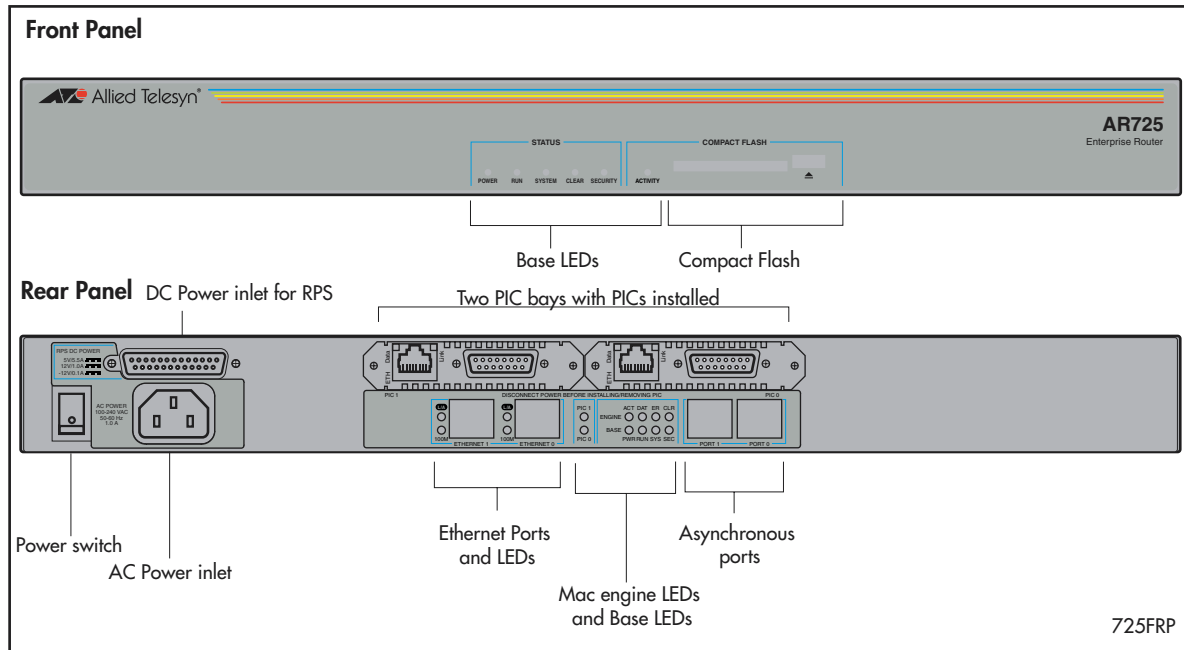

Table 20: Functions of LEDs of the AT-AR725 router.

| LED                         |                     | Function  |
|-----------------------------|---------------------|---|
| <b>Front panel</b>          | <b>Rear panel</b>   |   |
|                             | <b>ETH</b>          | These LEDs give indications about the Ethernet interfaces. There are two LEDs for each Eth port.  |
|                             | L/A (Link/Activity) | Lit green when the Ethernet interface is connected to a device (e.g., a hub), which is generating link pulses. Blinks yellow when data is being transmitted or received on the Ethernet interface.  |
|                             | 100M                | Lit when the Ethernet interface is in 100 Mbps mode.  |
|                             | PICO/PIC 1          | Lit when a PIC is inserted in either PIC bay 0 or PIC bay 1 (one LED for each PIC).   |
|                             | <b>BASE</b>         | These LEDs indicate the state of the main router unit.  |
| Power                       | PWR                 | Lit when power is supplied and the router is switched on.   |
| Run                         | RUN                 | Lit when the internal processor is executing code. If the processor stops for any reason (a fault condition), then the LED will not be lit.   |
| System                      | SYS                 | This LED is not normally lit. It is used to signal various system conditions (e.g., when the processor executes the reboot sequence). Generally it signals a possible fault condition, but it is lit during a power-up or operator initiated reboot, and remains lit until a release has been loaded from flash memory. |
| Security                    | SEC                 | Lit when a user is logged in with SECURITY OFFICER privilege and the router is in SECURITY MODE.  |
| Activity<br>(Compact Flash) |                     | Lit when the compact flash card is accessed.<br><b>Do not remove the compact flash card when the LED is lit.</b>  |
|                             | <b>ENGINE</b>       | These LEDs give indications about a MAC (Mini Accelerator Card), which can be installed for encryption and/or compression purposes.   |
|                             | ACT                 | Lit when a MAC card is installed in the MAC slot.   |
|                             | DAT                 | Lit when data is transferred to or from the MAC card.   |
|                             | ERR                 | Lit when there is an error in the data transmission to or from the MAC card.  |
| Clear                       | CLR                 | Lit when a secure router has enabled PPP interfaces or Frame Relay circuits that are configured to send clear text.   |

## Hardware Features

Main hardware features of the AT-AR725 are:

- 80 MHz RISC processor.
- 1 MByte of EPROM.
- 128 MBytes of synchronous DRAM (DIMM module).
- 16 MBytes of on-board flash memory.
- CompactFlash slot.
- 128 KBytes of battery backed SRAM.
- 2 high performance 10/100 Fast Ethernet LAN ports.
- 2 RS-232 asynchronous serial ports.
- 2 PIC bays.
- A PAC compression/encryption card slot.
- Connector for a Redundant Power Supply (RPS).

The Ethernet LAN ports are autosensing 10/100 full duplex interfaces. The router auto-senses which interface type is in use.

The two asynchronous serial ports can be used as general purpose ports for terminals, printers, or modems. They are effectively identical and can be independently configured. The default communications settings are:

- 9600 bps
- 8 data bits
- 1 stop bit
- No parity
- Hardware flow control

## AR740 Router

The AT-AR740 router consists of a base CPU card, enclosure, and power supply. The base CPU card supports two 10/100 autosensing Ethernet LAN ports and two asynchronous RS-232 ports.

### PIC bays and NSM bay

The AT-AR740 chassis has two PIC bays. A further four PIC bays can be added if an AT-AR040 NSM is installed in the NSM bay.

The NSM bay allows one NSM to be installed in the chassis. NSMs either have fixed ports (e.g., AT-AR041 and AT-AR042 BRI S/T NSMs) or PIC bays (e.g., the AT-AR040 4 PIC NSM). For detailed information on NSMs, see the *Network Service Module Hardware Reference*.

The PIC bays and the 4-PIC NSM can accommodate combinations of the following PICs (with a maximum of two E1/T1/PRI cards):

- AT-AR020 PRI E1/T1 PIC, one Primary Rate E1/T1 port.
- AT-AR021(S) BRI-S/T PIC, one Basic Rate ISDN S/T port.
- AT-AR021(U) BRI-U PIC, one Basic Rate ISDN U port.

- AT-AR023 SYN PIC, one Synchronous port with universal 50-way AMPLIMITE connector.
- AT-AR024 ASYN4 PIC, four Asynchronous ports with RJ-45 connectors.
- AT-AR027 VoIP-FXS PIC, two Foreign Exchange Subscriber (FXS) ports with RJ-11 connectors.



---

*AT-AR022 ETH PICs and AT-AR026 4ETH PICs are not recommended for use in NSM PIC bays, as performance of these interfaces is likely to be reduced and packet loss may occur. When used with an AR740 router, ETH PICs should be installed in the router's PIC bay 0 or PIC bay 1.*

---

## MAC slot

AT-AR740 routers have a single MAC slot inside the chassis. When installed, MACs provide hardware-based encryption and or compression capability. For information on MACs, including a list of compatible MACs, see "Mini Accelerator Cards (MACs)" on page 63.



---

*MACs should only be installed by authorised service personnel. Unauthorised opening of the router lid may cause danger of injury from electric shock, damage to the router, and invalidation of the product warranty.*

---

## PAC slot

AT-AR740 routers have a single PAC slot inside the chassis. When installed, PACs provide hardware-based encryption and or compression capability via a PCI interface. For information on PACs, including a list of compatible PACs, see "PCI Accelerator Cards (PACs)" on page 65.



---

*PACs should only be installed by authorised service personnel. Unauthorised opening of the router lid may cause danger of injury from electric shock, damage to the router, and invalidation of the product warranty.*

---

## Front and Rear Panels

Front and rear panels of the AT-AR740 router with a PIC installed in each PIC bay, and an AT-AR040 4-PIC NSM installed in the NSM bay, are shown in Figure 21 on page 49.

Figure 21: Front and rear panels of the AT-AR740 Series router.

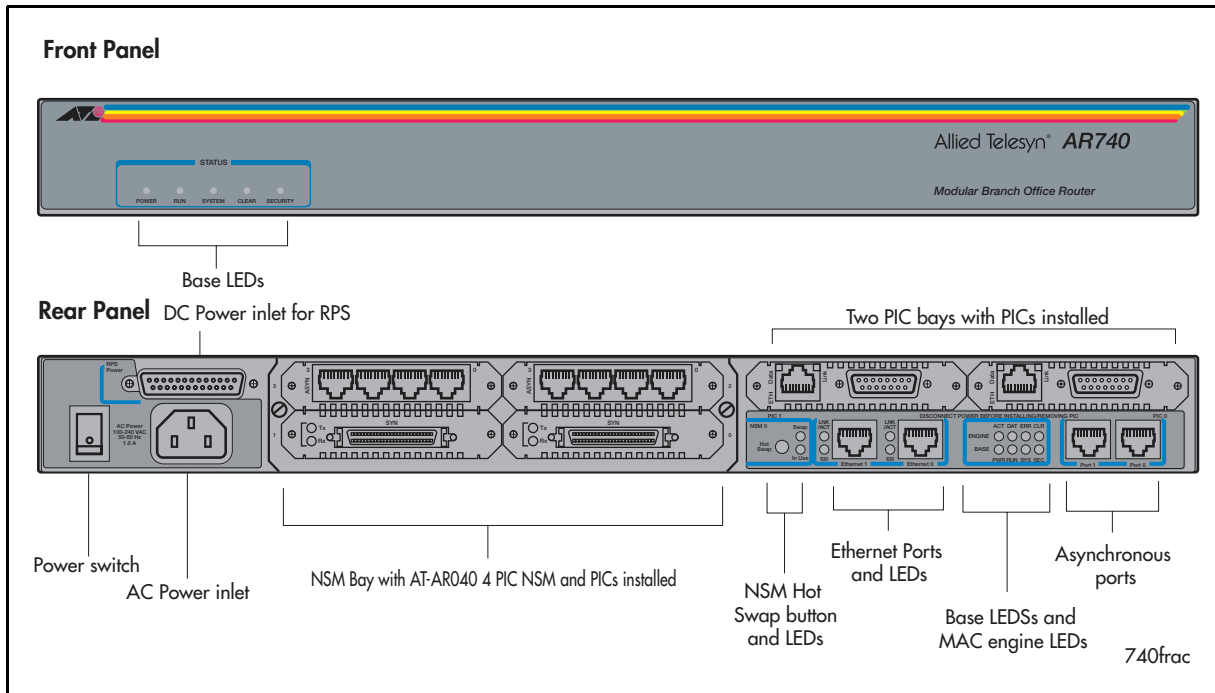

### LEDs and what they mean

Functions of the AR740’s LEDs are shown in Table 21 on page 49. Additional rear panel LEDs may be present if a PIC or NSM is installed. Functions of PIC and NSM LEDs are described in their respective Hardware References.

Table 21: Functions of AT-AR740 router LEDs.

| LED                | Function   |
|--------------------|--|
| <b>Front panel</b> | <b>Rear panel</b>  |
|                    | <b>ETH</b>   |
|                    | These LEDs give indications about the Ethernet interfaces.   |
|                    | LNK/ACT  |
|                    | Lit green when the Ethernet interface is connected to a device (e.g., a hub) which is generating link pulses. Lit yellow indicates transmission or reception activity. |
|                    | 100M   |
|                    | Lit when the Ethernet interface is in 100 Mbps mode.   |
|                    | <b>BASE</b>  |
|                    | These LEDs indicate the state of the main router unit.   |
| Power              | PWR  |
|                    | Lit when power is supplied and the router is switched on.  |
| Run                | RUN  |
|                    | Lit when the internal processor is executing code. If the processor stops for any reason (a fault condition), then the LED will not be lit.                            |
| System             | SYS  |
|                    | Lit when the router or management software is malfunctioning. Flashes to indicate fan, PSU, and RPS faults.  |
|                    | 1 Flash: A router fan has failed.  |
|                    | 2 Flashes: If an RPS is connected and RPS monitoring is enabled, an RPS fan has failed.  |
|                    | 3 Flashes: If an RPS is connected, the router’s PSU (Power Supply Unit) has failed.  |
|                    | 4 Flashes: If RPS monitoring is enabled, the RPS PSU has failed.   |
|                    | 5 Flashes: If RPS monitoring is enabled, an RPS is not connected or is not operational   |
| Security           | SEC  |
|                    | Lit when a user is logged in with SECURITY OFFICER privilege and the router is in SECURITY MODE.   |
|                    | <b>ENGINE</b>  |
|                    | These LEDs give indications about a MAC card, which can be installed for encryption and/or compression purposes.   |

**Table 21: Functions of AT-AR740 router LEDs. (Continued)**

| LED    | Function   |
|--------|--|
| ACT    | Lit when a MAC card is installed in the MAC slot.  |
| DAT    | Lit when data is transferred to or from the MAC card.  |
| ERR    | Lit when there is an error in the data transmission to or from the MAC card.   |
| Clear  | CLR<br>Lit when a secure router has enabled PPP interfaces or Frame Relay circuits that are configured to send clear text.   |
|        | <b>NSM</b><br>These LEDs give indications about an NSM installed in the router.  |
| Swap   | Lit when the NSM and its PICs are powered down and can be hot swapped. Only lights if the Hot Swap button has been pressed and the software release supports hot swapping <sup>1</sup> . |
| In Use | Lit when an NSM is correctly installed. If the software release supports hot swapping, it indicates that the NSM and its PICs are powered up and may not be swapped.                     |

1. Hot swapping is supported by Software Release 2.3.1 or later. AT-AR021 (S) BRI-S/T, AT-AR021 (U) BRI-U, AT-AR022 ETH, AT-AR023 SYN, and AT-AR026 4ETH PICs can be hot swapped.

The AT-AR740 router automatically monitors its own power supply and fan, and has the option of a redundant power supply. If a redundant power supply (RPS) is attached, the AT-AR740 software can detect the presence of the RPS and the state of its output voltages and fan. RPS monitoring, turned off by default, can be turned on or off using the command:

```
SET SYSTEM RPSMONITOR={ON | OFF}
```

The SHOW SYSTEM command displays the state of the main power supply and fan, and whether or not the RPS is being monitored. If RPS monitoring is enabled, it also shows whether an RPS is connected, and the state of its output voltage and fan.

When a fault occurs in the main power supply or fan, system LEDs on the AT-AR740's front and back panels are flashed in a pattern that identifies the fault (Table 21 on page 49). If RPS monitoring is enabled, the system LEDs also flash to indicate failures in the RPS connection, power supply or fan. Multiple faults are indicated by cycling through each error code.

## Hardware Features

Main hardware features of the AT-AR740 are:

- 80 MHz RISC processor.
- 1 MByte of EPROM.
- 16 MBytes of synchronous DRAM.
- 6 MBytes of on-board flash memory.
- 128 KBytes of battery backed SRAM.
- 2 x 10/100 Mbps autosensing Ethernet LAN ports.
- 2 RS-232 asynchronous serial ports.
- 2 PIC bays.
- 1 hot swappable *Network Service Module* (NSM) bay.
- 1 MAC slot for a MAC compression/encryption card.

- 1 PAC slot for PAC compression and/or encryption cards.
- Connector for a Redundant Power Supply (RPS).
- -48V DC power supply option.

Figure 22 on page 51 shows the location of the main components on the AT-AR740 base unit. There are no user-selectable jumpers or DIP switches.

**Figure 22: Location of main components on the AT-AR740 base CPU card.**

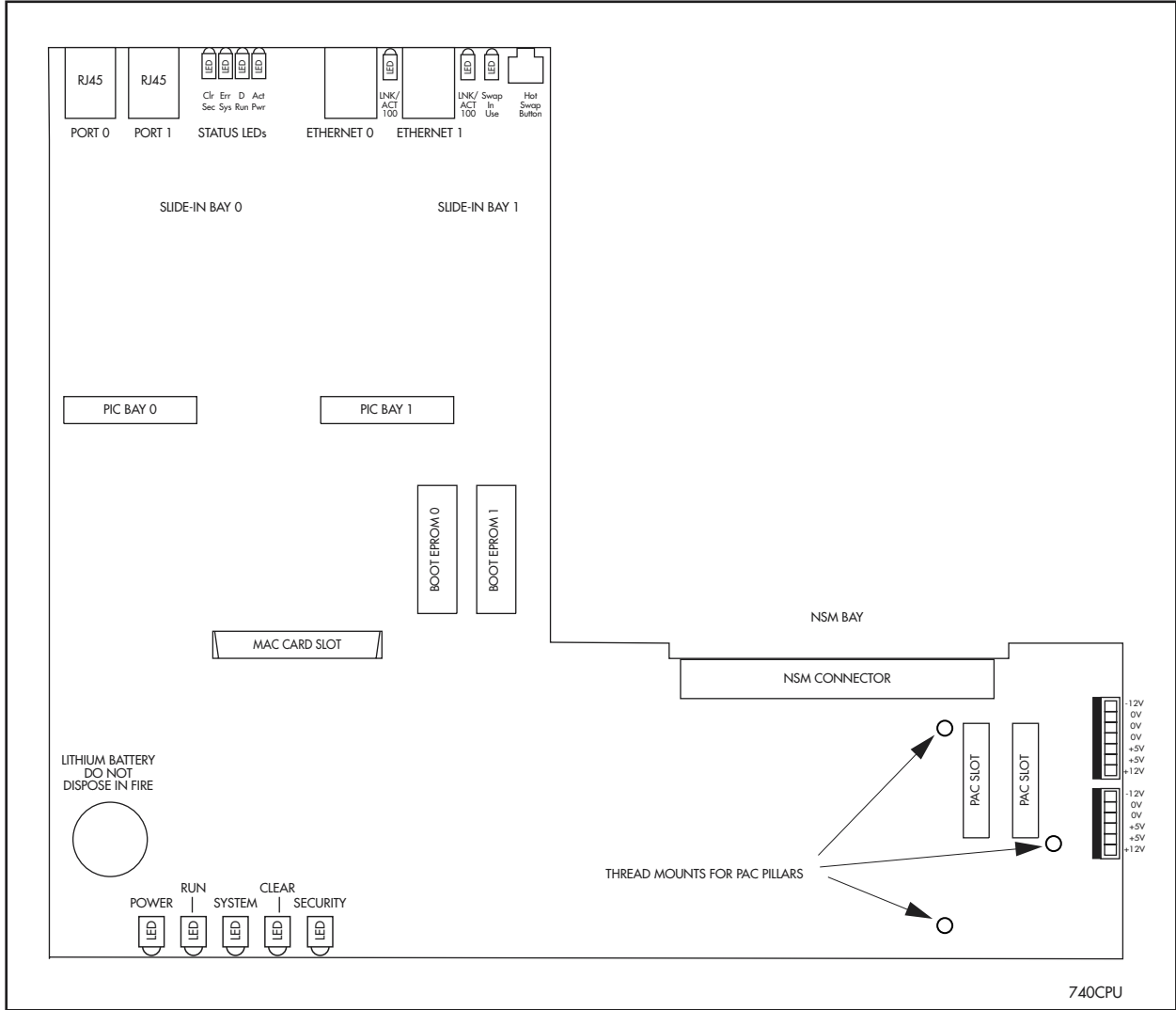

The Ethernet LAN ports are autosensing 10/100 full duplex interfaces.

The two asynchronous serial ports can be used as general purpose ports for terminals, printers or modems. They are effectively identical and can be independently configured. The default communications settings are:

- 9600 bps
- 8 data bits
- 1 stop bit
- no parity
- hardware flow control.

## Power Supply

The AT-AR740 is available in two power supply configurations: a universal AC model and a 48V DC model. The AC model includes an inlet for the AT-RPS 740 (Redundant Power Supply). The AT-RPS 740 can be purchased separately, and each unit supports up to two AT-AR740 routers.

### AT-AR740 AC

AC models of the AT-AR740 have a universal AC input connector and a power switch on their rear panels. A DB25 connector for an optional external *Redundant Power Supply (RPS)*, such as the AT-RPS 740, is also located on the rear panel.

Pin outs for the DB25 RPS connector, and cable specifications for RPS supply cables, can be found in “Redundant Power Supply (RPS)” on page 45.

Software Release 2.0 or higher includes monitoring functions for the PSU and fan in both the AT-AR740 and the RPS. See “LEDs and what they mean” on page 40, for more information.

### AT-AR740-80 DC

The AT-AR740-80, designed for use by telecommunication carrier sites, supports connection to a 48V DC power supply (in the range 39-59V DC). The DC model does not support an RPS connection, and does not support monitoring of the main PSU or fan.



---

*Instructions outlining how to connect an AT-AR740-80 to a DC power supply can be found in the AR700 Series Router Quick Install Guide. You should read these instructions and your router's Safety Information before attempting to connect the router to a DC power supply*

---



---

*Some interfaces that may be installed in the router are not transformer isolated. This means they will be referenced to the frame ground of the equipment and may be damaged if connected to an interface on another piece of equipment which is at a different ground potential.*

---

## Redundant Power Supply (RPS)

AC models of the AT-AR740 can be used in conjunction with the AT-RPS 740. Each AT-RPS 740 can provide power supply and mains circuit redundancy for up to two AT-AR740s. For more information on the AT-RPS 740, see “AT-RPS 740” on page 59.

For connection to an AT-RPS 740, the AT-AR740 Router has a female DB25 connector on its rear panel (Figure 23 on page 53). Pin outs for the connector are listed in Table 22 on page 53.

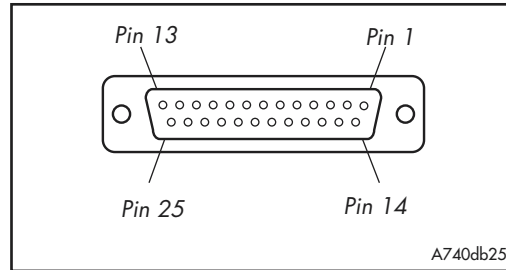
**Figure 23: DB25 female connector pinout for an RPS on the AT-AR740 rear panel****Table 22: DB25 RPS power connector pin out on the AT-AR740.**

| Pin        | Function         | Direction |
|------------|------------------|-----------|
| 1, 25      | Keying           | -         |
| 2, 14      | +12V             | input     |
| 3-5, 15-17 | +5V              | input     |
| 6-8, 18-20 | 0V               | input     |
| 9          | -12V             | input     |
| 10         | VCC              | output    |
| 11         | Main PSU error   | output    |
| 12         | Main fan error   | output    |
| 13         | RPS disconnected | input     |
| 21         | Sense 0V         | output    |
| 22         | Sense +5V        | output    |
| 23         | RPS PSU error    | output    |
| 24         | RPS fan error    | input     |

## AR745 Router

The AT-AR745 router consists of a base CPU card, enclosure, and power supply. The base CPU card supports two 10/100 autosensing Ethernet LAN ports and two asynchronous RS-232 ports.

### PIC bays and NSM bay

The AT-AR745 chassis has two PIC bays. A further four PIC bays can be added if an AT-AR040 NSM is installed in the NSM bay.

The NSM bay allows one NSM to be installed in the chassis. NSMs either have fixed ports (e.g., AT-AR041 and AT-AR042 BRI S/T NSMs) or PIC bays (e.g., the AT-AR040 4 PIC NSM). For detailed information on NSMs, see the *Network Service Module Hardware Reference*.

The PIC bays and the 4-PIC NSM can accommodate combinations of the following PICs (with a maximum of two E1/T1/PRI cards):

- AT-AR020 PRI E1/T1 PIC, one Primary Rate E1/T1 port.
- AT-AR021(S) BRI-S/T PIC, one Basic Rate ISDN S/T port.
- AT-AR021(U) BRI-U PIC, one Basic Rate ISDN U port.
- AT-AR023 SYN PIC, one Synchronous port with universal 50-way AMPLIMITE connector.

- AT-AR024 ASYN4 PIC, four Asynchronous ports with RJ-45 connectors.
- AT-AR027 VoIP-FXS PIC, two Foreign Exchange Subscriber (FXS) ports with RJ-11 connectors.



*AT-AR022 ETH PICs and AT-AR026 4ETH PICs are not recommended for use in NSM PIC bays, as performance of these interfaces is likely to be reduced and packet loss may occur. When used with an AR745 router, ETH PICs should be installed in the router's PIC bay 0 or PIC bay 1.*

## PAC Slot

AT-AR745 routers have a single PAC slot inside the chassis. When installed, PACs provide hardware-based encryption and or compression capability via a PCI interface. For information on PACs, including a list of compatible PACs, see "PCI Accelerator Cards (PACs)" on page 65.



*PACs should only be installed by authorised service personnel. Unauthorised opening of the router lid may cause danger of injury from electric shock, damage to the router, and invalidation of the product warranty.*

## Front and Rear Panels

Front and rear panels of the AT-AR745 router with a PIC installed in each PIC bay, and an AT-AR040 4-PIC NSM installed in the NSM bay, are shown in Figure 24 on page 54.

Figure 24: Front and rear panels of the AT-AR745 Series router.

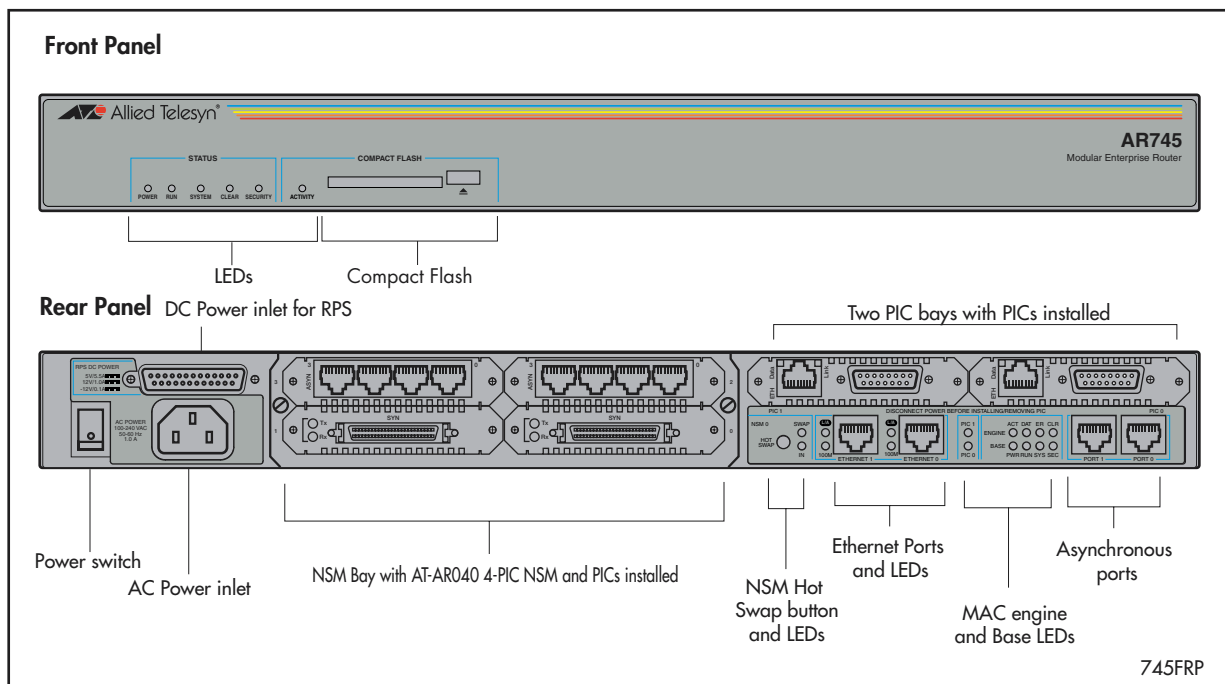

## LEDs and what they mean

Functions of the AR745's LEDs are shown in Table 23 on page 55. Additional rear panel LEDs may be present if a PIC or NSM is installed. Functions of PIC and NSM LEDs are described in their respective Hardware References.

**Table 23: Functions of AT-AR745 router LEDs.**

| LED                         |                   | Function   |
|-----------------------------|-------------------|--|
| <b>Front panel</b>          | <b>Rear panel</b> |  |
|                             | <b>ETH</b>        | These LEDs give indications about the Ethernet interfaces.   |
|                             | LNK/ACT           | Lit green when the Ethernet interface is connected to a device (e.g., a hub) which is generating link pulses. Lit yellow indicates transmission or reception activity.   |
|                             | 100M              | Lit when the Ethernet interface is in 100 Mbps mode.   |
|                             | PIC0/PIC1         | Lit when a PIC is inserted in either PIC bay 0 or PIC bay 1 (one LED for each PIC).  |
|                             | <b>BASE</b>       | These LEDs indicate the state of the main router unit.   |
| Power                       | PWR               | Lit when power is supplied and the router is switched on.  |
| Run                         | RUN               | Lit when the internal processor is executing code. If the processor stops for any reason (a fault condition), then the LED will not be lit.  |
| System                      | SYS               | Lit when the router or management software is malfunctioning. Flashes to indicate fan, PSU, and RPS faults.<br>1 Flash: A router fan has failed.<br>2 Flashes: If an RPS is connected and RPS monitoring is enabled, an RPS fan has failed.<br>3 Flashes: If an RPS is connected, the router's PSU (Power Supply Unit) has failed.<br>4 Flashes: If RPS monitoring is enabled, the RPS PSU has failed.<br>5 Flashes: If RPS monitoring is enabled, an RPS is not connected or is not operational |
| Security                    | SEC               | Lit when a user is logged in with SECURITY OFFICER privilege and the router is in SECURITY MODE.   |
| Activity<br>(Compact Flash) |                   | Lit when the compact flash card is accessed.<br><b>Do not remove the compact flash card when the LED is lit.</b>   |
|                             | <b>ENGINE</b>     | These LEDs give indications about a MAC card, which can be installed for encryption and/or compression purposes.   |
|                             | ACT               | Lit when a MAC card is installed in the MAC slot.  |
|                             | DAT               | Lit when data is transferred to or from the MAC card.  |
|                             | ERR               | Lit when there is an error in the data transmission to or from the MAC card.   |
| Clear                       | CLR               | Lit when a secure router has enabled PPP interfaces or Frame Relay circuits that are configured to send clear text.  |
|                             | <b>NSM</b>        | These LEDs give indications about an NSM installed in the router.  |
|                             | Swap              | Lit when the NSM and its PICs are powered down and can be hot swapped. Only lights if the Hot Swap button has been pressed and the software release supports hot swapping <sup>1</sup> .   |
|                             | In Use            | Lit when an NSM is correctly installed. If the software release supports hot swapping, it indicates that the NSM and its PICs are powered up and may not be swapped.   |

1. Hot swapping is supported by Software Release 2.3.1 or later. AT-AR021 (S) BRI-S/T, AT-AR021 (U) BRI-U, AT-AR022 ETH, AT-AR023 SYN, and AT-AR026 4ETH PICs can be hot swapped.

The AT-AR745 router automatically monitors its own power supply and fan, and has the option of a redundant power supply. If a redundant power supply

(RPS) is attached, the AT-AR745 software can detect the presence of the RPS and the state of its output voltages and fan. RPS monitoring, turned off by default, can be turned on or off using the command:

```
SET SYSTEM RPSMONITOR={ON|OFF}
```

The SHOW SYSTEM command displays the state of the main power supply and fan, and whether or not the RPS is being monitored. If RPS monitoring is enabled, it also shows whether an RPS is connected, and the state of its output voltage and fan.

When a fault occurs in the main power supply or fan, system LEDs on the AT-AR745's front and back panels are flashed in a pattern that identifies the fault (Table 23 on page 55). If RPS monitoring is enabled, the system LEDs also flash to indicate failures in the RPS connection, power supply or fan. Multiple faults are indicated by cycling through each error code.

## Hardware Features

Main hardware features of the AT-AR745 are:

- 80 MHz RISC processor.
- 1 MByte of EPROM.
- 128 MBytes of synchronous DRAM (DIMM module).
- 16 MBytes of on-board flash memory.
- CompactFlash slot.
- 128 KBytes of battery backed SRAM.
- 2 x 10/100 Mbps autosensing Ethernet LAN ports.
- 2 RS-232 asynchronous serial ports.
- 2 PIC bays.
- 1 hot swappable *Network Service Module* (NSM) bay.
- 1 PAC slot for PAC compression and/or encryption cards.
- Connector for a Redundant Power Supply (RPS).
- -48V DC power supply option.

Figure 25 on page 57 shows the location of the main components on the AT-AR745 base CPU card. There are no user-selectable jumpers or DIP switches.

Figure 25: Location of main components on the AT-AR745 base CPU card.

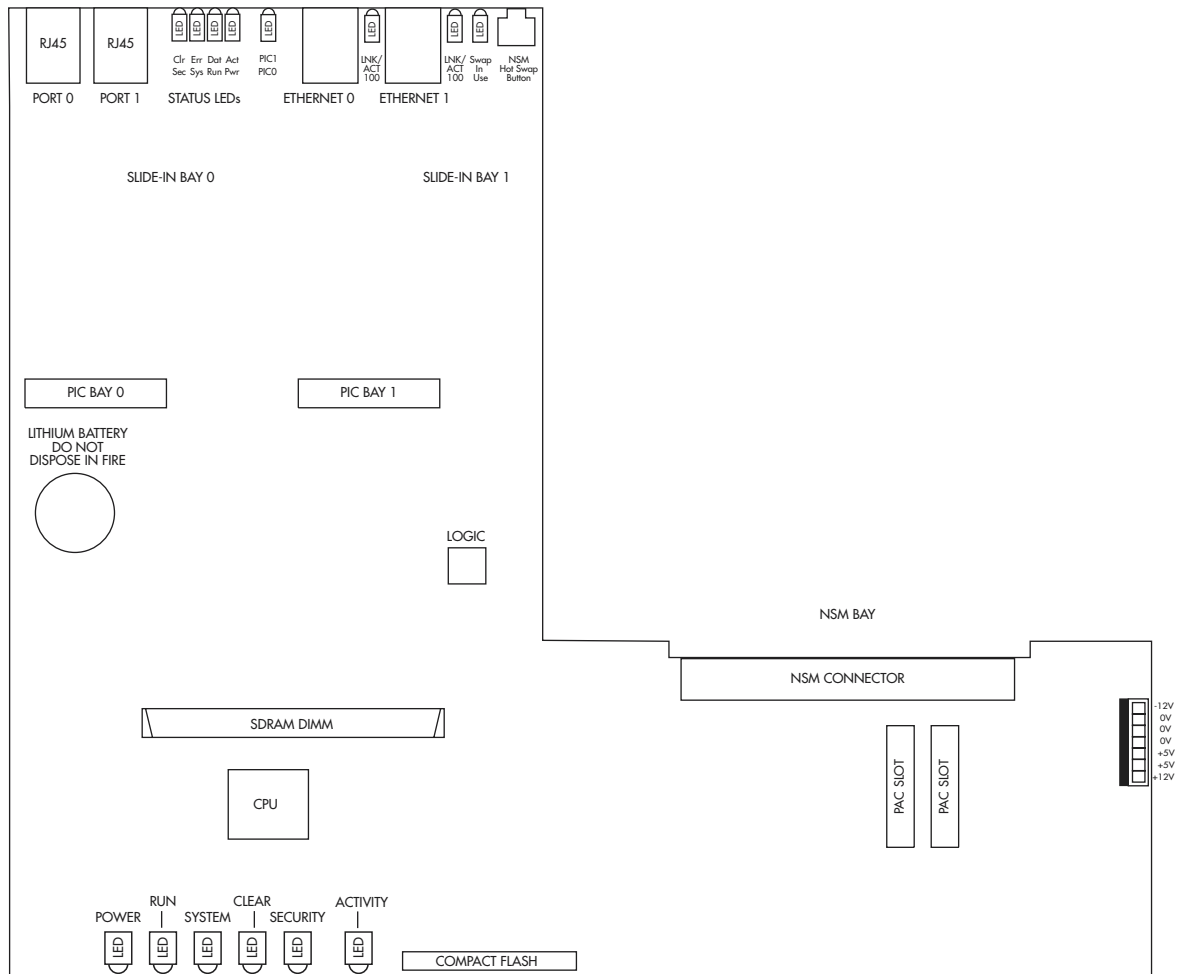

745CPU

The Ethernet LAN ports are autosensing 10/100 full duplex interfaces.

The two asynchronous serial ports can be used as general purpose ports for terminals, printers or modems. They are effectively identical and can be independently configured. The default communications settings are:

- 9600 bps
- 8 data bits
- 1 stop bit
- no parity
- hardware flow control.

## Power Supply

The AT-AR745 is available in two power supply configurations: a universal AC model and a 48V DC model. The AC model includes an inlet for the AT-RPS 740 (Redundant Power Supply). The AT-RPS 740 can be purchased separately, and each unit supports up to two AT-AR745 routers. The AT-RPS 740 is compatible with the AR725, AR740, and AR745 routers.

## AT-AR745 AC

AC models of the AT-AR745 have a universal AC input connector and a power switch on their rear panels. A DB25 connector for an optional external *Redundant Power Supply (RPS)*, such as the AT-RPS 740, is also located on the rear panel.

Pin outs for the DB25 RPS connector, and cable specifications for RPS supply cables, can be found in “Redundant Power Supply (RPS)” on page 52.

Software Release 2.0 or higher includes monitoring functions for the PSU and fan in both the AT-AR745 and the RPS. See “LEDs and what they mean” on page 55 for more information.

## AT-AR745-80 DC

The AT-AR745-80, designed for use by telecommunication carrier sites, supports connection to a 48V DC power supply (in the range 39-59V DC). The DC model does not support an RPS connection, and does not support monitoring of the main PSU or fan.



*Instructions outlining how to connect an AT-AR745-80 to a DC power supply can be found in the AR700 Series Router Quick Install Guide. You should read these instructions and your router’s Safety Information before attempting to connect the router to a DC power supply*



*Some interfaces that may be installed in the router are not transformer isolated. This means they will be referenced to the frame ground of the equipment and may be damaged if connected to an interface on another piece of equipment which is at a different ground potential.*

## Redundant Power Supply (RPS)

AC models of the AT-AR745 can be used in conjunction with the AT-RPS 740. Each AT-RPS 740 can provide power supply and mains circuit redundancy for up to two AT-AR740s, AT-AR725s, or AT-AR745s. For more information on the AT-RPS 740, see “AT-RPS 740” on page 59.

For connection to an AT-RPS 740, the AT-AR745 router has a female DB25 connector on its rear panel (Figure 26 on page 58). Pin outs for the connector are listed in Table 24 on page 59.

**Figure 26: DB25 female connector pinout for an RPS on the AT-AR745 rear panel**

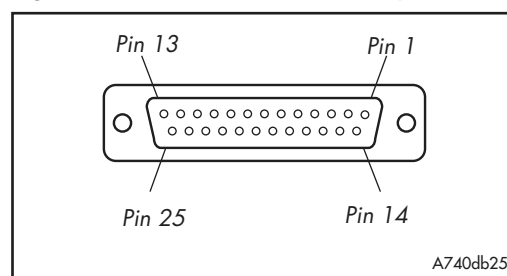

**Table 24: DB25 RPS power connector pin out on the AT-AR745.**

| Pin        | Function         | Direction |
|------------|------------------|-----------|
| 1, 25      | Keying           | -         |
| 2, 14      | +12V             | input     |
| 3-5, 15-17 | +5V              | input     |
| 6-8, 18-20 | 0V               | input     |
| 9          | -12V             | input     |
| 10         | VCC              | output    |
| 11         | Main PSU error   | output    |
| 12         | Main fan error   | output    |
| 13         | RPS disconnected | input     |
| 21         | Sense 0V         | output    |
| 22         | Sense +5V        | output    |
| 23         | RPS PSU error    | output    |
| 24         | RPS fan error    | input     |

## AT-RPS 740

Each AT-RPS 740 can provide power supply and mains circuit redundancy for up to two AT-AR740 AC routers. The AT-RPS 740 cannot be used with DC versions of the router.

Installation instructions for the AT-RPS 740 can be found in the *AR740 Router Quick Start Guide*. This guide is packed with each AT-RPS 740, or can be downloaded from [www.alliedtelesyn.co.nz/documentation/documentation.html](http://www.alliedtelesyn.co.nz/documentation/documentation.html).

Figure 27 on page 60 shows the AT-RPS 740 front and rear panels.

Figure 27: Front and rear panels of the AT-RPS 740.

## Front panel



## Rear panel

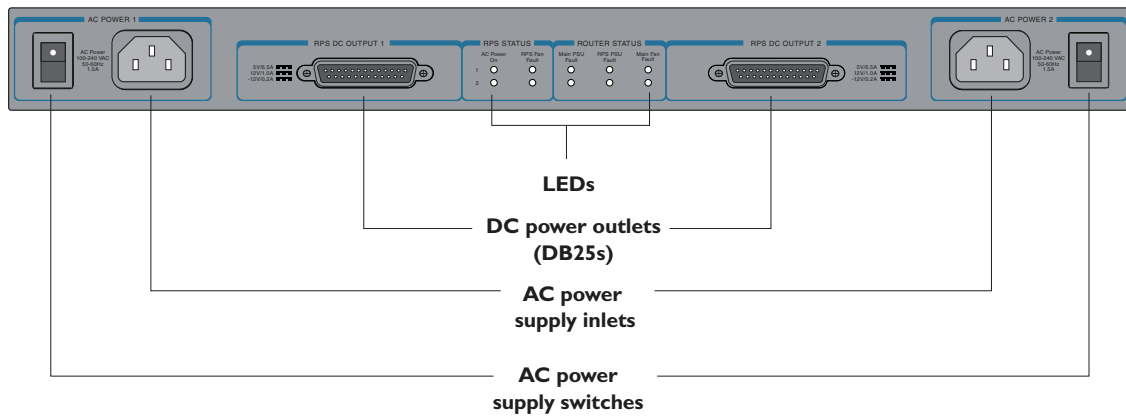

## DC supply cables

Two DC supply cables are packed with each AT-RPS 740. If making your own cable, use a cable that conforms to UL2464, and has at least twenty-three 24AWG cores. The cables will need a DB25 male connector on both ends and should be wired in a straight-through configuration. Pin outs for the connectors are listed in Table 25 on page 61.

Figure 28: DB25 male pinout on the AT-RPS 740

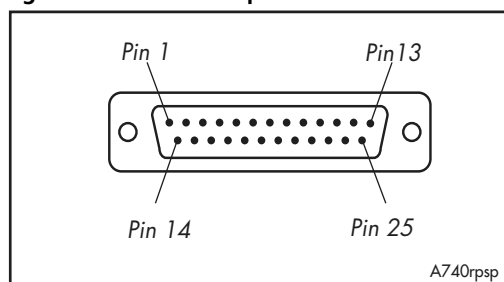

**Table 25: DB25 RPS power connector pin out on AT-RPS 740.**

| Pin        | Function       | Direction |
|------------|----------------|-----------|
| 1, 25      | Keying         | -         |
| 2, 14      | +12V           | output    |
| 3-5, 15-17 | +5V            | output    |
| 6-8, 18-20 | 0V             | output    |
| 9          | -12V           | output    |
| 10         | VCC            | input     |
| 11         | Main PSU error | input     |
| 12         | Main fan error | input     |
| 13         | 0V             | output    |
| 21         | Sense 0V       | input     |
| 22         | Sense +5V      | input     |
| 23         | RPS PSU error  | input     |
| 24         | RPS fan error  | output    |

## Specifications

### Dimensions

- Height = 44 mm (plus 5.5 mm if the rubber feet are used)
- Width = 440 mm (excluding rack-mounting brackets)
- Depth = 315 mm
- Weight = 3.75 kg

### Mounting System

- 1.5U rack mounting

### Environmental Conditions

- Operating temperature range: 0 to 40° C (32 to 104° F)
- Storage temperature range: -25 to 70° C (-13 to 158° F)
- Relative humidity range: 5 to 95% non-condensing

### Regulatory Standards

- EMC: CISPR22 class A, FCC class A, and VCCI class I
- Immunity testing to EN50082 levels 2 (ESD), 3 (susceptibility), 4 (fast transients), 5 (power surge), and 6 (RF immunity)
- Safety: UL1950, CSA22.2, EN60950 and CE

## LEDs

- AC power supply
- RPS fan fault
- Router PSU fault
- RPS PSU fault
- Main (router) fan fault

## AC Power Supply

- Universal 110/240 VAC 50/60 Hz input

## DC Output

- 5V/6.5A
- 12V/1.0A
- -12V/0.2A

## LEDs

LEDs on the rear panel indicate the RPS's operational status.

**Table 26: AT-RPS 740 LEDs.**

| LED            | State | Function   |
|----------------|-------|--|
| Power          | Green | The RPS unit is receiving AC power and the voltage is within an acceptable range.  |
| RPS Fan Fault  | Amber | The RPS is switched OFF.<br>Mains power to the RPS has failed.<br>An RPS fan has failed.   |
|                | Off   | Normal operation.  |
| Main PSU Fault | Amber | The corresponding router is switched OFF or its PSU has failed.<br>Mains power to the router has failed.<br>The DC cable between the router and RPS is not connected.<br>The RPS is supplying power to the router. |
|                | Off   | Normal operation.  |
| RPS PSU Fault  | Amber | The RPS is switched OFF or its PSU has failed.<br>Mains power to the RPS has failed.<br>The DC cable between the corresponding router and RPS is not connected.  |
|                | Off   | Normal operation.  |
| Main Fan Fault | Amber | The DC cable between the corresponding router and RPS is not connected.<br>A main router fan has failed.   |
|                | Off   | Normal operation.  |

## Mini Accelerator Cards (MACs)

Mini Accelerator Cards (MACs) provide additional processing features or performance, but do not add extra physical interfaces to the router. A MAC can be installed in the dedicated MAC slot (labelled *Coprocessor Interface*) on all AR300 Series, AR400 Series, and AR720/AR740 routers.



**MACs should only be installed by authorised service personnel. Unauthorised opening of the router lid may cause danger of injury from electric shock, damage to the router, and invalidation of the product warranty.**

Three MACs are available:

- AT-AR010 EMAC, Encryption MAC.
- AT-AR011 V2 ECMAC, Encryption/Compression MAC.
- AT-AR012 CMAC, Compression MAC.

See “*Restricted Procedures*” on page 100 for more information on the MAC installation procedure.

### How MACs work

MACs provide AR routers with high performance hardware-based encryption and/or compression services. MACs have a DMA slave processor, which operates independently of the base system. This processor is responsible for the transfer of data between the base system and the MAC, and the control of local high speed encryption and compression data processing devices.

This architecture allows data encoding to be performed off-line without involving the base router processor in the process, thereby maximising MAC performance while at the same time minimising impact on the router.

The MAC is a single card. Figure 29 on page 63 shows the layout of the board for the AT-AR011 V2 ECMAC.

**Figure 29: Location of main components on the AT-AR011 V2 ECMAC.**

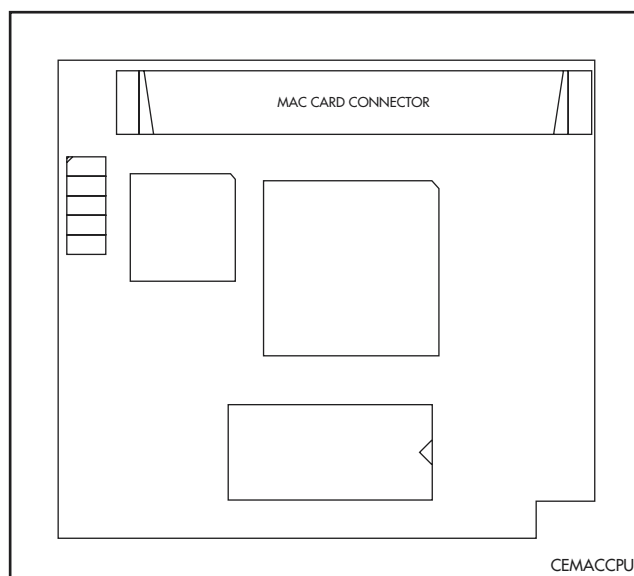

## Compression

MAC-based compression has the following features:

- Local 32-bit processor for high speed control and data transfer.
- Dedicated high performance 32-bit compression hardware.
- High compression ratio Lempel-Ziv algorithm in hardware.
- 2 MBytes of history memory.
- Support for up to 127 compression channels.

Compression and decompression operations are performed by a 32-bit data compression coprocessor specifically designed for high-performance Lempel-Ziv compression applications. The 2 MBytes of history memory allows up to 127 individual data links to use compression concurrently, enabling MACs to provide compression for complicated network architectures. Figure 30 on page 64 shows typical compression ratios achieved by a MAC for a representative set of file types.

**Figure 30: Typical hardware compression ratios by file type.**

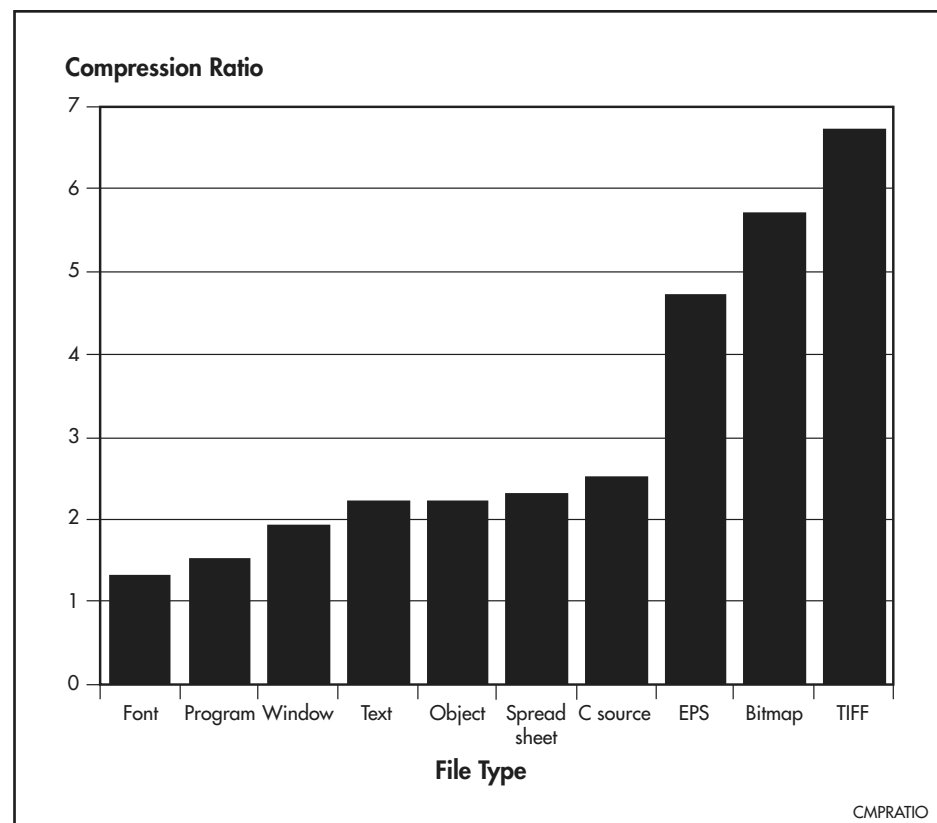

## Encryption

MAC-based encryption has the following features:

- Local 32-bit processor for high speed control and data transfer.
- Dedicated high performance 32-bit Data Encryption Standard (DES) hardware.
- Optional key access control.
- Support for up to 127 encryption channels.

MAC DES encryption is based on a fast 32-bit device that complies with FIPS PUB 46, ISO DEA-1 and ANSI X3.92 standards.

## Dual Mode

Throughput of an encrypted link can be dramatically increased by using data compression. To support this, ECMACs support both encryption and compression to provide a dual mode which allows combined compression and encryption operations. So that the compression phase will have the best opportunity at finding non-random data, compression occurs before encryption, in the order:

compression → encryption → // → decryption → decompression

Adding compression to an encrypted link increases line throughput. Once compression has been carried out there is less data requiring encryption, passing back to the base system, and transferring across the network, so less base system bus and network link bandwidth is required for a given amount of data. This results in the dual operation being very effective where encryption is required.

## PCI Accelerator Cards (PACs)

---

PCI Accelerator Cards (PACs) provide additional processing features or performance, but do not add extra physical interfaces to the router. A PAC can be installed in the dedicated PAC slot on AT-AR725, AT-AR740, and AT-AR745 routers.

Where a MAC and PAC are installed in the same router, only the PAC will function.



***PACs should only be installed by authorised service personnel. Unauthorised opening of the router's lid may cause danger of injury from electric shock, damage to the router, and invalidation of the product warranty.***

---

Two PACs are available:

- AT-AR060 EPAC, Encryption PAC.
- AT-AR061 ECPAC, Encryption/Compression PAC.

See “*Restricted Procedures*” on page 100 for more information on the PAC installation procedure.

## How PACs work

PACs provide AR725, AR740, and AR745 routers with high performance hardware-based encryption and/or compression services. PACs have a DMA slave processor, which operates independently of the base system. This processor is responsible for the transfer of data between the base system and the PAC, and the control of local high speed encryption and compression data processing devices.

This architecture allows data encoding to be performed off-line without involving the base router processor, thereby maximising PAC performance while at the same time minimising impact on the router.

The PAC is a single card. Figure 31 on page 66 shows the layout of the board for an AT-AR061 ECPAC.

**Figure 31: Location of main components on the AT-AR061 ECPAC card.**

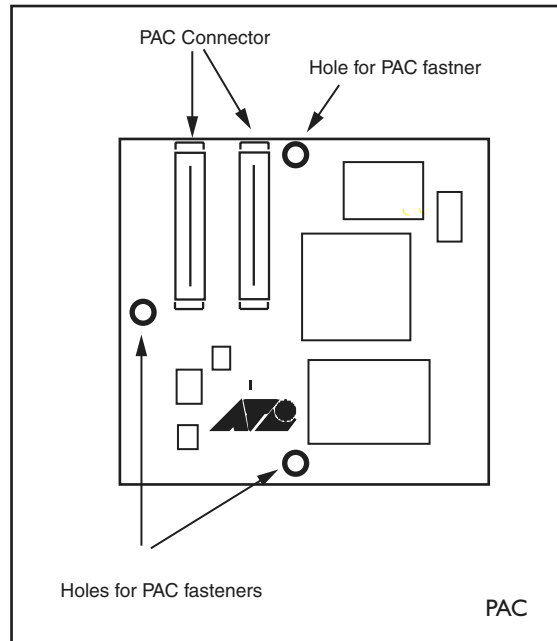

## Compression

PAC-based compression has the following features:

- Local 32-bit processor for high speed control and data transfer.
- Dedicated high performance 32-bit compression hardware.
- High compression ratio Lempel-Ziv algorithm in hardware.
- 2 MBytes of history memory.
- Support for up to 127 compression channels.

Compression and decompression operations are performed by a 32-bit data compression coprocessor specifically designed for high-performance Lempel-Ziv compression applications. The 2 MBytes of history memory allows up to 127 individual data links to use compression concurrently, enabling PACs to provide compression for complicated network architectures. Figure 32 on page 67 shows typical compression ratios achieved by a PAC for a representative set of file types.

Figure 32: Typical hardware compression ratios by file type.

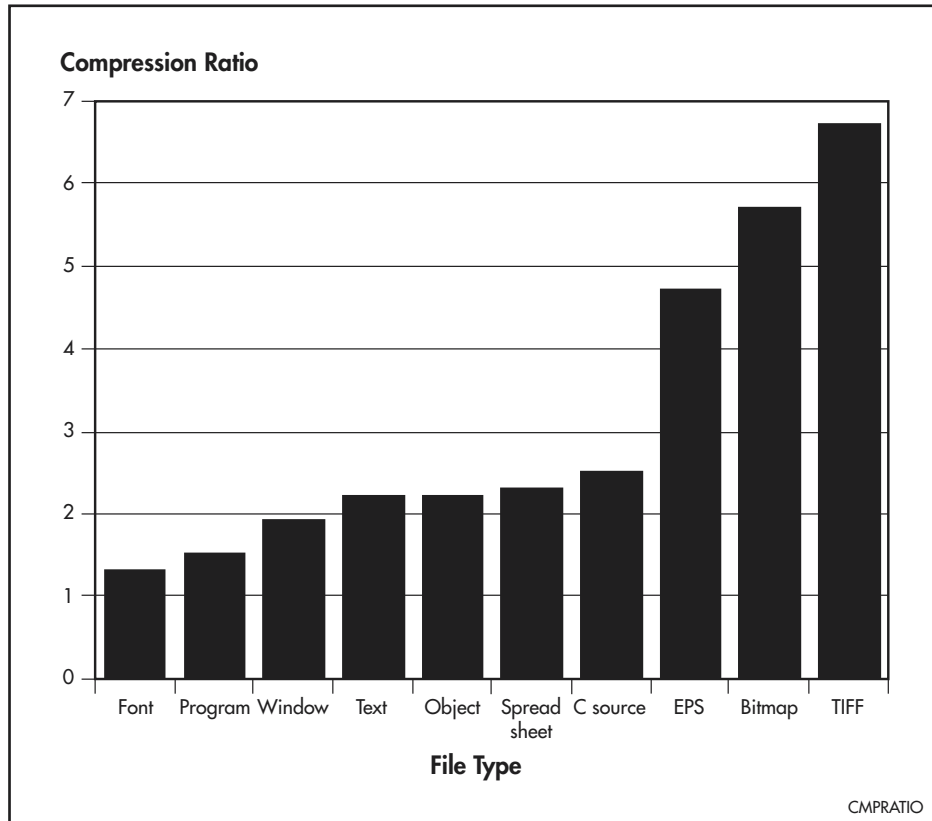

## Encryption

PAC-based encryption has the following features:

- Local 32-bit processor for high speed control and data transfer.
- Dedicated high performance 32-bit Data Encryption Standard – DES and Triple DES (3DES) – hardware.

PAC DES and triple DES encryption are based on a fast 32-bit device that complies with FIPS PUB 46, ISO DEA-1 and ANSI X3.92 standards.

## Dual Mode

Throughput of an encrypted link can be dramatically increased by using data compression. To support this, ECPACs support both encryption and compression, providing a dual mode that allows combined compression and encryption operations. So that the compression phase will have the best opportunity at finding non-random data, compression occurs before encryption, in the order:

compression → encryption → // → decryption → decompression

Adding compression to an encrypted link increases line throughput. Once compression has been carried out there is less data requiring encryption, passing back to the base system, and transferring across the network, so less base system bus and network link bandwidth is required for a given amount of data. This results in the dual operation being very effective where encryption is required.

## Flash Memory

---

Flash memory is a nonvolatile reprogrammable memory storage device for router software releases, allowing upgrades to be remotely loaded from any WAN or LAN port. Flash memory is also used to store other types of data such as patches, logs and configurations.

There are two types of flash — onboard flash (flash connected directly to the router's PCB and available on all routers), and CompactFlash (flash provided by removable compact flash cards). AR725 and AR745 routers have a slot for compact flash cards.

### Onboard flash

AR Series routers have the following quantities of onboard flash memory:

- AR300 routers, 2 MB of fixed, non-expandable flash
- AR720 routers, 4 MB of fixed, non-expandable flash (early models can be upgraded to 8 MB of flash)
- AR740 routers, 6 MB of fixed, non-expandable flash
- AR725 and AR745 routers, 16 MB of fixed flash (and a slot for compact flash cards)

An AR router with 2 MB of flash memory can have at least one software release upgrade stored at any time, while 4 MB of flash memory allows up to 3 releases to be stored.

### Testing Onboard Flash Memory

There are several ways to check that onboard flash memory is installed and operating correctly. First, check that the router has recognised the flash memory, using the command:

```
SHOW SYSTEM
```

to display system information (Figure 33 on page 69). The second part of the display shows the types and sizes of memory installed in the router. If the flash memory size is lower than expected, then the router's boot process has not correctly detected or recognised the flash memory's presence. If recognition fails, contact your authorised Allied Telesyn distributor or reseller.

If the flash is recognised, enter the command:

```
SHOW FLASH PHYSICAL
```

to display flash memory size, device type and location. A typical display is shown in Figure 34 on page 69.

Lastly, the Flash File System (FFS) can be checked to ensure that it has successfully formatted the flash, using the command:

```
SHOW FILE
```

If flash memory has been used in the past then it may already be formatted and contain files. With erased or new flash memory that has been correctly formatted, an 80 byte hidden system file is present. A typical display for an FFS is shown in Figure 35 on page 70.

**Figure 33: Example output from the SHOW SYSTEM command for the AT-AR720 router.**

```

Router System Status                               Time 17:10:06 Date 25-Sep-1999.
Board      ID  Bay Board Name                               Rev   Serial number
-----
Base       62      AR720                               M1-0  6845218
IC Module  40   0  AR022 PIC Eth                               M2-0  6844595
IC Module  38   1  AR023 PIC Sync                             M1-1  6844715
MAC        67      AR012 CMAC                             M2-0  33636409
-----
Memory -   DRAM : 16384 kB   FLASH :  4192 kB
-----
SysDescription
CentreCOM AR720 version 1.8.1-00 08-Sep-1999
SysContact
Mr Squiggles
SysLocation
Laboratory, First Floor, Head Office Building
SysName
LAB
SysUpTime
250074 ( 00:41:40 )
Software Version: 1.8.1-00 08-Sep-1999
Release Version : 1.8.1-00 08-Sep-1999
Patch Installed : NONE
Territory      : europe
Help File      : help.hlp

Boot configuration file: load.cfg (exists)
Current configuration: load.cfg
Security Mode   : Disabled

Patch files
Name           Device      Size      Version
-----
52772-02.paz   flash      94856     7.7.2-2
-----

```

**Figure 34: Example output from the SHOW FLASH PHYSICAL command for an AT-AR720.**

```

total size ..... 4 MBytes
device type ..... 28F008
devices ..... 8
location ..... SIMM stick and built in
programming power ..... off
block erase time ..... 1600 milliseconds
total erase blocks .... 64
erase block size ..... 128 kBytes
erase bit state ..... 1
page buffers ..... 0
size of page buffer ... 0 bytes

```

Figure 35: Example output from the SHOW FILE command for an AT-AR720.

| dev        | creator | name    | type          | size      | file date & time     | address  | check |
|------------|---------|---------|---------------|-----------|----------------------|----------|-------|
| flash      | inst    | release | lic           | 64        | 15-Oct-1999 10:23:08 | 02723B20 | -     |
| flash      | load    | 52772   | pat           | 300236    | 15-Oct-1999 10:11:47 | 02559AC4 | -     |
| flash      | load    | 52-181  | rez           | 1575696   | 15-Oct-1999 10:21:48 | 025A2FD0 | -     |
| flash      | load    | 52-772  | rez           | 1415624   | 15-Oct-1999 10:09:17 | 0240005C | -     |
| -----      |         |         |               |           |                      |          |       |
| flash use: |         |         |               |           |                      |          |       |
|            | files   | .....   | 3291968 bytes | (4 files) |                      |          |       |
|            | garbage | ...     | 96 bytes      |           |                      |          |       |
|            | free    | .....   | 902516 bytes  |           |                      |          |       |
|            | total   | .....   | 4194304 bytes |           |                      |          |       |
| -----      |         |         |               |           |                      |          |       |

A complete test of flash memory may also be carried out using the router's built-in diagnostics. See "Diagnostics" on page 113 for more information.



*The diagnostics flash memory test will erase the entire flash contents.*

## CompactFlash

AR725 and AR745 routers have a CompactFlash slot on their front panel. Compact flash cards increase the flash memory available for file storage.

CompactFlash files can be manipulated using the command line interface. Any type of data, including releases, patches, GUIs and configurations can be stored on compact flash cards. However, release, patch, and GUI files cannot be run directly from CompactFlash. These files must be loaded into either NVS or onboard Flash.



*Data contained on compact flash cards can be read with any compliant reader. Do not keep sensitive data, for example keys, on compact flash cards.*

CompactFlash functionality is supported by software Release 2.5.1 and later.

Three compact flash cards have been approved for use with AR725 and AR745 routers:

- AT-CF032A-00 COMPFLASH 32MB
- AT-CF064A-00 COMPFLASH 64MB
- AT-CF128A-00 COMPFLASH 128MB

For the latest list of approved compact flash cards, visit [www.alliedtelesyn.co.nz/products/options.html](http://www.alliedtelesyn.co.nz/products/options.html).

## Installing and removing a compact flash card

Compact flash cards can be inserted into the CompactFlash slot at any time. CLI messages are displayed when a card is inserted or removed. It takes approximately two seconds for an inserted card to be initialised. Messages notify the user when a card has been inserted:

```
Info (1106257): Compact flash card inserted.
```

and when the card is ready for use:

```
Info (1106268): Compact flash card initialisation successful.
```

A message notifies the user if the compact flash card is not compatible with the router:

```
Info (3106300): Compact flash card initialisation  
unsuccessful.
```

When CompactFlash is in use, the CompactFlash Activity LED on the front panel of the router is green.



---

*Do not remove the compact flash card when it is being written to (that is, when the CompactFlash Activity LED is lit). Doing so will corrupt data on the file being written.*

---

## Testing CompactFlash

To display information about the basic state of a compact flash card, including card size, file count and serial number, insert the card and enter the command:

```
SHOW CFLASH
```

To display cluster ranges on a card, insert the card and enter:

```
SHOW CFLASH TEST
```

Figure 36 on page 71 shows a sample output.

**Figure 36: Output from the SHOW CFLASH TEST command, when no test is running.**

```
Clusters available for testing  
Ranges:  
    [42645--61944]  
Number of free clusters = 19300  
Number of ranges       = 1  
Number of used clusters = 42645
```

To test a card, insert the card and enter:

```
ENABLE CFLASH TEST START=startnumber END=endnumber
```

where *startnumber* and *endnumber* are positive integers within a cluster range. The *endnumber* must be higher than the *startnumber*. Cluster ranges are displayed in the output of the SHOW CFLASH TEST command (Figure 36 on page 71).

The test software will read the file allocation table and display a list of free sectors. Sectors can be tested as single sectors or as a range. The test will consist of a write/read/verify cycle.

To stop the test, use the command:

```
DISABLE CFLASH TEST
```

To display the testing process while a test is in process, enter:

```
SHOW CFLASH TEST
```

Figure 37 on page 72 shows a sample output.

**Figure 37: Output from the SHOW CFLASH TEST command, when a test is running.**

```
Test Progress
  Starting cluster           = 700
  Ending cluster            = 1700
  Current cluster           = 1185

  Passed clusters number    = 485
  Passed sectors number    = 1940

  Failed clusters number    = 0
  Failed sectors number    = 0
  Used Clusters encountered = 0

  Duration..... 4417 ms
```

If used when testing is not active, the previous command displays blank cluster ranges on a compact flash card (Figure 36 on page 71).

Error messages are displayed when a file write fails. Failure could be due to the card being removed or an error in the card.

## Interfaces

Where applicable, all routers in the AR router family share common interface types. For example, the pinout of the synchronous interface on the AT-AR350 is the same as those on the AT-AR023 SYN PIC. The general description of each interface type is given in this section, therefore, applies to all AR router models and PICs.

### Asynchronous Interfaces

Asynchronous interfaces use DB9 female connectors, DB9 male connectors, or RJ-45 connectors, depending on the model or PIC (Table 27 on page 73). Pinouts match those used for most building wiring schemes (Table 28 on page 73, Table 29 on page 73, Table 30 on page 74).

**Table 27: Asynchronous interface connectors by model.**

| Router Model/Option  | Connector  | Pinouts             |
|--|------------|---------------------|
| AT-AR300L(S)<br>AT-AR300(S)<br>AT-AR310(S)<br>AT-AR410<br>AT-AR410S                    | DB9 female | Table 28 on page 73 |
| AT-AR320<br>AT-AR330<br>AT-AR350<br>AT-AR370(S)<br>AT-AR370(U)<br>AT-AR390<br>AT-AR395 | DB9 male   | Table 29 on page 73 |
| AT-AR024 ASYN4 PIC   | RJ-45      | Table 30 on page 74 |

**Table 28: Pinout of the DB9 female connectors on asynchronous interfaces (pins are numbered from left to right).**

| Pin | Function             | Signal Direction  |
|-----|----------------------|---|
| 1   | <i>Not connected</i> |   |
| 2   | TXD                  | Output from router  |
| 3   | RXD                  | Input to router   |
| 4   | DCD                  | Input to router   |
| 5   | GND                  |   |
| 6   | DTR                  | Output from router  |
| 7   | CTS                  | Input to router   |
| 8   | RTS                  | Output from router  |
| 9   | RING                 | Input to router (only available on expansion card interfaces) |

**Table 29: Pinout of the DB9 male connectors on asynchronous interfaces (pins are numbered from left to right).**

| Pin | Function             | Signal Direction   |
|-----|----------------------|--------------------|
| 1   | DCD                  | Input to router    |
| 2   | RXD                  | Input to router    |
| 3   | TXD                  | Output from router |
| 4   | DTR                  | Output from router |
| 5   | GND                  |                    |
| 6   | <i>Not connected</i> |                    |
| 7   | RTS                  | Output from router |
| 8   | CTS                  | Input to router    |
| 9   | <i>Not connected</i> |                    |

**Table 30: Pinout of the RJ-45 connectors on asynchronous interfaces (pins are numbered from left to right).**

| Pin | Function | Signal Direction  |
|-----|----------|---|
| 1   | RING     | Input to router (only available on expansion card interfaces) |
| 2   | DCD      | Input to router   |
| 3   | DTR      | Output from router  |
| 4   | GND      |   |
| 5   | RXD      | Input to router   |
| 6   | TXD      | Output from router  |
| 7   | CTS      | Input to router   |
| 8   | RTS      | Output from router  |

Asynchronous interfaces follow the RS-232 standard. A range of speeds is selectable using the SET PORT command from the *Interfaces* chapter of your router's Software Reference.

Not all signals need to be connected. In particular, both DCD and CTS are not required unless the interface has been specifically set up to use them. See the *Terminal Server* chapter of your router's Software Reference for more details. A typical terminal connection will only require RXD, TXD and GND, but refer to the equipment manual for the connected device for more specific data.



*If LPD-based printer ports are required, then the router may expect to 'see' the DTR signal from the printer connected to the DCD pin of the router. This is used to detect both the fact that the printer is 'online' and that it is 'powered-on'. This prevents print jobs from being sent to a disconnected printer and lost. See the Printer Server chapter of your router's Software Reference for more details.*

## Synchronous Interfaces

Synchronous interfaces use an AMPLIMITE 50-way connector wired as a universal connector for RS-232/V.28, V.35 and X.21 interface standards in both DTE and DCE modes. A transition cable is required to convert the AMPLIMITE to the correct physical interface for the standard required (e.g., DB15 for X.21). The transition cable can be ordered from your supplier, or you can construct your own cable.

Transition cables do more than simply change the physical connector. The router hardware reads the cable type from the AMPLIMITE plug and enables or disables the internal driver electronics as required. To function correctly, the cables must be identical to the cables described in "Cables And Loopback Plugs" on page 80.



*DCE cable types reverse the direction of data lines as well as clock lines. This cable is intended to be used when the router supplies the clock for the attached device. This is commonly used when the router is connected to the synchronous interface of another router or a host, without using an intermediate modem or NTU (Network Terminating Unit). Therefore, the DCE cable must only be connected to a router interface which is set to generate the clock. See the Interfaces chapter of your router's Software Reference for more information.*

Transition cables can be changed at any time. It is not necessary to power-down the router.

When an RS-232 DCE transition cable is connected to a synchronous interface configured to generate clocks, the maximum clock speed is 38400 bps. When an X.21 DCE or V.35 DCE transition cable is connected to a synchronous interface configured to generate clocks, the maximum clock speed is 2 Mbps.

## Modems and NTUs

Modems and NTUs are used to transfer digital information over wide area Telecom links. Strictly speaking, a modem is an analog device, while an NTU is digital device.

Modems can be either asynchronous or synchronous. The distinction is that synchronous modems provide a bit clock for both transmitted and received data, while asynchronous modems don't require a clock and rely on the inherent framing provided by the start and stop bits. Normally, any modem 9600 bps or faster will be synchronous. The router can be connected to other remote routers to form a wide area network (WAN), using synchronous modems connected to the synchronous interfaces on the router's rear panel.

WAN links faster than 9600 bps are normally provided using Network Terminating Units (NTUs), which are always synchronous. The interface to these devices is generally X.21 or V.35.

Good quality data grade cables should be used for all cables, particularly X.21. This must be made from paired cable with an overall foil shield. Ideally, metalised backshells should also be used. Poor quality cables will limit the maximum speed or the maximum length of the cable, or both.

## Ethernet Interfaces

### 10BASE-T Interfaces

All AR300 Series routers have at least one 10BASE-T Ethernet LAN port. The AT-AR330 has two 10BASE-T Ethernet LAN ports. A rear panel slide switch (labelled MDX) allows the user to configure the LAN port for a direct connection to either a hub or personal computer. The same RJ-45 cable (supplied with the router) may be used in either situation.

The LAN ports can easily be tested using a simple external loopback plug. See "Cables And Loopback Plugs" on page 80 for details of how to construct a loopback plug.

### 10BASE-T/100BASE-TX Interfaces

The AT-AR026 4ETH PIC has four 10BASE-T/100BASE-TX ports with RJ-45 connectors. Port characteristics such as speed, flow control, half/full duplex, and auto-negotiation can be set by configuring links on the PIC's PCB. See the *PIC Hardware Reference* for more information. If your router has a PIC bay, the *PIC Hardware Reference* is included on the Documentation and Tools CD-ROM that shipped with your router, or it can be downloaded from [www.alliedtelesyn.co.nz/documentation/documentation.html](http://www.alliedtelesyn.co.nz/documentation/documentation.html).

## Ethernet Dual 10BASE-T/AUI Interfaces

The AT-AR022 ETH PIC has a dual 10BASE-T/AUI Ethernet interface. Only one Ethernet interface type can be active at any one time. The PIC auto-senses which Ethernet interface type is in use.



*The AUI interface is able to supply the required +12 Volts to attached transceivers. The +12 Volts is fused to prevent any transceiver faults from causing problems with the router. See the description of the appropriate router series in this Reference for the location of the fuse. The fuse must be a 500 mA type. If the fuse fails, LEDs on any attached transceiver will not be lit. The AUI cable should be checked for continuity problems if the fuse blows.*

## Basic Rate ISDN Interfaces

Basic Rate ISDN (BRI) interfaces support two 64K B channels and one D channel. On some routers and expansion cards the operational mode of the BRI ISDN interface (TE or NT) is determined by jumpers mounted on the CPU or expansion card. Other models and expansion cards—in particular those with U interfaces—only support TE mode.

See the description of the relevant router model in this Reference for details of the locations and names of jumpers. See the *Integrated Services Digital Network (ISDN)* chapter of your router's Software Reference for a detailed description of the two operational modes. The router should be configured as a TE for normal operation.

The jumpers used to determine interface termination are normally removed as the building wiring will provide the correct termination for an ISDN TE-to-NT circuit. When the BRI is connected in a point-to-point configuration, the jumpers may need to be installed to terminate the line pairs with internal 100Ω resistors.

See the description of the relevant router series (in this Reference) for details of the locations and names of jumpers. The *Integrated Services Digital Network (ISDN)* chapter of your router's Software Reference also has additional information. The BRI interface pin out is shown in Table 31 on page 76.



*If you are unsure of whether to terminate the line or not, contact your ISDN service provider or your authorised Allied Telesyn distributor or reseller.*

**Table 31: Pinout of the Basic Rate ISDN interface.**

| Pin | S/T Interface Functions | U Interface Functions |
|-----|-------------------------|-----------------------|
| 1   | -                       | -                     |
| 2   | -                       | -                     |
| 3   | TX+                     | -                     |
| 4   | RX+                     | positive (+)          |
| 5   | RX-                     | negative (-)          |
| 6   | TX-                     | -                     |
| 7   | -                       | -                     |
| 8   | -                       | -                     |

## Primary Rate ISDN Interfaces

Primary Rate ISDN interfaces on the AT-AR390 and AT-AR395 support connection to either 75Ω or 120Ω networks. The 75Ω interfaces conform to the standard BNC method of connection to 75Ω coaxial cable (Table 32 on page 77). Since there is currently no official international standard for “pluggable” connection to a 120Ω system, 120Ω interfaces employ the RJ-45 method of connection used by most other manufacturers (Table 33 on page 77).

Primary Rate ISDN interfaces on the AT-AR020 PRI E1/T1 PIC and AT-AR025 PRI/G.703 PIC support connection to 120Ω networks using the RJ-45 method of connection used by most other manufacturers (Table 33 on page 77). An external balun is required to connect to a 75Ω network.

**Table 32: Connection standard for Primary Rate ISDN BNC 75Ω connectors.**

| Signal  | Connection                     |
|---------|--------------------------------|
| TX-/RX- | Outer conductor (i.e., shield) |
| TX+/RX+ | Inner conductor                |

**Table 33: Connection standard for Primary Rate ISDN RJ-45 120Ω connectors (from left to right, with latch down, as viewed from the rear).**

| Pin | Signal                          |
|-----|---------------------------------|
| 1   | RX+                             |
| 2   | RX-                             |
| 3   | RX ground selection from jumper |
| 4   | TX+                             |
| 5   | TX-                             |
| 6   | TX ground selection from jumper |
| 7   | <i>Not connected</i>            |
| 8   | <i>Not connected</i>            |

## Voice Ports

Voice ports on the AT-AR300(S) and AT-AR310(S) use a standard RJ-11 telephone socket that provides a Tip and Ring A/B pair (Table 34 on page 77). An RJ-11-to-BT adaptor cable can be used to connect telephones with BT-style plugs to RJ-11 ports (Figure 55 on page 96).

**Table 34: Pinout of the voice port RJ-11 connectors.**

| Pin | Function             |
|-----|----------------------|
| 1   | <i>Not connected</i> |
| 2   | <i>Not connected</i> |
| 3   | RING                 |
| 4   | TIP                  |
| 5   | SHUNT                |
| 6   | <i>Not connected</i> |

## Test Facility

A Test Facility designed to test the router's physical interfaces is built into all AR router software. The test Facility can be thought of as a specialised interface module like PPP or Frame Relay. Although the router can continue to operate normally during specific tests, any interfaces being tested are dedicated to the Test Facility. For more information on the Test Facility's operation, see the *Test Facility* chapter of your router's Software Reference.

AR routers support a wide range of interface types, including Ethernet, asynchronous, synchronous, Basic Rate ISDN and Primary Rate ISDN. Each interface type (except Ethernet interfaces on the AT-AR026 PIC) can be tested independently using the Test Facility software. Most tests, however, will also require the use of a loopback plug. For more information on loopback plugs, see "Loopback Plugs for Testing Interfaces" on page 96.



*The Test Facility will not test AT-AR026 PICs.*

The following examples show how to test specific interfaces.

Test results are displayed with the command:

```
SHOW TEST
```

which produces a display like that shown in Figure 38 on page 78.

**Figure 38: Example output from the SHOW TEST command.**

| Board     | ID | Bay | Board Name       | Rev  | Serial number |
|-----------|----|-----|------------------|------|---------------|
| Base      | 62 |     | AR720            | M1-0 | 6845181       |
| IC Module | 38 | 0   | AR023 PIC Sync   | M1-1 | 5917086       |
| IC Module | 44 | 1   | AR025 PIC E1 PRI | M1-0 | 6843626       |
| MAC       | 68 |     | AR011 ECMAC      | P1-1 | 6804365       |

| Interface | State    | Result          | Type      | Duration (minutes) | Details Data( %OK ) | Control |
|-----------|----------|-----------------|-----------|--------------------|---------------------|---------|
| eth0      | halted   | * Active LAN    | trans     | < 1                | BAD ( 0.0)          | -       |
|           |          |                 | TP        | 0                  | -                   | -       |
|           |          |                 | ENDEC     | 0                  | -                   | -       |
|           |          |                 | MAC       | 0                  | -                   | -       |
| port0     | complete | good            | -         | 1000               | good( 99.0)         | good    |
| port1     | complete | good            | -         | 1000               | good( 99.0)         | good    |
| syn0      | testing  | wait continuous | RS-232dte | 355                | good(100.0)         | good    |
|           |          |                 | dce       | 355                | good(100.0)         | good    |
|           |          |                 | X.21 dte  | 354                | good(100.0)         | good    |
|           |          |                 | dce       | 0                  | -                   | -       |
|           |          |                 | V.35 dte  | 354                | good(100.0)         | good    |
|           |          |                 | dce       | 0                  | -                   | -       |
| PRI0      | halted   |                 | -         | < 1                | BAD ( 0.0)          | -       |
| mac0      | complete | good            | DES       | 4                  | good(100.0)         | -       |
| mac1      | complete | good            | STAC      | 4                  | good(100.0)         | -       |
| mac2      | complete | good            | ALL       | 4                  | good(100.0)         | -       |

## Asynchronous Interface Tests

Asynchronous interfaces require a loopback plug to be installed before the test will operate. See “*Cables And Loopback Plugs*” on page 80 for details of how to make a loopback plug. To start a test of an asynchronous interface, use the command:

```
ENABLE TEST INT=PORTn
```

where  $n$  is the interface number. This will run the test for 4 minutes. Use the SHOW TEST command (from the *Test Facility* chapter of your router’s Software Reference), to observe the test progress.

## Ethernet LAN Interface Tests



---

*The Test Facility will not test Ethernet interfaces on AT-AR026 PICs.*

---

A loopback plug is required to run the first part of the Ethernet LAN test. See “*Cables And Loopback Plugs*” on page 80 for details of how to make a loopback plug. To start a test of an Ethernet interface, use the command:

```
ENABLE TEST INT=ETHn
```

where  $n$  is the Ethernet interface number. This will run the test for 4 minutes. Use the SHOW TEST command (from the *Test Facility* chapter of your router’s Software Reference), to observe the test progress.

## WAN Port Tests

To fully test synchronous interfaces, an external tester (available from your authorised Allied Telesyn distributor or reseller) is required. A loopback plug is not required to test BRI interfaces.

To start a WAN interface test, use the command:

```
ENABLE TEST INT=SYNn
```

or

```
ENABLE TEST INT=BRIn
```

where  $n$  is the WAN interface number. This will run the test for 4 minutes. Use the SHOW TEST command (from the *Test Facility* chapter of your router’s Software Reference), to observe the test progress.



---

*If a test fails, please contact your authorised Allied Telesyn distributor or reseller.*

---

## Cables And Loopback Plugs

---

This section describes how to make cables for connecting the AR router to networks, terminals, and printers. It also describes loopback plugs, which are required for testing most AR router interfaces.

### Transition Cables for Network Interfaces

AR router synchronous ports use AMPLIMITE 50-way connectors wired as universal connectors to support RS-232/V.28, V.35 and X.21 interface standards. DTE and DCE modes are supported.

A transition cable is required to convert the AMPLIMITE to the correct physical interface for the standard required (e.g., DB15 for X.21). The transition cable can be ordered from your authorised Allied Telesyn distributor or reseller, or you can construct your own cable by following the wiring diagrams in this section.

The transition cable does more than simply change the physical connector. The router hardware 'reads' the cable type from the AMPLIMITE plug and enables or disables the internal driver electronics as required. To function correctly, the cables must be identical to the cables described in this section.



---

*The DCE cable type reverses the direction of data lines as well as clock lines. This cable is intended to be used when the router supplies the clock for an attached device. This is commonly used when the router is connected to the synchronous port of another router or a host, without using an intermediate modem or NTU (Network Terminating Unit). Therefore, the DCE cable must only be connected to a router port that is set to generate the clock. See the Interfaces chapter of your router's software Reference for more information. The AMPLIMITE connector supports both DTE and DCE modes for all three physical standards.*

---



---

*Please pay particular attention to V.35 connections. The router interface is fully compliant to V.35 but many DCE (DSU/CSU) devices are not. Because of the low signal levels used for V.35 (500mV point-to-point), issues such as ground loops and excess cable length become more important than with X.21. In particular, some DCE devices connect the cable ground to chassis or safety ground. This can create an earth loop condition through the shield wire of the V.35 interface. The symptom of this condition is unexpectedly high received packet errors (CRC, Abort, etc.) as seen in the `SHOW SYN=n COUNT` command's output. In these cases the suggested remedy is to break the earth loop by disconnecting (and isolating) pin A inside the M34 connector. This action does not compromise the safety of the product in any way.*

---

Transition cables can be changed at any time. It is not necessary to power-down the router.



---

*Good quality data grade cables should be used for all cables. All transition cables must be made from paired cable with an overall foil shield. Metalised backshells must also be used. Poor quality cables will limit the maximum speed or the maximum length of the cable, or both.*

---



*It is very important that the cables do not degrade EMC emission standards of the router (e.g., FCC, CISPR). The cable foil shield must be connected to the AMPLIMITE metalised backshell with a 360 degree ferrule. In addition, on specified cables, a clip-on cable ferrite must be attached to the cable at the AMPLIMITE end, no more than 25 mm from the rear of the backshell of the AMPLIMITE connector. Contact your authorised Allied Telesyn distributor or reseller for a list of approved ferrites.*

Table 35 on page 81 lists the wiring diagrams to follow when constructing transition cables for each physical interface standard.

**Table 35: Transition cable pin wiring diagrams.**

| <b>Physical Interface Standard</b> | <b>Pin Wiring Diagram</b> |
|------------------------------------|---------------------------|
| RS-232 DTE                         | Figure 39 on page 82      |
| RS-232 DCE                         | Figure 40 on page 83      |
| V.35 DTE                           | Figure 41 on page 84      |
| V.35 DCE                           | Figure 42 on page 85      |
| X.21 DTE                           | Figure 43 on page 86      |
| X.21 DCE                           | Figure 44 on page 87      |

Figure 39: Pin wiring diagram for an RS-232 DTE transition cable to an AMPLIMITE 50-way connector.

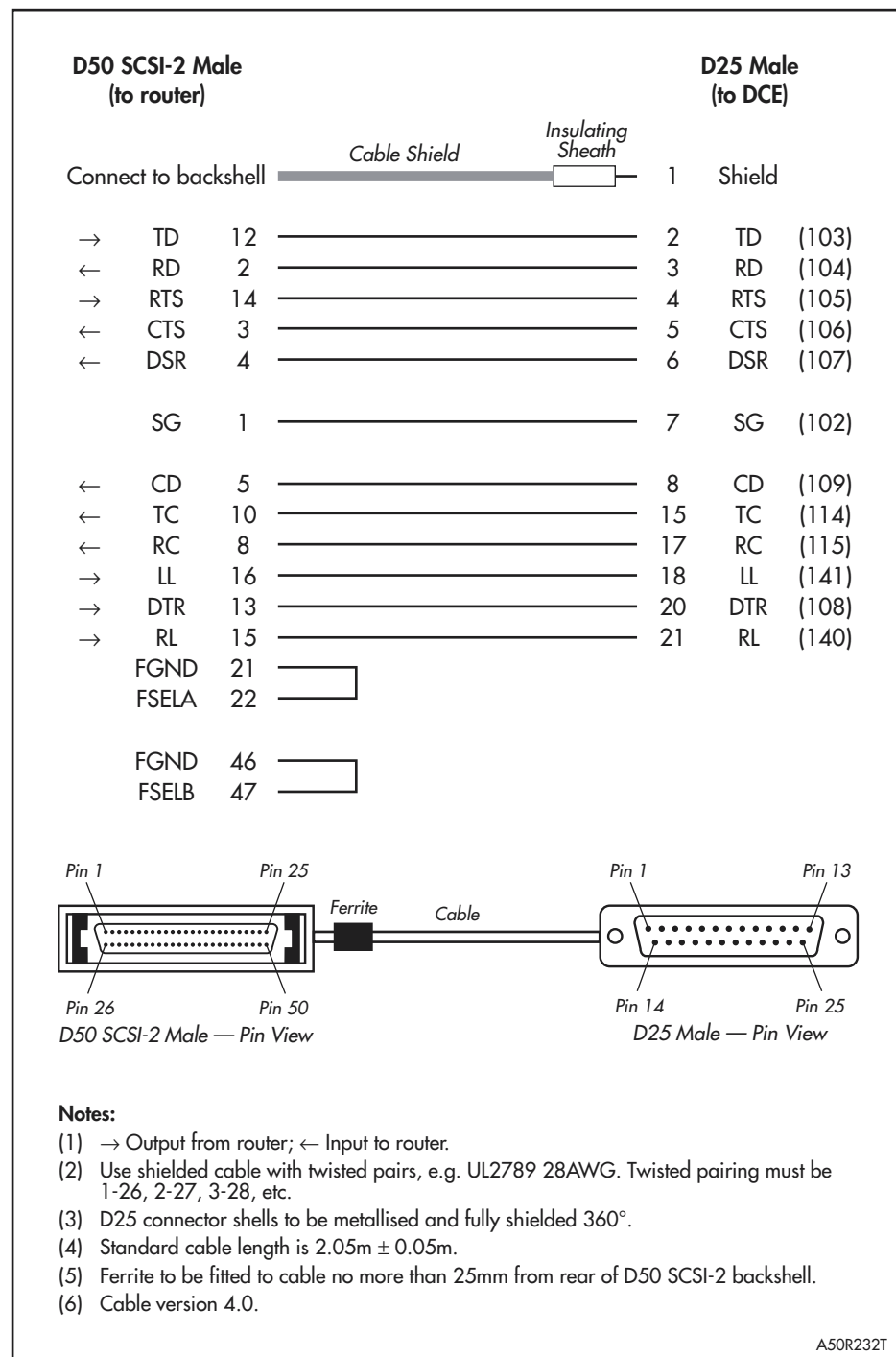

Figure 40: Pin wiring diagram for an RS-232 DCE transition cable to an AMPLIMITE 50-way connector.

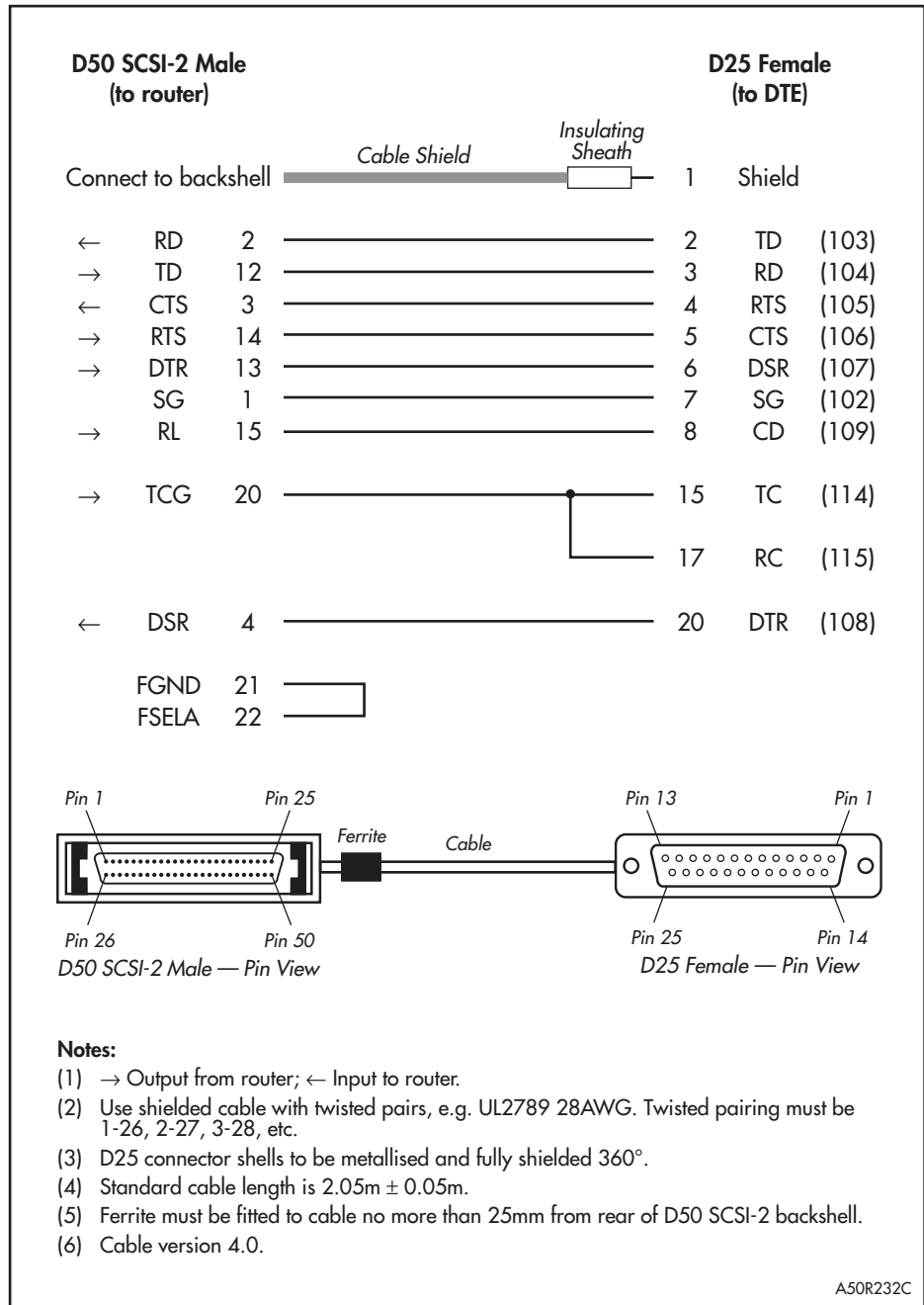
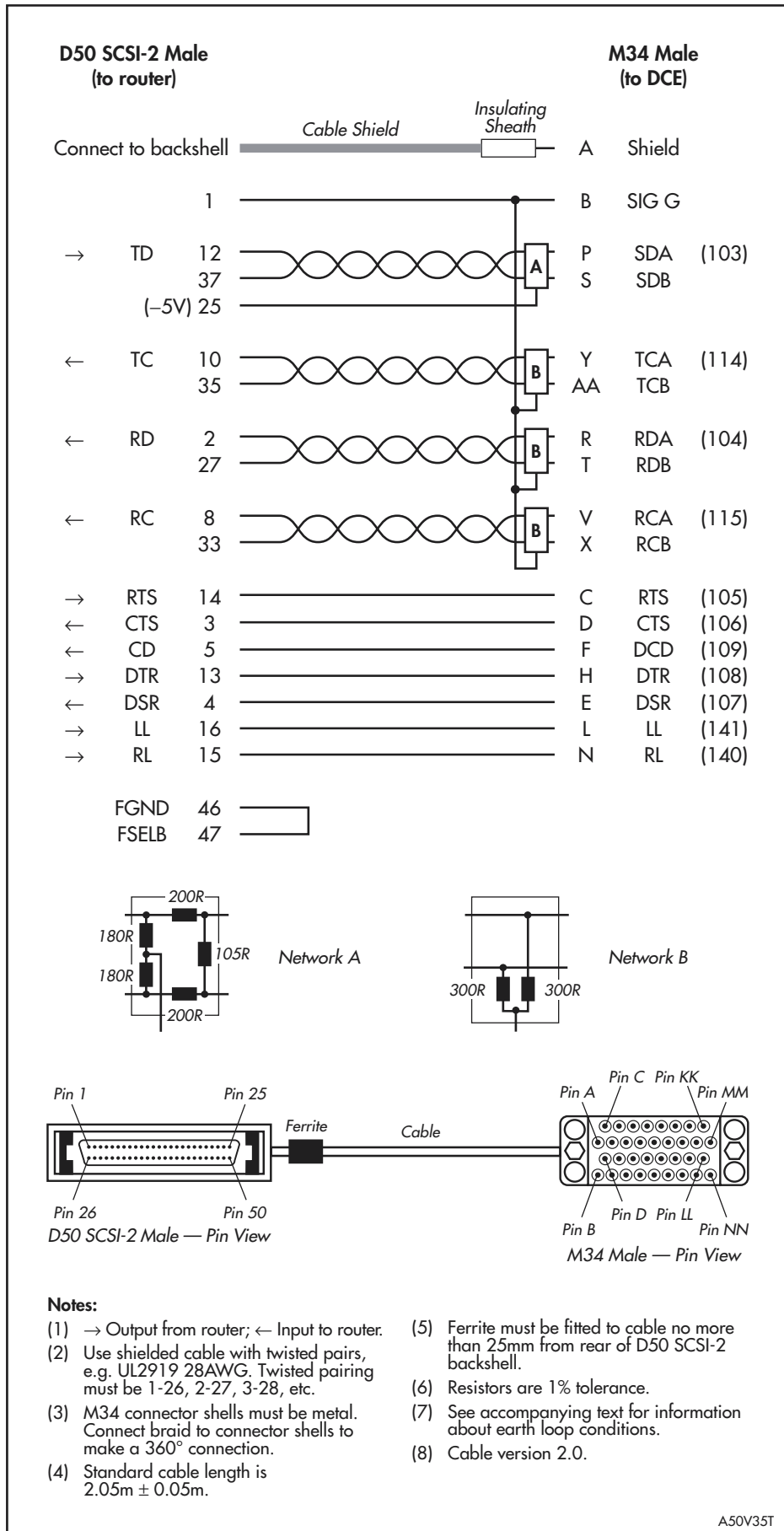

Figure 41: Pin wiring diagram for a V.35 DTE transition cable to an AMPLIMITE 50-way connector.



**Figure 42: Pin wiring diagram for a V.35 DCE transition cable to an AMPLIMITE 50-way connector.**

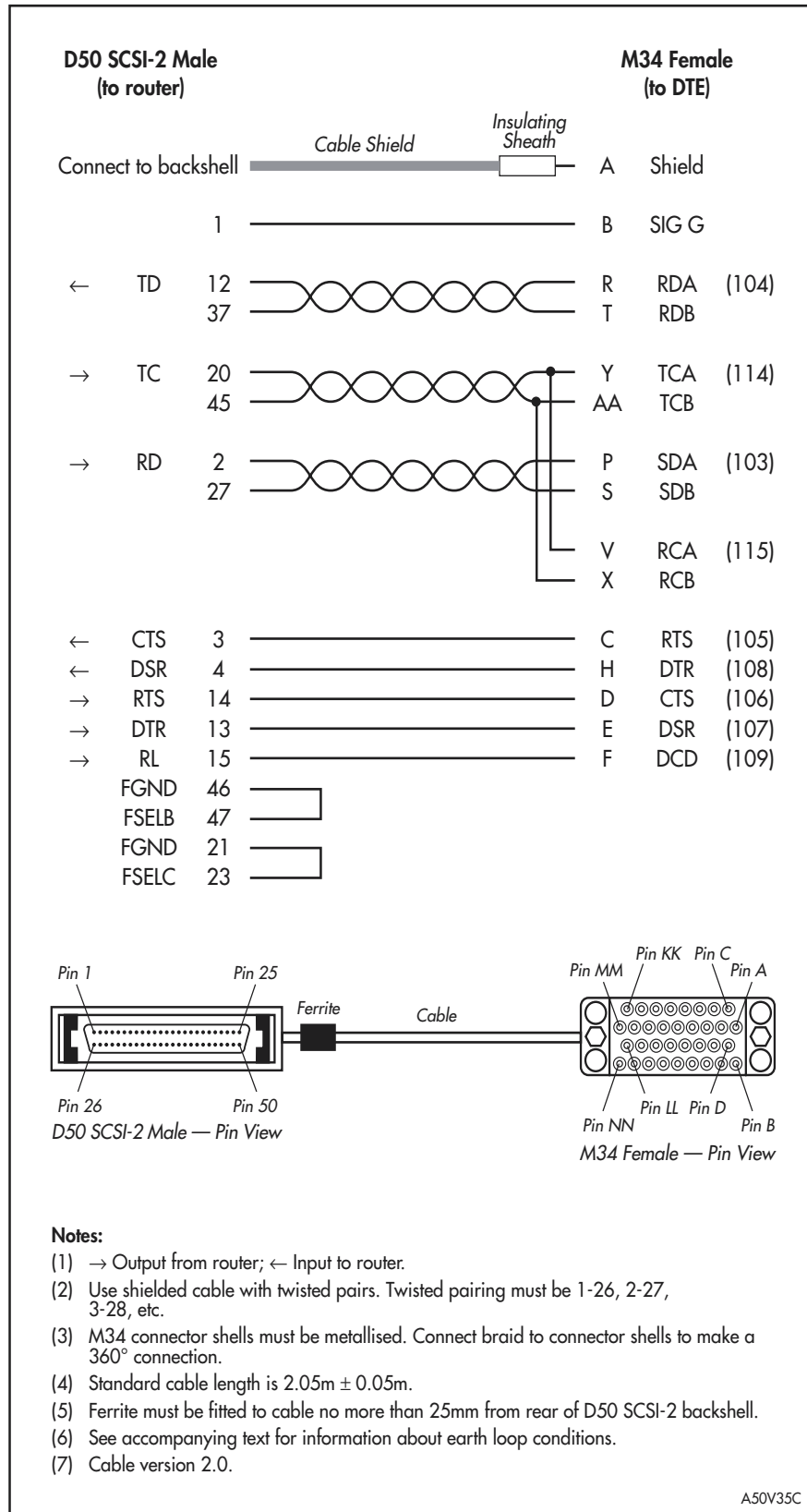

Figure 43: Pin wiring diagram for an X.21 DTE transition cable to an AMPLIMITE 50-way connector.

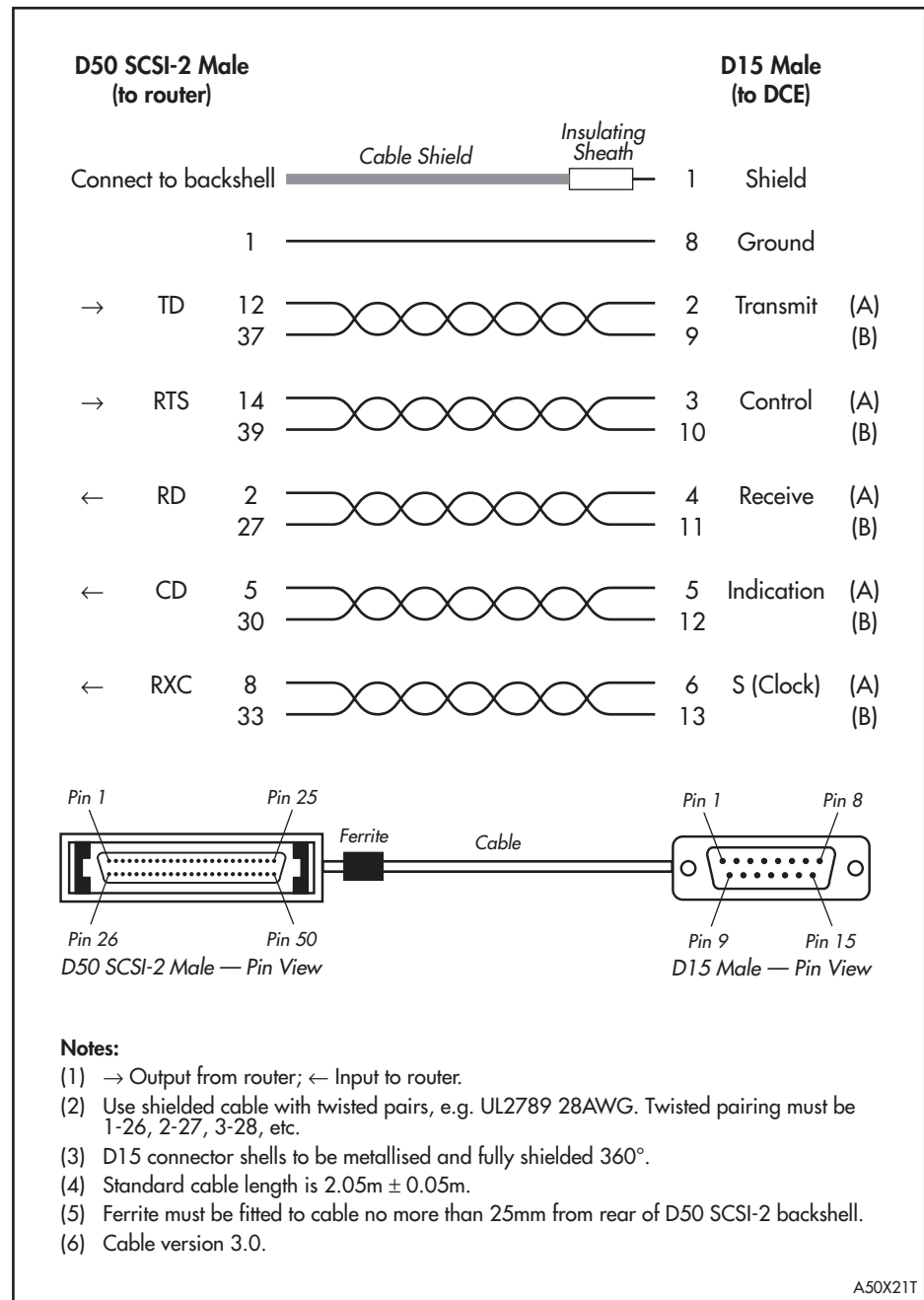
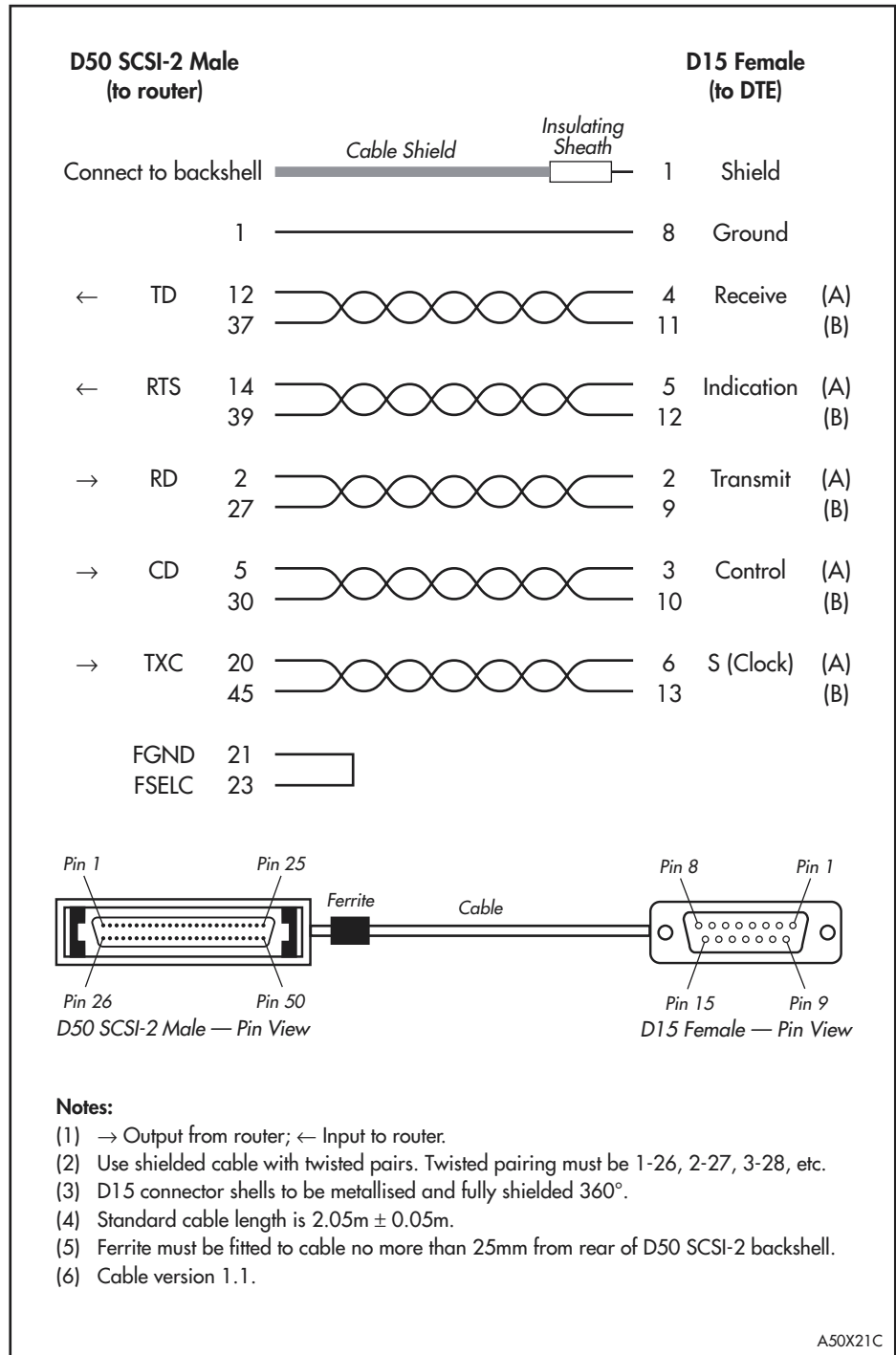

Figure 44: Pin wiring diagram for an X.21 DCE transition cable to an AMPLIMITE 50-way connector.



## ISDN Interface Cables

AR routers support two types of ISDN interface—Primary Rate Access and Basic Rate Access. Figure 45 on page 88 shows how to wire a cable to connect a Basic Rate Interface (BRI) to the ISDN network terminating equipment (NT).

**Figure 45: Pin wiring diagram for an ISDN Basic Rate Interface cable.**

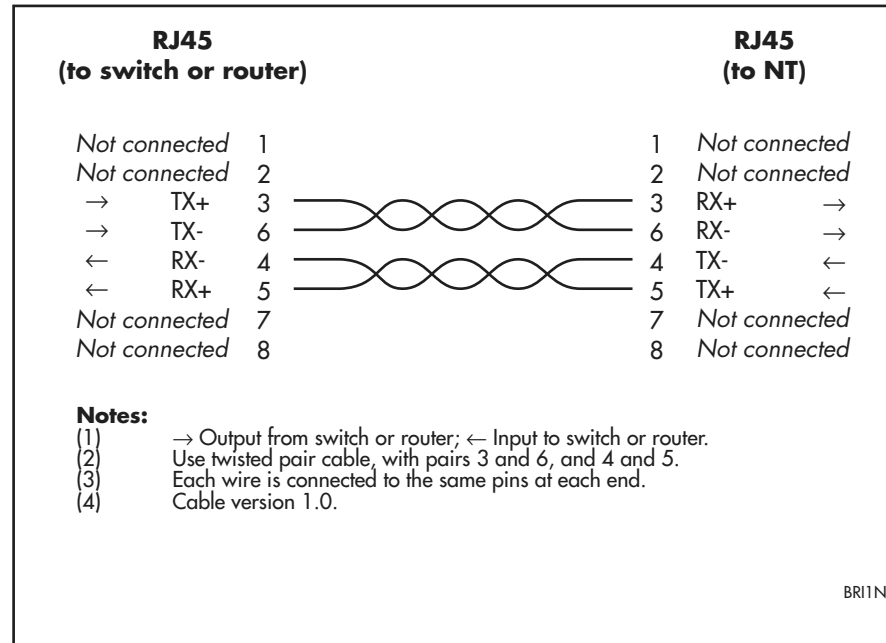

For Primary Rate Access there are two cabling options. Figure 46 on page 89 shows how to wire a cable to connect to the 120Ω connector of a Primary Rate Interface (PRI). Currently there is no accepted standard for the connector at the network termination end, so only the cable's router end is shown. Consult your ISDN service provider for more information.

Figure 47 on page 89 shows how to wire a cable to connect to the 75Ω connector of a Primary Rate Interface (PRI).



Table 36: Terminal and modem cables. (Continued)

| Cable                                     | Figure               |
|---|----------------------|
| RJ-45 (router) to DB25 male (modem) cable | Figure 53 on page 94 |
| R-J45 (router) to MiniDin (Macintosh)     | Figure 54 on page 95 |



*The RING input is only available on asynchronous ports on expansion cards. It is not available on asynchronous ports on base CPU boards.*

An alternative method, for both terminal and modem cables, is to wire an R-45 patch cord (a straight pin-to-pin cable with RJ-45 connectors on both ends) and then use an RJ-45-to-DB25 adaptor wired internally as a crossed cable. These adaptors are available in both DB25 female and male versions from data cabling suppliers, and are supplied with wires terminated on the RJ-45 socket and pins on the free ends. The pins are inserted into the appropriate positions in the DB25 shell.

Figure 48: Pin wiring diagram for a standard RJ-45 terminal cable.

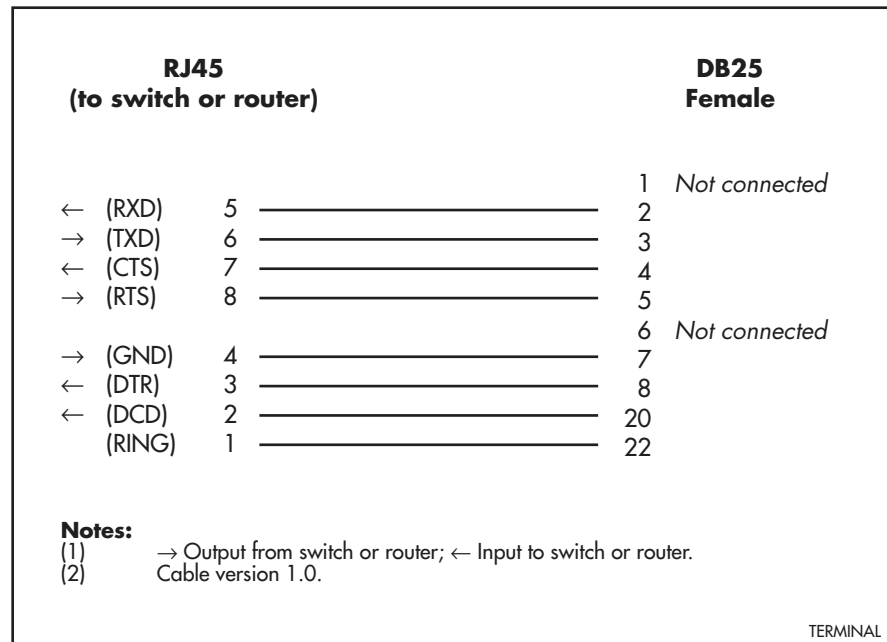

Figure 49: Pin wiring diagram for a standard DB9 male terminal cable.

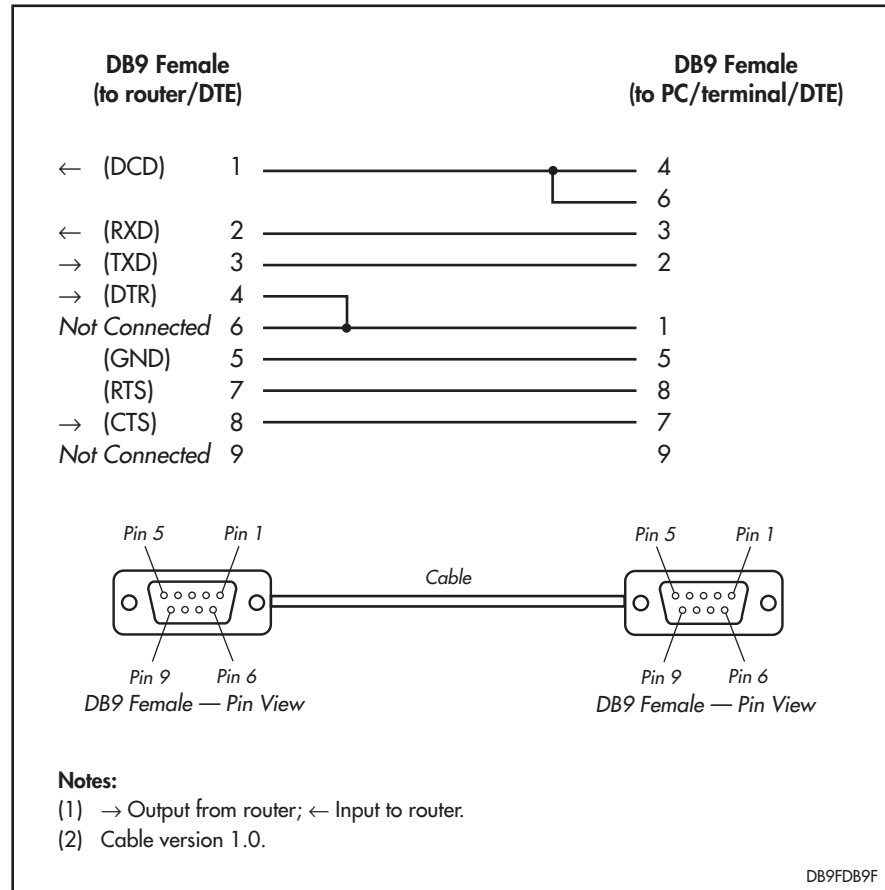
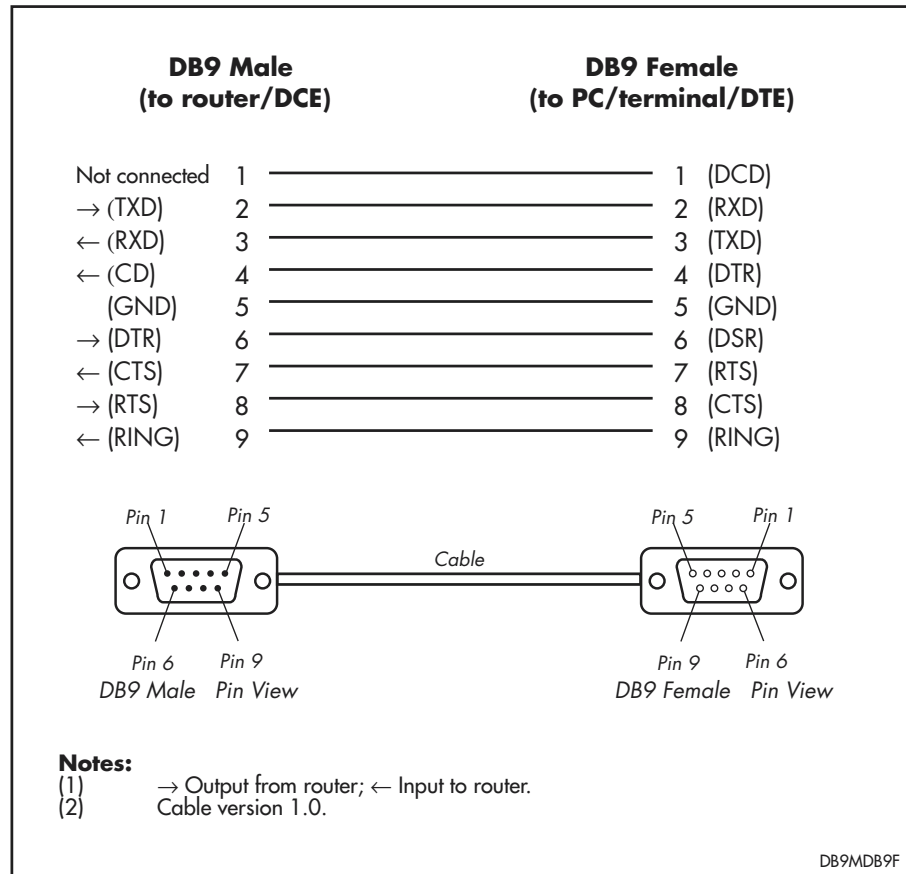

Figure 50: Pin wiring diagram for a standard DB9 male to female terminal cable.



While the asynchronous port (on router models with one asynchronous port) has a DCE female socket, the router's internal electronics regard the port as DTE. Signals displayed using the SHOW PORT command therefore have a DTE perspective. The internal DTE pin roles are listed in Table 37 on page 92.

Table 37: Internal DTE pin roles

| Pin | Role |
|-----|------|
| 2   | TXD  |
| 3   | RXD  |
| 4   | CD   |
| 5   | GND  |
| 6   | DTR  |
| 7   | CTS  |
| 8   | RTS  |

Figure 51: Pin wiring diagram for a DTE asynchronous port (DB9 male) to modem (DCE) cable.

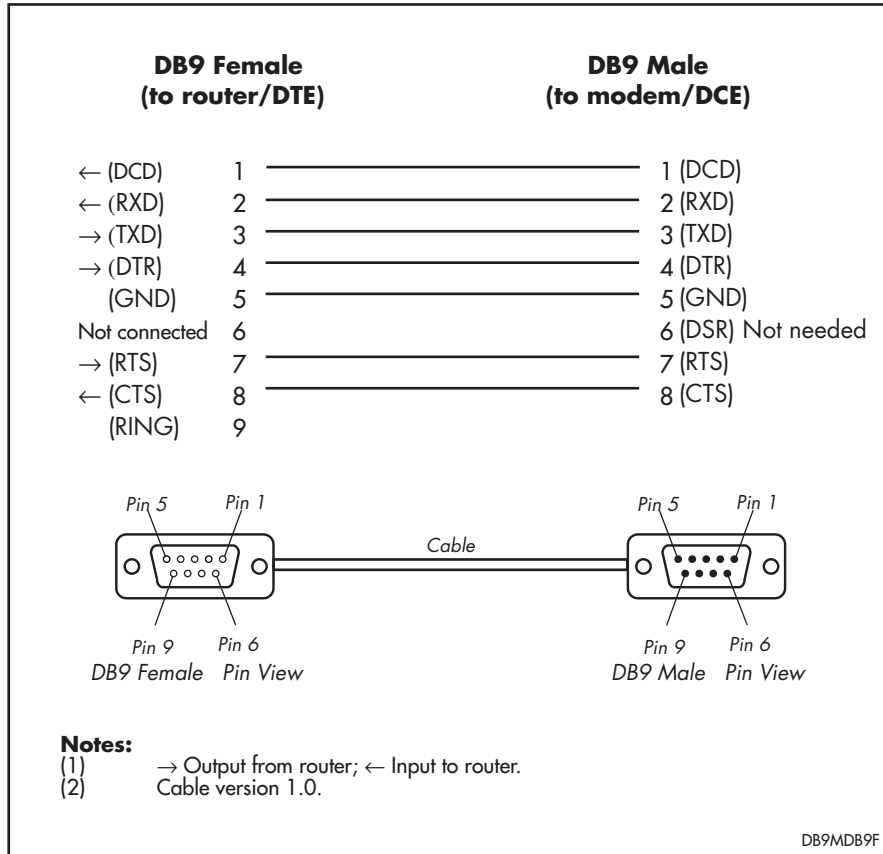

Figure 52: Pin wiring diagram for a DCE asynchronous port (DB9 female connector) to modem cable.

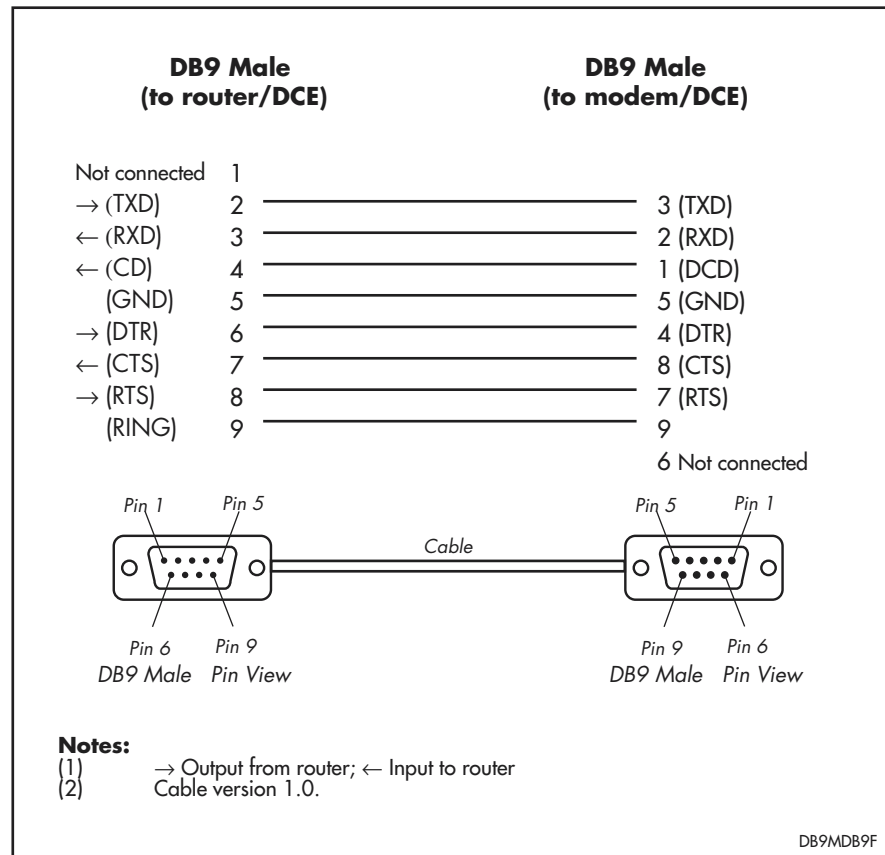

Figure 53: Pin wiring diagram for a standard modem cable.

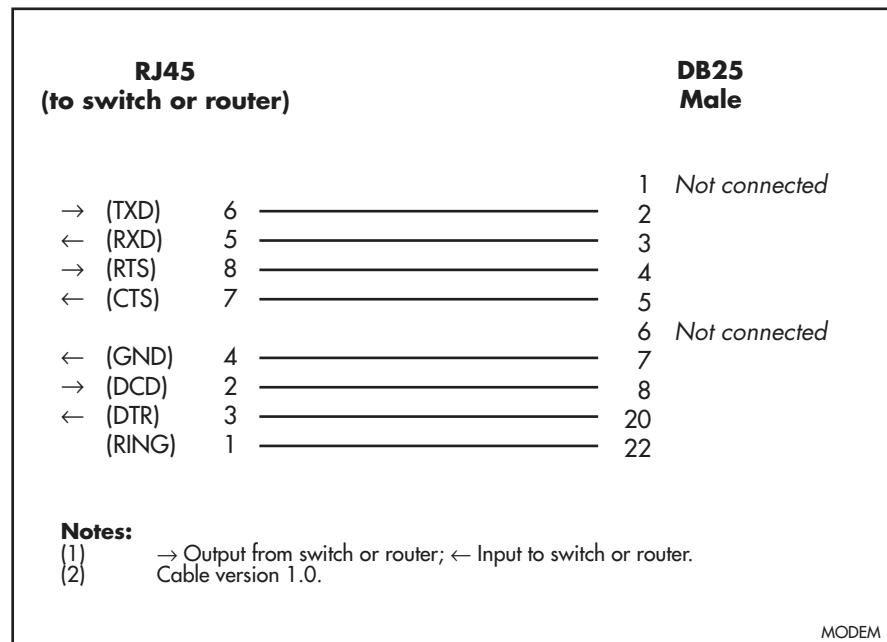
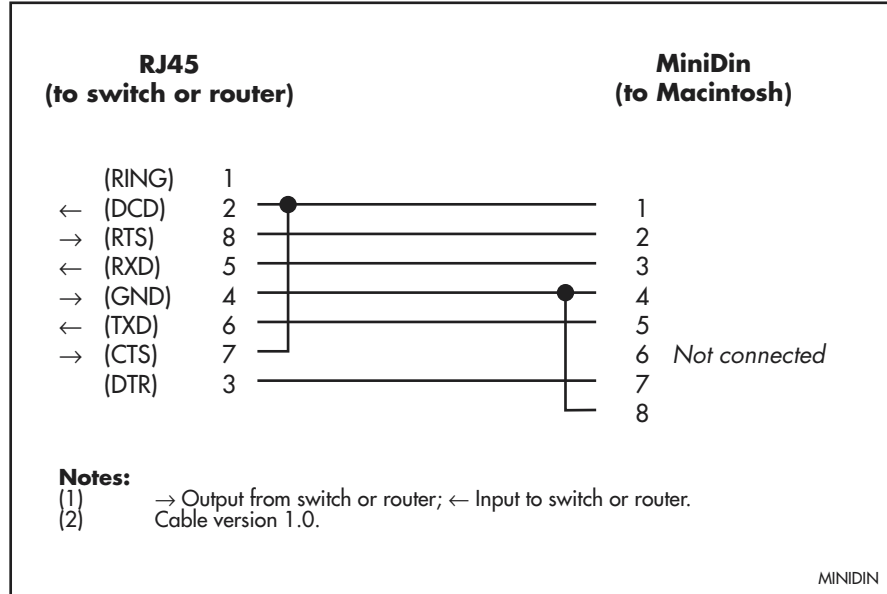

Figure 54: Pin wiring diagram for a Macintosh serial cable.



## Transceivers and AUI Cables

There are four types of Ethernet transceiver available (Table 38 on page 95). The 10BASE-5 thick Ethernet transceiver will be remote from the router, due to the nature of the coaxial cable, and will therefore require an AUI cable. The other types of transceiver may be connected using an AUI cable or, if the transceiver is small and lightweight, it may be connected directly to the AUI port on the back of the router. If this is done, care must be taken to avoid strain on the AUI port connector.

Table 38: Ethernet transceivers, media, and connector types.

| Type     | Media                               | Connector               |
|----------|-------------------------------------|-------------------------|
| 10BASE-2 | Thin Ethernet coaxial cable         | BNC                     |
| 10BASE-T | Twisted pair (category 3 or better) | RJ-45                   |
| 10BASE-F | Fibre optic (dual)                  | ST or SMA               |
| 10BASE-5 | Thick Ethernet coaxial cable        | Vampire TAP or "N" type |

AR routers may also be connected to a network via an AUI fanout. This device has multiple AUI ports wired as transceiver AUIs and a single standard AUI for connection of a transceiver. This arrangement allows several Ethernet devices to share a single transceiver. An AUI cable is required if this method is used.

Transceivers have a switch or a jumper to enable or disable SQE (*Signal Quality Error*, also known as heartbeat). AR routers do not require SQE, so it should be disabled.

AUI cables (sometimes known as drop or transceiver cables) are available from data cabling suppliers in a variety of lengths up to a maximum of 40 metres, but are typically between one and five metres in length. AUI cables always have one female and one male DB15 connector and are fitted with slide lock retaining clips to ensure a secure attachment.

## Voice Ports and Adaptor Cables

Voice ports use a standard RJ-11 connector. To connect telephones with a BT-style connector, use an RJ-11-to-BT adaptor cable (Figure 55 on page 96).

**Figure 55: Pin wiring diagram for an RJ-11 to BT adaptor cable.**

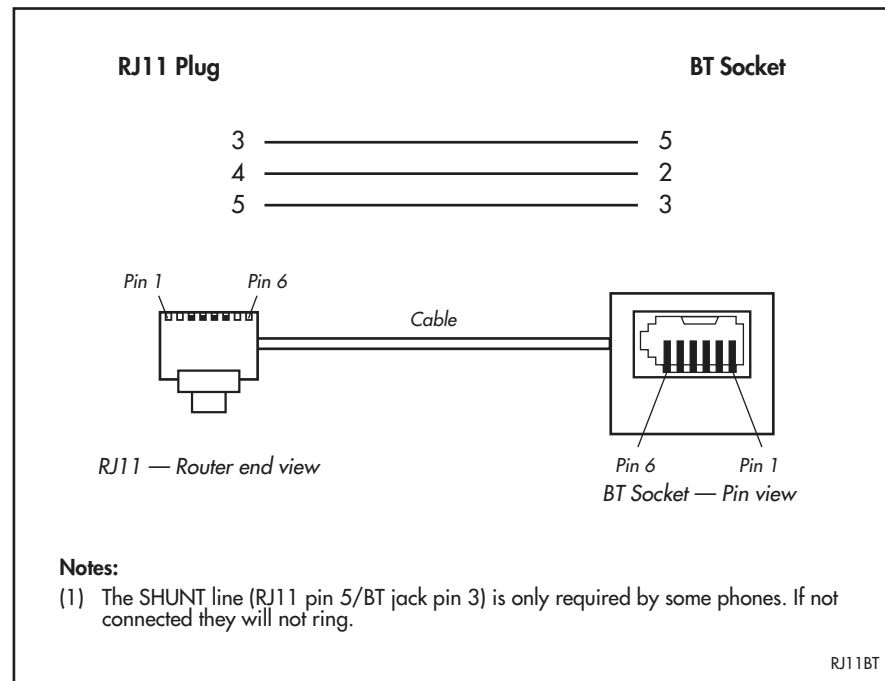

## Loopback Plugs for Testing Interfaces

Loopback plugs are used in conjunction with the Test Facility software (see the *Test Facility* chapter) to test the router's physical interfaces. The purpose of a loopback plug is to connect the output pins on the interface to the input pins so that any data transmitted over the interface is looped back and received at the same interface.

On interfaces with control signals, these are also looped back. The data received on the interface is compared with the data transmitted to determine whether or not the interface is functioning correctly. In order to produce a comprehensive test report, most tests performed by the Test Facility require a loopback plug to be inserted in the interface being tested.

Some interfaces (e.g., the synchronous ports) require a specially built external testing device (available from your authorised Allied Telesyn distributor or reseller) to be used in conjunction with the Test Facility.

Table 39 on page 96 lists the loopback plug wiring diagrams for each interface type.

**Table 39: Loopback plug pin wiring diagrams.**

| Physical Interface           | Loopback Method/Pin Wiring Diagram |
|------------------------------|------------------------------------|
| RJ-45 asynchronous interface | Figure 56 on page 97               |
| DB9 Male                     | Figure 57 on page 97               |
| DB9 Female                   | Figure 58 on page 98               |

**Table 39: Loopback plug pin wiring diagrams. (Continued)**

| Physical Interface          | Loopback Method/Pin Wiring Diagram   |
|-----------------------------|--|
| Ethernet AUI interface      | Figure 59 on page 98   |
| Ethernet TP interface       | Figure 60 on page 98   |
| Basic Rate ISDN interface   | Figure 63 on page 100. Most BRI interfaces are tested without a loopback plug. See "Loopback Plugs for BRI Interfaces" on page 99 for instructions on how to determine if a loopback plug is required. |
| Primary Rate 75Ω interface  | Use a length of terminated cable as a loopback cable on the interface.   |
| Primary Rate 120Ω interface | Figure 61 on page 99   |

**Figure 56: RJ-45 loopback plug for testing asynchronous interfaces.**

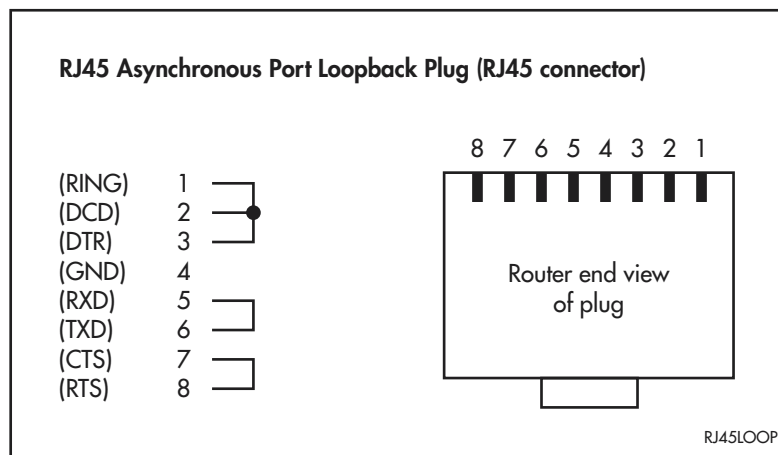

**Figure 57: DB9 female loopback plug for testing asynchronous ports with DB9 male connectors.**

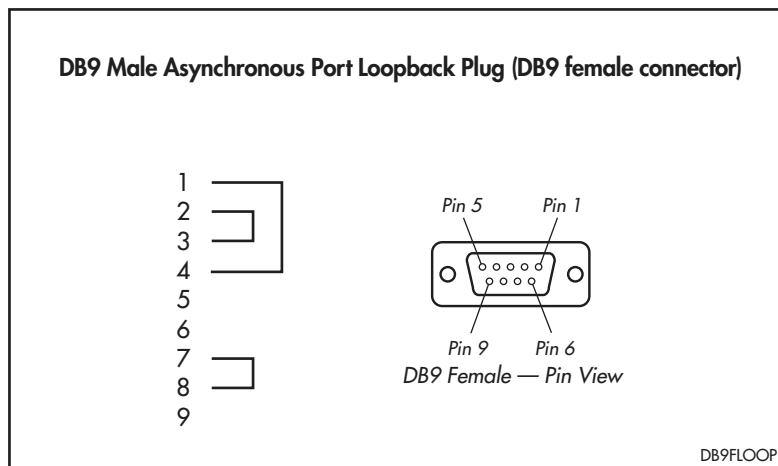

Figure 58: DB9 male loopback plug for testing asynchronous ports with DB9 female connectors.

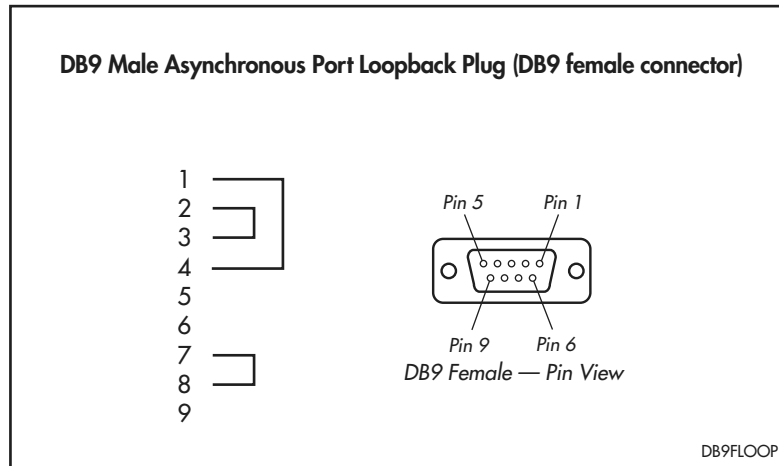

Figure 59: Ethernet AUI loopback plug.

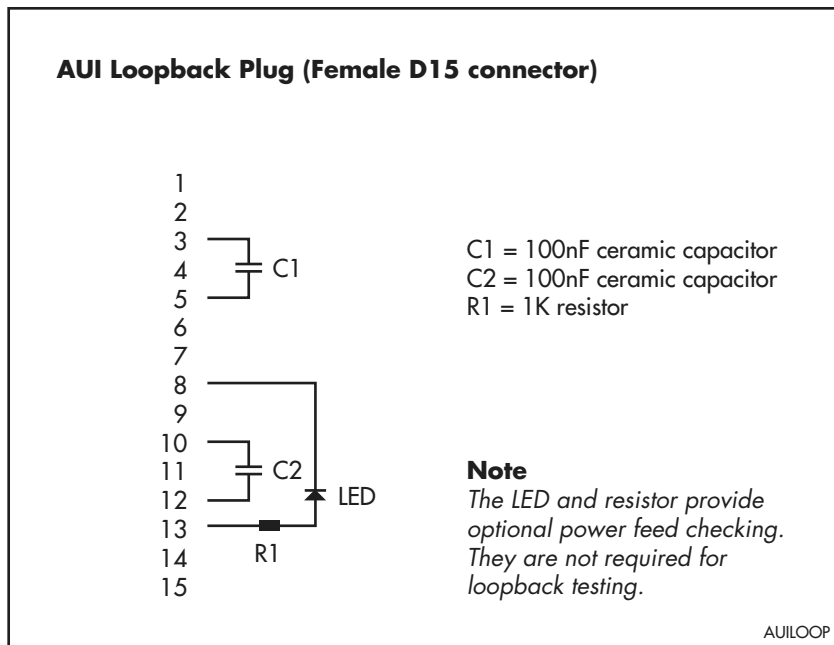

Figure 60: Ethernet twisted pair (TP) loopback plug.

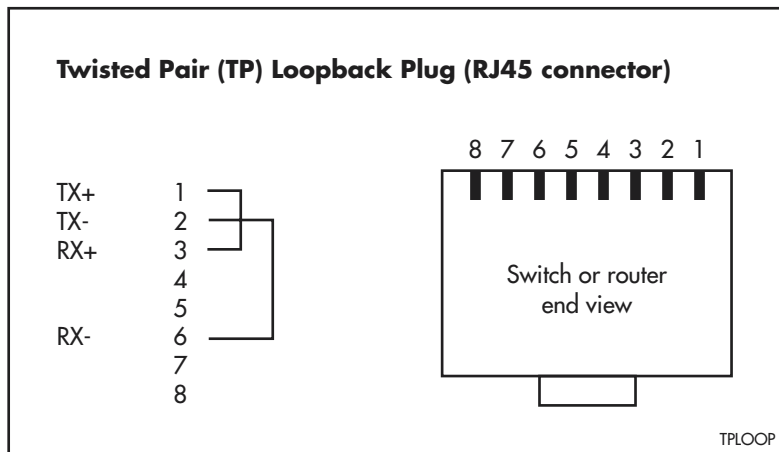
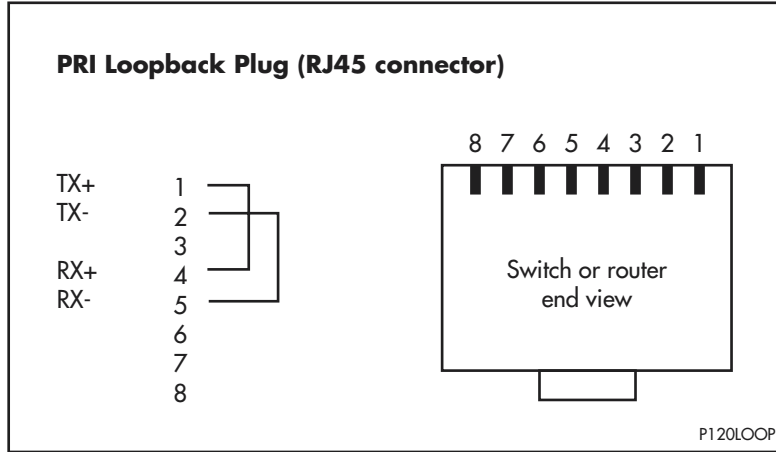

Figure 61: Primary Rate ISDN 120Ω loopback plug.



### Loopback Plugs for BRI Interfaces

If your router or expansion option's BRI interface has an MC145474 or MC145574 transceiver, a loopback plug is required before the BRI interface can be tested. (Figure 63 on page 100 shows how to wire a suitable loopback plug.)

For all other transceiver types the test can be performed without a loopback plug. In this case the Test Facility will still perform an internal loopback test, but this will not test the complete physical interface. To fully test these interfaces, an external NT mode device is required. Or, if the interface can be configured for NT mode operation, an external TE device can be used.

To determine which type of transceiver a BRI interface uses, enter the command:

```
SHOW BRI TEST
```

Figure 62 on page 99 shows an example of the output screen from the SHOW BRI TEST command, with the transceiver type listed in the first line.

Figure 62: Example output from the SHOW BRI TEST command.

```
Test switches for BRI instance 0 (MC145574 transceiver):
Number      Action                                          Status
-----
 1  Transceiver B1 GCI Transp Loop ..... no
 2  Transceiver B2 GCI Transp Loop ..... no
 3  Transceiver 2B+D GCI Transp Loop ..... no
 4  Transceiver B1 GCI Non-Transp Loop ..... no
 5  Transceiver B2 GCI Non-Transp Loop ..... no
 6  Transceiver B1 S/T Transp Loop ..... no
 7  Transceiver B2 S/T Transp Loop ..... no
 8  Transceiver B1 S/T Non-Transp Loop ..... no
 9  Transceiver B2 S/T Non-Transp Loop ..... no
10  Transceiver External S/T Loop ..... no
11  Transceiver 96kHz Test Tone ..... no
12  Transceiver Force Activation ..... no
13  Transceiver Ignore D Channel Procs ..... no
14  Transceiver Map E Channel to GCI ..... no
15  Transceiver GCI Free Run ..... no
```

Figure 63: Basic Rate ISDN loopback plug wiring diagram.

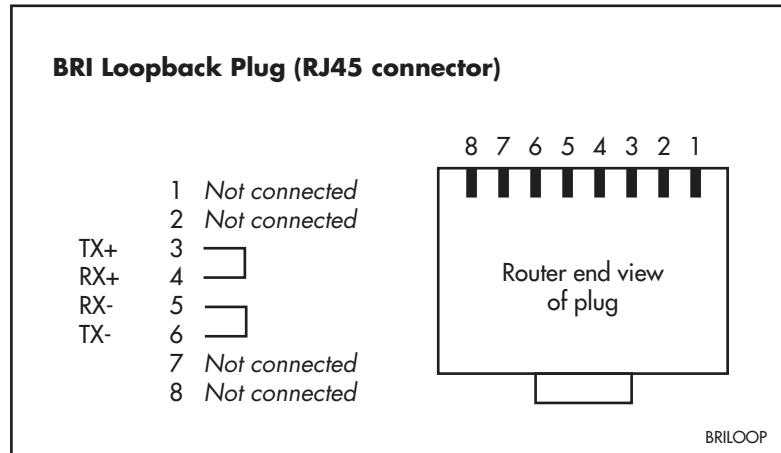

## PICs and NSMs

PICs (Port Interface Cards) can be installed in some AR400 Series routers and all AR700 Series routers. The sections describing each router model (earlier in this Reference) list which PICs can be installed in each model of router. Installation information for PICs can be found in the *Port Interface Card Quick Install Guide*. Detailed PIC hardware information can be found in the *Port Interface Card Hardware Reference*.

NSMs can be installed in AR740 and AR745 routers. Installation information for NSMs can be found in the *Network Service Module Quick Install Guide*. Detailed NSM hardware information can be found in the *Network Service Module Hardware Reference*.

The PIC and NSM Quick Install Guides and Hardware References are included on the Documentation and Tools CD-ROM bundled with all AR400 Series and AR700 Series routers. They can also be downloaded from the AR Router Support Site at [www.alliedtelesyn.co.nz/documentation/documentation.html](http://www.alliedtelesyn.co.nz/documentation/documentation.html).

## Restricted Procedures

This section contains procedures that should only be performed by authorised service personnel. Unauthorised use of procedures in this section may cause danger of injury from electric shock, damage to the router, and invalidation of the product warranty.

If you would like to know more about the procedures outlined in this section, please contact your authorised Allied Telesyn distributor or reseller.

## Installing a MAC

MACs can be installed in all AR300 and AR400 series routers, and AR740 routers, one MAC per router.



---

*MACs should only be installed by authorised service personnel. Unauthorised opening of the router lid may cause danger of injury from electric shock, damage to the router, and invalidation of the product warranty.*

---

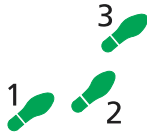

#### Before installing a MAC:

- 1. Check that you have the correct tools and equipment.**  
You will need a medium-sized posidrive screwdriver.
- 2. Avoid injury by working in a safe environment.**  
The workspace should be free of hazards, and there should be sufficient room to lay out the router, the MAC, and the tools.
- 3. Unpack the MAC in an antistatic environment.**



---

*Do not attempt to install any hardware option without observing correct antistatic procedures. Failure to do so may damage the router or hardware option. If you are unsure what the correct procedures are, contact your authorised Allied Telesyn distributor or reseller.*

---

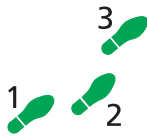

#### To install a MAC:

- 1. If connected, disconnect the router's RPS power supply.**
- 2. Turn off the router and remove the mains power cord.**



---

*Before removing the router's lid, the power cord and, if connected, RPS power cord should be disconnected to reduce risk of electrical shock.*

---

- 3. Remove all interface cables.**
- 4. Remove the router lid.**  
The router lid is secured by posidrive screws. Remove the screws and lift the lid off the chassis.  
The router may need to be removed from any racking system before the lid can be removed.
- 5. Insert the MAC.**  
Position the MAC in the MAC slot on the router base card, making sure that the support pillars located on the router base card are aligned with the holes provided on the MAC. This ensures that the connector on the MAC is correctly aligned with the slot on the router base card.  
Press the connector firmly into place. Secure the MAC using the fasteners supplied.
- 6. Replace the router lid and the power cord.**  
Secure the router's lid, then reconnect the power cord. If you disconnected an RPS supply or interface cables, reconnect them now.  
The MAC is now ready to test.

## Testing a MAC

There are several ways to check that the MAC is installed and operating correctly. First, check that the router has recognised the card. Turn on the router and enter the command:

```
SHOW SYSTEM
```

to display system information (Figure 64 on page 103).

The first part of the display shows details of the cards installed in the router. There should be at least two entries, one for the router base card and one for the MAC. Both the serial number and the part name should be displayed.

If there is no entry for the MAC then the router's boot process has not correctly detected the MAC's presence. The most likely cause is that the MAC is not plugged into the slot on the base card correctly. Repeat the installation process, paying particular attention to Step 5.

Use the SHOW SYSTEM command again, and if the display is still not correct, contact your authorised Allied Telesyn distributor or reseller.



---

*If you have any difficulty with the MAC at any time, contact your authorised Allied Telesyn distributor or reseller and quote the serial numbers of both the base card and the MAC. The serial number and revision details can be read using the SHOW SYSTEM command. It's a good idea to record this information for later reference.*

---

**Figure 64: Example output from the SHOW SYSTEM command for an AR720 router with an AT-AR011 V2 ECMAC installed.**

```

Router System Status                               Time 06:58:43 Date 15-Jun-2001.
Board      ID  Bay Board Name                          Rev   Serial number
-----
Base       62      AR720                               M1-0  40272628
PIC        75    0  AT-AR020-00 PIC E1/T1 PRI                     M1-0  42189364
MAC        155      AR011 ECMAC v2                       M2-0  33636408
-----
Memory -   DRAM : 16384 kB   FLASH : 4096 kB
-----
SysDescription
CentreCOM AR720 version 2.2.2-00 18-May-2001
SysContact

SysLocation

SysName

SysDistName

SysUpTime
1482 ( 00:00:14 )
Software Version: 2.2.2-00 18-May-2001
Release Version : 2.2.2-00 18-May-2001
Release built   : Jun 6 2001 at 00:54:54
Patch Installed : NONE
Territory      : japan
Help File      : help.hlp

Boot configuration file: mike.cfg (exists)
Current configuration: mike.cfg
Security Mode   : Disabled

Patch files
Name           Device      Size      Version
-----
52203.paz      flash      8428      2.0-1
52203pac.paz   flash      12988     2.0-1
-----

```

Next, check the MAC's status using the command:

```
SHOW LOG
```

to display a log of MAC events. A typical display is shown in Figure 65 on page 103.

**Figure 65: Example output from the SHOW LOG command for an AR720 router with an AT-AR011 V2 ECMAC card installed.**

```

Date/Time   S Mod  Type  SType Message
-----
15 06:58:28 4 ENCO ENCO  MAC   7711 Found. Initialisation started
15 06:58:28 4 ENCO ENCO  MAC   7711 Initialisation Successful
15 06:58:28 7 SYS  REST  NORM  Router startup, ver 2.2.2-00, 18-May-2001, Clock
Log: 12:52:42 on 08-Jun-2001
15 06:58:28 6 PRI  PINT  WARN  pri<0>: interface reset
15 06:58:31 6 PRI  PINT  UP    pri<0>: Interface is now operational
-----

```



*If any MAC tests fail, check that the MAC is correctly installed in its slot and repeat the tests. Contact your authorised Allied Telesyn distributor or reseller if the MAC does not operate correctly.*

Once the MAC is operating, its functionality can be tested either by using the Test Facility software, which is built into the router, or by configuring a module to use the MAC. For more information about configuring interfaces, see the “Compression and Encryption Services” chapter of your router’s Software Reference.

## Using the Test Facility to Verify Operation

The built-in Test Facility software is the easiest way to verify the operation of a MAC.



*See the Test Facility chapter of your router’s Software Reference for more information about the Test Facility.*

To run the Test Facility for a MAC, use the command:

```
ENABLE TEST INTERFACE=MAC
```

The test will run for 4 minutes. To view the results of the test at any time, use the command:

```
SHOW TEST
```

Figure 66 on page 104 shows a typical output. The status of the test will be shown in the right-hand column. For further information on the meanings of the other figures, see the “Test Facility” chapter of your router’s Software Reference.

**Figure 66: Example output from the SHOW TEST command for an AR720 router with an AT-AR011 V2 ECMAC installed.**

| Board | ID  | Bay | Board Name                | Rev  | Serial number |
|-------|-----|-----|---------------------------|------|---------------|
| Base  | 62  |     | AR720                     | M1-0 | 40272628      |
| PIC   | 75  | 0   | AT-AR020-00 PIC E1/T1 PRI | M1-0 | 42189364      |
| MAC   | 155 |     | AR011 ECMAC v2            | M2-0 | 33636408      |

| Interface | State    | Result | Type | Duration (minutes) | Details Data( %OK ) | Control |
|-----------|----------|--------|------|--------------------|---------------------|---------|
| eth0      | no test  | -      | -    | -                  | -                   | -       |
| asyn0     | no test  | -      | -    | -                  | -                   | -       |
| asyn1     | no test  | -      | -    | -                  | -                   | -       |
| PRI0      | no test  | -      | -    | -                  | -                   | -       |
| enco0     | complete | good   | DES  | 4                  | good(100.0)         | -       |
| enco1     | complete | good   | STAC | 4                  | good(100.0)         | -       |

If you are unsure about running the Test Facility, or have difficulty evaluating the results then contact your authorised Allied Telesyn distributor or reseller.

## Installing a PAC

PACs can be installed in AR725, AR740, and AR745 routers, one PAC per router.



---

*PACs should only be installed by authorised service personnel. Unauthorised opening of the router's lid may cause danger of injury from electric shock, damage to the router, and invalidation of the product warranty.*

---

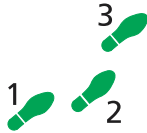

### Before installing a PAC:

1. **Check that you have the correct tools and equipment.**

You will need a medium-sized posidrive screwdriver.

2. **Avoid injury by working in a safe environment.**

The workspace should be free of hazards, and there should be sufficient room to lay out the router, PAC, and tools.

3. **Unpack the PAC in an antistatic environment.**



---

*Do not attempt to install any hardware without observing correct antistatic procedures. Failure to do so may damage the router or PAC. If you are unsure what the correct procedures are, contact your authorised Allied Telesyn distributor or reseller.*

---

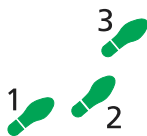

### To install a PAC:

1. **If connected, disconnect the router's RPS power supply.**

2. **Turn off the router and remove the mains power cord.**



---

*Before removing the router's lid, the power cord and, if connected, RPS power cord should be disconnected to reduce risk of electrical shock.*

---

3. **Remove all interface cables.**

4. **Remove the router's lid.**

The router lid is secured by four posidrive screws, two on each side, plus two on top of the case.

The router may need to be removed from any rack mounting system before the lid can be removed.

5. **If not already installed, install the PAC pillars.**

PAC mounting pillars are normally installed when the router is manufactured. If the pillars aren't installed, use the metal pillars that ship with each PAC (not the plastic pillars).

Carefully screw the pillars into the three threaded pillar mounts on the router's base board. The pillars should be firm but not over tight.

Figure 67 on page 106 shows the PAC pillar mounts on an AR740 base board.

Figure 67: Location of PAC slot and pillar mounts on an AR740 base board.

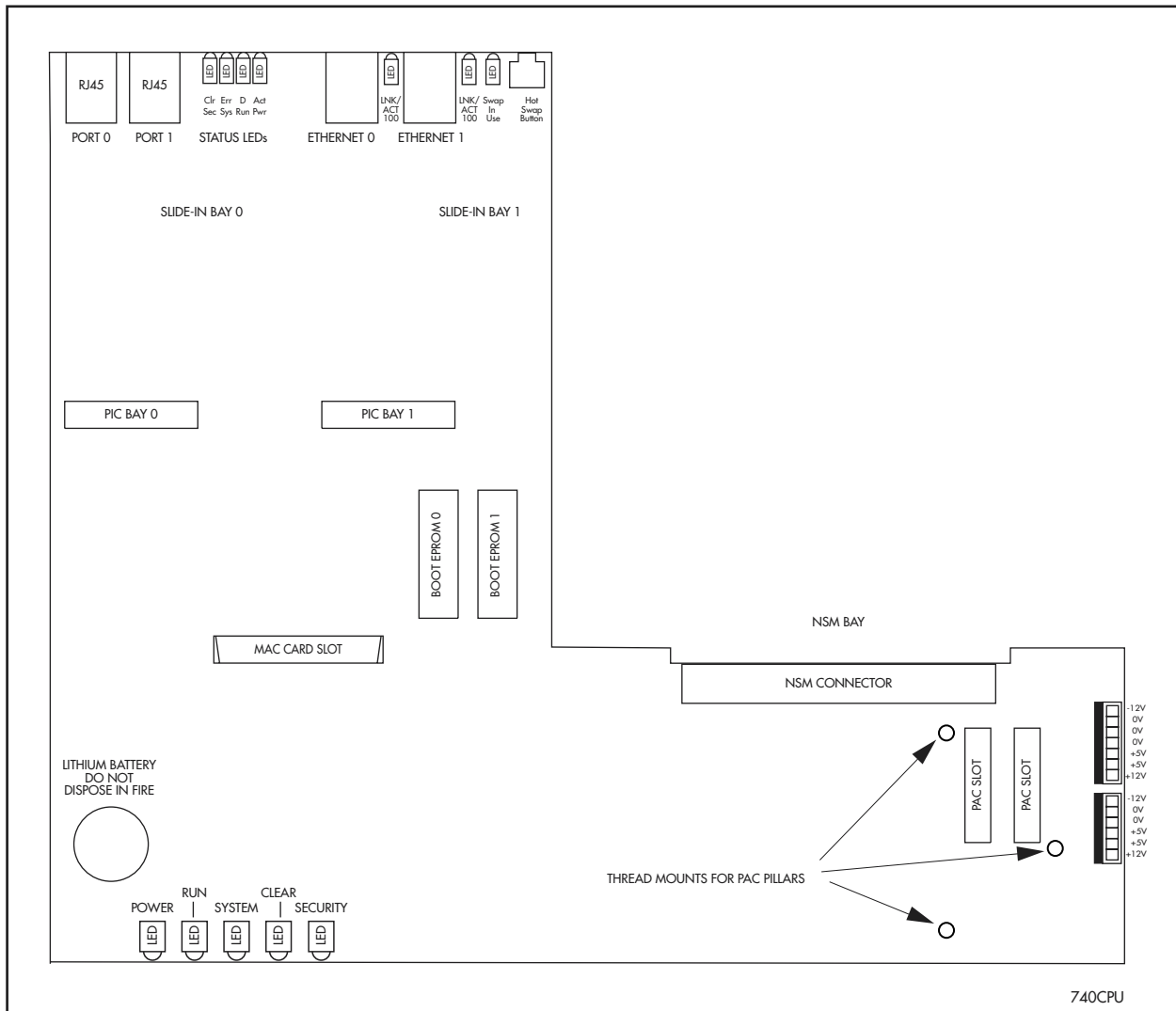

## 6. Insert the PAC.

Position the PAC over the PAC slot on the router base card, making sure that the support pillars located on the router base card are aligned with the holes provided on the PAC. This ensures that the connector on the PAC is correctly aligned with the slot on the router base card.

Press the connector firmly into place. Secure the PAC to its three pillars using the fasteners supplied.

Figure 67 on page 106 shows the PAC slot on an AR740 base board.

## 7. Replace the router's lid and the power cord.

Secure the router's lid, then reconnect the power cord. If you disconnected an RPS supply, reconnect it now.

## 8. If you disconnected interface cables to install the PAC, reconnect them.

The PAC is now ready to test.

## Testing a PAC

There are several ways to check that the PAC is installed and operating correctly. First, check that the router has recognised the card. Turn on the router and enter the command:

```
SHOW SYSTEM
```

to display system information (Figure 64 on page 103).

The first part of the display shows details of the cards installed in the router. There should be at least two entries, one for the router base card and one for the PAC. Both the serial number and the part name should be displayed.

If there is no entry for the PAC then the router's boot process has not correctly detected the PAC's presence. The most likely cause is that the PAC is not correctly plugged into the slot on the router's base board. Repeat the installation process, paying particular attention to Step 6.

Use the SHOW SYSTEM command again, and if the display is still not correct, contact your authorised Allied Telesyn distributor or reseller.



---

*If you have any difficulty with the PAC at any time, contact your authorised Allied Telesyn distributor or reseller and quote the serial numbers of both the base card on the router and the PAC. The serial numbers and revision details can be read using the SHOW SYSTEM command. It's a good idea to record this information for later reference.*

---

**Figure 68: Example output from the SHOW SYSTEM command for an AR740 router with an AT-AR061 ECPAC installed.**

```

Router System Status                               Time 09:28:27 Date
15-Jun-2001.
Board      ID   Bay Board Name                               Rev   Serial number
-----
Base      78   AR740                               M1-15 46689862
PIC       40   0   AT-AR022-00 PIC Eth                         M4-0  40239075
PIC      152   1   AT-AR026-00 PIC 10/100 Eth                  P1-0  40846780
PAC      153   AR061 ECPAC                          P3-16 6845158
-----
Memory -   DRAM : 16384 kB   FLASH :  4096 kB
-----
SysDescription
CentreCOM AR740 version 2.2.2-00 18-May-2001
SysContact

SysLocation

SysName

SysDistName

SysUpTime
6490 ( 00:01:04 )
Software Version: 2.2.2-00 18-May-2001
Release Version : 2.2.2-00 18-May-2001
Release built   : Jun 14 2001 at 00:55:17
Patch Installed : NONE
Territory      : japan
Help File      : help.hlp

Main PSU       : ***OFF***   Main Fan       : ***OFF***
RPS Monitor    : Off

Boot configuration file: boot.cfg (exists)
Current configuration: boot.cfg
Security Mode   : Disabled

Patch files
Name           Device   Size   Version
-----
52202tst.paz  flash   6036   2.0-1
52203pac.paz  flash  10636   2.0-1
-----

```

Next, check the PAC's status using the command:

```
SHOW LOG
```

to display a log of PAC events. A typical display is shown in Figure 65 on page 103.

**Figure 69: Example output from the SHOW LOG command for an AR740 router with an AT-AR061 ECPAC card installed.**

| Date/Time   | S | Mod  | Type | SType | Message   |
|-------------|---|------|------|-------|---|
| 15 00:05:50 | 4 | ENCO | ENCO | PAC   | 7751 Found. Initialisation started                  |
| 15 00:05:50 | 4 | ENCO | ENCO | PAC   | 7751 Initialisation Successful                      |
| 15 00:05:50 | 7 | SYS  | REST | NORM  | Router startup, ver 2.2.2-00, 18-May-2001,<br>Clock |
|             |   |      |      |       | Log: 00:04:40 on 15-Jun-2001                        |
| 15 00:05:53 | 3 | USER | USER | 00011 | manager login failed on port0                       |
| 15 00:05:58 | 3 | USER | USER | LON   | manager login on port0                              |
| 15 00:05:59 | 3 | CH   | MSG  | WARN  | No patches found                                    |



*If any PAC tests fail, check that the PAC is correctly installed in its slot and repeat the tests. Contact your authorised Allied Telesyn distributor or reseller if the PAC does not operate correctly.*

Once the PAC is operating, its functionality can be tested either by using the Test Facility software, which is built into the router, or by configuring a module to use the PAC. For more information about configuring interfaces, see the “Compression and Encryption Services” chapter of your router’s Software Reference.

### Using the Test Facility to Verify Operation

The built-in Test Facility software is the easiest way to verify a PAC’s operation.



*See the Test Facility chapter of your router’s Software Reference for more information about the Test Facility.*

To run the Test Facility for a PAC, use the command:

```
ENABLE TEST INTERFACE=PAC
```

The test will run for 4 minutes. To view the results of the test at any time, use the command:

```
SHOW TEST
```

Figure 70 on page 110 shows a typical output. The status of the test will be shown in the right-hand column. For further information on the meanings of the other figures, see the “Test Facility” chapter of your router’s Software Reference.

**Figure 70: Example output from the SHOW TEST command for an AR740 router with an AT-AR061 ECPAC installed.**

```

Router System Status                               Time 09:28:27 Date
15-Jun-2001.
Board      ID   Bay Board Name                               Rev   Serial number
-----
Base       78           AR740                               M1-15 46689862
PIC        40   0   AT-AR022-00 PIC Eth                         M4-0  40239075
PIC        152  1   AT-AR026-00 PIC 10/100 Eth                   P1-0  40846780
PAC        153           AR061 ECPAC                             P3-16 6845158
-----
Memory -   DRAM : 16384 kB   FLASH :  4096 kB
-----
SysDescription
CentreCOM AR740 version 2.2.2-00 18-May-2001
SysContact

SysLocation

SysName

SysDistName

SysUpTime
6490 ( 00:01:04 )
Software Version: 2.2.2-00 18-May-2001
Release Version : 2.2.2-00 18-May-2001
Release built   : Jun 14 2001 at 00:55:17
Patch Installed : NONE
Territory       : japan
Help File       : help.hlp

Main PSU        : ***OFF***   Main Fan          : ***OFF***
RPS Monitor     : Off

Boot configuration file: boot.cfg (exists)
Current configuration: boot.cfg
Security Mode    : Disabled

Patch files
Name            Device    Size    Version
-----
52202tst.paz    flash    6036    2.0-1
52203pac.paz    flash    10636   2.0-1
-----

```

If you are unsure about running the Test Facility, or have difficulty evaluating the results then contact your authorised Allied Telesyn distributor or reseller.

## Installing a Flash SIMM

Early models of AT-AR720 routers can be upgraded from the factory default 4MB of flash memory to 8MB of flash memory by installing a 4MB 80-way *Single Inline Memory Module* (SIMM) stick.



*SIMMs should only be installed by authorised service personnel. Unauthorised opening of the router lid may cause danger of injury from electric shock, damage to the router, and invalidation of the product warranty.*

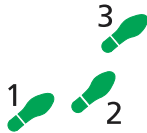

### Before installing a flash SIMM:

1. **Check that you have the correct tools and equipment.**

You will need a medium-sized posidrive screwdriver.

2. **Avoid injury by working in a safe environment.**

The work space should be free of hazards, and there should be sufficient room to lay out the router, the flash SIMM stick, and the tools.

3. **Unpack the flash SIMM stick in an antistatic environment.**



*Flash memory, like most electronic devices, is highly sensitive to electrostatic damage. This can be particularly acute in the dry atmosphere of computer rooms and offices. Before commencing work, ensure that you have an approved antistatic wrist strap connected to an earthing point. Wear the strap at all times during this procedure. Failure to follow the correct antistatic procedures may result in damage to the router or the flash SIMM stick. If you have any queries about antistatic procedures, contact your authorised Allied Telesyn distributor or reseller.*

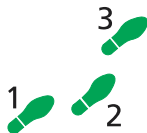

### To install a flash SIMM:

1. **Turn off the router and remove the mains and, if connected, RPS power cord.**



*Do not take risks with mains electricity. Although the router is fully shielded internally, the power should always be removed to reduce the risk of electrical shock. Always disconnect the power cord and, if connected, the RPS power cord before attempting to remove the lid of the router.*

2. **Remove the router lid.**

The router lid is secured by posidrive screws. Remove the screws and lift the lid off the chassis.

The router may need to be removed from any racking system before the lid can be removed.

3. **Insert the new SIMM.**

The SIMM stick is polarised by a notch located at one end of the stick and a half circular notch located in the middle of the stick. When the stick is installed correctly into its socket, the half circular notch will align with a bulge in the socket.

Insert the new stick into the SIMM socket at an angle of about 60 degrees, ensuring it is inserted fully into the socket along its entire length. Rotate

the stick down onto the retaining latches and ensure the latches hold the stick firmly in place.

**4. Replace the router lid and the power cord.**

Secure the router’s lid, then reconnect the power cord. If you disconnected an RPS supply, reconnect it now.

**AT-AR720 Dip Switch Settings**

A DIP switch is used to change functional characteristics of the base CPU card. Figure 71 on page 112 shows the DIP switch’s location on the AT-AR720’s base CPU card. DIP switch functions are shown in Table 40 on page 113.



*All DIP switches should be left in the factory default positions unless advised by your distributor or reseller that they need to be changed. Jumpers should only be replaced by authorised service personnel. Unauthorised opening of the router lid may cause danger of injury from electric shock, damage to the router, and invalidation of the product warranty.*

**Figure 71: Location of main components, jumpers and DIP switch on the AT-AR720 base CPU card.**

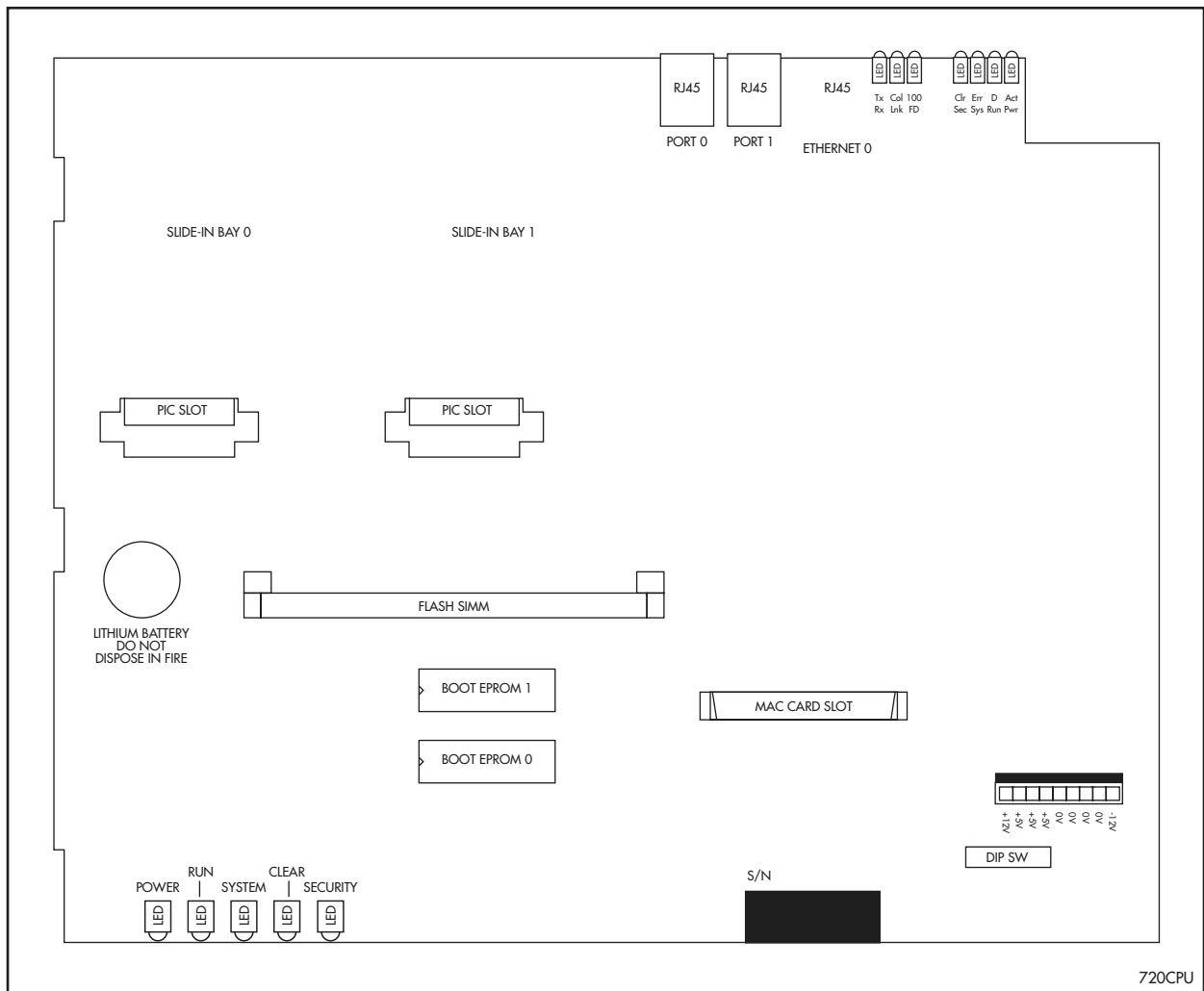

**Table 40: Functions of the DIP switch on the AT-AR720 base CPU card.**

| DIP Switch | Function                               | Default |
|------------|--|---------|
| SW1-1      | Reserved (should be OFF)               | OFF     |
| SW1-2      | Enable startup messages (ON=enable)    | ON      |
| SW1-3      | Reserved (should be OFF)               | OFF     |
| SW1-4      | Enable show cycles (ON=enable)         | OFF     |
| SW1-5      | Disable data cache (ON=disable)        | OFF     |
| SW1-6      | Disable instruction cache (ON=disable) | OFF     |
| SW1-7      | Enable diagnostic mode (ON=enable)     | OFF     |
| SW1-8      | Reserved (should be OFF)               | OFF     |

## Diagnostics

The router software includes a set of diagnostic programs. These programs perform basic level checks of all system components. They do not run in conjunction with the normal operating code, and require that the system be totally dedicated to their use. A detailed knowledge of the way your router hardware functions is necessary if diagnostics are to be used effectively.

---

*Diagnostic mode is only to be used by authorised service personnel. Unauthorised use of diagnostic mode may cause the router to cease functioning, may invalidate the product warranty, and may be a breach of the product licence agreement.*

---



---

*The router will not function as a router if diagnostic mode is running.*

---



---

*Diagnostics will not perform checks on AT-AR026 PICs.*

---

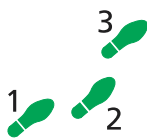

### To enable diagnostics mode:

#### 1. Connect a terminal to the console port.

Connect a terminal to the console port (port 0) on the router's rear panel, and set the terminal communications parameters to:

- 9600bps
- 8 data bits
- 1 stop bit
- No parity
- Hardware flow control.

#### 2. Restart the router.

Restart the router, either by switching it off and on again using the power switch on the rear panel, or by using the terminal to login and enter the command:

```
RESTART REBOOT
```

### 3. Enable diagnostics mode during start-up.

During the router start-up process, at the prompt:

```
Force EPROM download (Y)?
```

press [Ctrl/D] on the terminal to enter diagnostics mode. A banner page will be displayed on the terminal (Figure 72 on page 114). This can be used to check that the terminal is correctly connected.

**Figure 72: AR router diagnostics banner page.**

```
* * * Diagnostic Mode * * *

version 06-Mar-95

Main Menu:
 1. Full RAM test
 2. ROM checksum test
 3. Battery backed RAM battery test
 4. Battery backed RAM test
 5. Watchdog test
 6. Full Flash Test
 7. Totally Erase FLASH
 P. Go to Probe

R Enter selection ==>
```

To run a diagnostic program, enter the corresponding letter or number. There are several sub-menus to cover all the different options. Table 41 on page 114 lists the keys that control the basic operation of the diagnostics.

**Table 41: Basic commands for running diagnostics.**

| Key | Function  |
|-----|---|
| Q   | Quits any running tests and displays the banner page. |
| S   | Prints a summary of test results so far.              |

Diagnostics are designed to be used with all models of the router, and therefore some instances of particular tests will not be appropriate for some models. A reasonable level of understanding of the system structure is needed to operate diagnostics and interpret the results. Diagnostics only require the base CPU board to be installed in the system.

To restore the router to normal operation, perform a restart by switching its power switch (rear panel) OFF and ON.



*This manual is not intended as a guide to diagnostics. Diagnostics are designed to be run by service personnel only. For more information, contact your authorised Allied Telesyn distributor or reseller.*



*Running the battery-backed RAM test, Full Flash test, or Totally Erase Flash option will cause important system files to be deleted. These will need to be reinstalled before the router can function normally.*

## Replacing Boot EPROMs

AR300 Series routers have one boot EPROM and AR720/AR740 routers have two boot EPROMs. Boot EPROMs contain bootstrap code, which loads the main code from a software release file in flash memory. In rare circumstances the boot EPROM(s) may need to be changed. AR725 and AR745 routers do not have boot EPROMs.



---

*Boot EPROMs do not need to be replaced, except in rare circumstances. Boot EPROMs should only be replaced by authorised service personnel. Contact your authorised Allied Telesyn distributor or reseller. Unauthorised opening of the router lid may expose you to live components and a risk of injury from electric shock, it may also damage the router and invalidate the product warranty.*

---

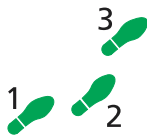

### To change the boot EPROMs:

1. **Check that you have the correct tools and equipment available.**

You will need a medium-sized posidrive screwdriver and an EPROM extraction tool (or a small flat bladed screwdriver). In addition, adequate antistatic precautions must be observed.



---

*EPROMs, like most electronic equipment, are highly sensitive to electrostatic damage. This can be particularly acute in the dry atmosphere normally associated with computer rooms and typical offices. Before commencing work, ensure that you have used an approved antistatic wrist strap to discharge any buildup of static electricity. Wear the strap at all times during the following procedure.*

---

2. **Avoid injury by working in a safe environment.**

The workspace should be free of hazards, and there should be sufficient room to lay out the router, the expansion card and the tools.

3. **Turn OFF the router and remove the mains power cord.**



---

*Do not take risks with mains electricity. Do not attempt to remove the lid of a router unless the power cord has been removed from the router.*

---

4. **Remove the router lid.**

The router lid is secured by posidrive screws. Remove the screws and lift the lid off the chassis.

The router may need to be removed from any racking system before the lid can be removed.

5. **Remove any MAC card (AR300 Series only).**

On AR300 Series routers, if a MAC card is installed then it must be removed to gain access to the boot EPROM. See “Installing a MAC” on page A-69 for instructions.

6. **Remove the existing boot EPROMs.**

The boot EPROM(s) should now be visible on the CPU board. Table 42 on page 116 lists diagrams showing the location of boot EPROMs on each

router base CPU board. Remove the boot EPROMs using the extraction tool. Alternatively, a small flat-bladed screwdriver can be used. If so, gently lever each end of a particular boot EPROM a few millimetres at a time until it comes free.

**Table 42: Diagrams showing the locations of EPROMs for each router model.**

| Router Model | Diagram showing Boot EPROM location |
|--------------|-------------------------------------|
| AT-AR300L(S) |                                     |
| AT-AR300(S)  | Figure 9 on page 27                 |
| AT-AR310(S)  |                                     |
| AT-AR320     |                                     |
| AT-AR330     | Figure 10 on page 28                |
| AT-AR350     | Figure 11 on page 29                |
| AT-AR370(S)  | Figure 12 on page 30                |
| AT-AR370(U)  | Figure 13 on page 31                |
| AT-AR390     |                                     |
| AT-AR395     | Figure 14 on page 32                |
| AT-AR720     | Figure 71 on page 112               |
| AT-AR740     | Figure 22 on page 51                |

#### 7. Insert the new boot EPROMs.

Insert the new boot EPROMs one at a time, using as a reference the location number and the relevant location diagram. Check that the boot EPROMs are firmly seated.



*Install the boot EPROMs the correct way up! Failure to do so will almost certainly destroy them. The 'top' end of the EPROM has a notch. This should be positioned so that the notched end of the EPROM is orientated as shown in the relevant location diagram.*

#### 8. Replace any MAC card (AR300 Series only).

Replace any MAC card removed in step 5. See "Installing a MAC" on page 100 for instructions.

#### 9. Replace the router lid and the power cord.

Replace the router lid and secure it with the four posidrive screws. Connect the power cord, and switch the router ON.

#### 10. Check that the router is operating correctly.

Check that the router boots up correctly. See "Router Start-up" on page 10 for a list of start-up messages. Verify that the new software version is installed by typing the command:

```
SHOW INSTALL
```

which will produce a display like that shown in Figure 73 on page 117. The boot EPROM software release number is shown in the "Default" field. Check that it is correct.

**Figure 73: Example output from the SHOW INSTALL command.**

```

Install      Release                               Patch
-----
Temporary   -                                           -
Preferred   flash:load\8-181.rez                     -
Default     EPROM (8-1.8.1)                          -
-----

Current install
-----
Preferred   flash:load\8-181.rez                     -
-----

Install history
-----
No Temporary install selected
Preferred install selected
Preferred release successfully installed
-----

```

## Troubleshooting

If the router fails to reboot or functions incorrectly, then the most likely cause is that there is a problem with the way the boot EPROMs were installed. Repeat the procedure. Check that the boot EPROMs are in the correct locations and oriented correctly, using the relevant location diagram as a guide. Check for bent pins. These should be carefully straightened. Replace the boot EPROMs and complete the remaining steps.

If the router still fails to reboot, replace the new boot EPROMs with the original set and contact your distributor or reseller.

## Lithium Battery Replacement

The following routers have a replaceable lithium battery:

- AR410
- AR410S
- AR450S
- AR720
- AR725
- AR740
- AR745

If replacing the battery, use a 3V lithium button cell, type CR2032 or equivalent.

The battery should be replaced if:

- The router has been in storage for more than two years
- The router has only been powered up intermittently over a two year period
- The message "ERROR: BBR Battery low" is displayed
- The router loses its time setting

- A log file displays “NVS corrupted”
- An SNMP trap displays “NVS is reset”
- The router’s configuration is lost after a power cycle



*Batteries should only be replaced by authorised service personnel. Unauthorised opening of the router lid may cause danger of injury from electric shock, damage to the router, and invalidation of the product warranty.*

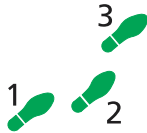

#### Before replacing a lithium battery:

1. **Check that you have the correct tools and equipment.**

You will need a medium-sized posidrive screwdriver and a battery (3V lithium button cell, type CR2032 or equivalent).

2. **Avoid injury by working in a safe environment.**

The workspace should be free of hazards, and there should be sufficient room to lay out the router and tools.

3. **Work in an antistatic environment.**



*Do not attempt to replace a battery without observing correct antistatic procedures. Failure to do so may damage the router. If you are unsure what the correct procedures are, contact your authorised Allied Telesyn distributor or reseller.*

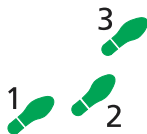

#### To replace a lithium battery:

1. **If connected, disconnect the router’s RPS power supply.**
2. **Power off the router and remove the mains power cord.**



*Before removing the router’s lid, the power cord and, if connected, RPS power cord should be disconnected to reduce risk of electrical shock.*

3. **Remove all interface cables.**
4. **Remove the router lid.**

The router may need to be removed from any racking system before the lid can be removed.

The router lid is secured by posidrive screws. Remove the screws and lift the lid off the chassis.

5. **Remove the existing battery.**

The diagrams listed in Table 43 on page 119 show the battery location for each router model.



*Do not short circuit the battery as it may cause burns.*



*Do not disassemble, apply excessive pressure to, or deform the battery.*



*Do not heat the battery or dispose of it in a fire or furnace as the battery may burst or release toxic materials.*



*Dispose of used batteries according to the battery manufacturer's instructions. Ultimate disposal of lithium batteries must be handled in accordance with all applicable international, national, and local laws and regulations. Dispose of the battery in an environmentally friendly way.*

**Table 43: Lithium battery location diagrams.**

| Router model | Diagram showing location of lithium battery |
|--------------|---|
| AR410        | Figure 15 on page 35                        |
| AR410S       | Figure 15 on page 35                        |
| AR450S       | Figure 18 on page 40                        |
| AR720        | Figure 71 on page 112                       |
| AR725        | Figure 71 on page 112                       |
| AR740        | Figure 67 on page 106                       |
| AR745        | Figure 25 on page 57                        |

#### 6. Insert the new battery.

Carefully place the battery in the battery socket, ensuring it is firmly seated and held in place by the clip.

Keep handling of the battery to a minimum, and keep the battery as clean as possible.



*Replace the battery only with the same or equivalent type recommended by the battery manufacturer.*



*Avoid surface or grease contamination of the battery's surface. Clean the battery if necessary.*

#### 7. Replace the router lid and the power cord.

Secure the router's lid, then reconnect the power cord. If you disconnected an RPS supply or interface cables, reconnect them now.

#### 8. Set the real-time clock's date and time.

Power up the router, log in and set the date and time.

To set date and time, use the command:

```
SET [TIME=time] [DATE=date]
```

Where *time* is the time in 24 hour format (hh:mm:ss) and *date* is the date in one of the formats dd-mm-yy, d-mmm-yyyy, dd-mmm-yy or dd-mmm-yyyy.

The battery is now ready to test.

### 9. Test the battery.

Log out and power off the router. With the router powered off, wait approximately two minutes, then power up the router and log in.

If the battery is good and is installed correctly, the real-time clock's time and date will be consistent with the time and date set in the previous step.

To view the clock's time and date, enter:

```
SHOW TIME
```

### Troubleshooting battery replacement.

If the real-time clock date and time are still lost after a power cycle, follow these steps:

1. Check that the battery is of the correct type.
2. Check that the battery is correctly installed; repeat the battery installation procedure.
3. If the installation fails a second time, try using another battery.
4. If installation of a second battery fails, contact your authorised Allied Telesyn distributor or reseller.

## Contacting Us

---

With locations covering all of the established markets in North America, Latin America and Europe, Allied Telesyn provides localized sales and technical support worldwide. To find our representative nearest you, visit Allied Telesyn on the web at: <http://www.alliedtelesyn.com>.