

NETWORK SERVICE MODULE

HARDWARE REFERENCE

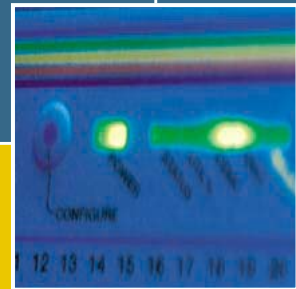
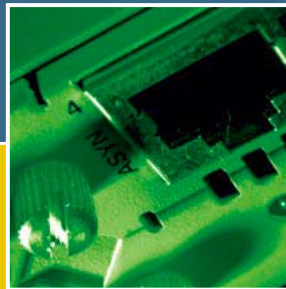
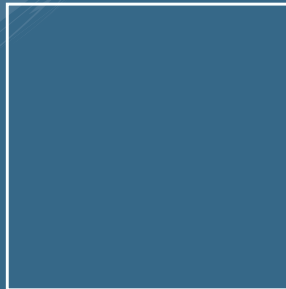

Network Service Module Hardware Reference
Document Number C613-03022-00 REV F.

Copyright © 1999-2002 Allied Telesyn International, Corp.
19800 North Creek Parkway, Suite 200, Bothell, WA 98011, USA.

All rights reserved. No part of this publication may be reproduced without prior written permission from Allied Telesyn.

Allied Telesyn International, Corp. reserves the right to make changes in specifications and other information contained in this document without prior written notice. The information provided herein is subject to change without notice. In no event shall Allied Telesyn be liable for any incidental, special, indirect, or consequential damages whatsoever, including but not limited to lost profits, arising out of or related to this manual or the information contained herein, even if Allied Telesyn has been advised of, known, or should have known, the possibility of such damages.

All trademarks are the property of their respective owners.

Contents

| | |
|--|----|
| Models Covered By This Reference | 4 |
| Why You Should Read This Reference | 4 |
| Where To Find More Information | 4 |
| Compatible Base Units For NSMs | 5 |
| What NSMs Do | 5 |
| Operating Environment And Regulatory Standards | 6 |
| Environmental Conditions | 6 |
| Regulatory Standards | 6 |
| AT-AR040 NSM | 7 |
| AT-AR041 and AT-AR042 NSMs | 8 |
| Basic Rate ISDN Interfaces | 8 |
| ISDN S/T Interface Cables | 10 |
| Testing a BRI NSM | 10 |
| AT-AR048 NSM | 12 |
| DS3 Interface | 13 |
| DS3 Interface Cables | 13 |
| Testing a DS3 NSM | 13 |
| Hot Swapping | 15 |
| Hot Swapping the AR040 NSM with PICs | 15 |
| How to Hot Swap an NSM | 15 |
| Behaviour of Hot Swapped Interfaces | 17 |
| Troubleshooting | 19 |
| LEDs and What They Mean | 19 |
| Contacting Us | 23 |

Models Covered By This Reference

This Hardware Reference includes information on the following models:

- AT-AR040
- AT-AR041
- AT-AR042
- AT-AR048

The latest Hardware Reference can be found at www.alliedtelesyn.co.nz/support/support.html.

Why You Should Read This Reference

This Reference has been developed to familiarise you with the hardware features of Network Service Modules (NSMs). The Reference provides information that will assist you with the process of managing and servicing an NSM. For information about installing an NSM, see the *Network Service Module Quick Install Guide*.

The Reference also introduces Port Interface Card (PIC) expansion options. Detailed information on PICs can be found in the *Port Interface Card Hardware Reference*. This Reference and the PIC Reference can be found on the CD-ROM bundled with every switch or router, or at www.alliedtelesyn.co.nz/support/support.html.



This Reference does not cover software configuration or physical installation procedures. For information on software, refer to the Software Reference for your switch or router. For information on installing an NSM, refer to the Network Service Module Quick Install Guide. These guides and references can be found on the CD-ROM bundled with NSM-compatible switches or routers, or at www.alliedtelesyn.co.nz/support/support.html.

Where To Find More Information

There are several sources of further information:

- The *Network Service Module Quick Install Guide*, which outlines the procedure for installing NSMs.
- The Hardware and Software References for your switch or router, which provide information on related hardware and software features.
- The *Port Interface Card Quick Install Guide*, which outlines the procedure for installing PICs; and the *Port Interface Card Hardware Reference*, which provides detailed information on PICs.

All of these documents can be found on the CD-ROM bundled with your switch or router, or at www.alliedtelesyn.co.nz/support/support.html.

Compatible Base Units For NSMs

Table 1 on page 5 lists NSM-ready products and indicates which NSM model can be used in each.

Table 1: Compatibility of NSMs models.

| Family | Model(s) | AR040 | AR041 & AR042 | AR048 ¹ |
|--------------------------------|----------------------------|-------|---------------|--------------------|
| Rapier | Rapier 8/8 (MT & SC) | ✓ | ✓ | |
| | Rapier 16F-FX (MT-RJ & SC) | ✓ | ✓ | |
| | Rapier 24 | ✓ | ✓ | |
| Rapier <i>i</i> | Rapier 24 <i>i</i> | ✓ | ✓ | ✓ |
| AR800 Modular Switching Router | AR816F-FX (MT-RJ & SC) | ✓ | ✓ | |
| | AR824 | ✓ | ✓ | |
| AR Routers | AR740 | ✓ | ✓ | |
| | AR745 | ✓ | ✓ | |

1. Maximum DS3 packet forwarding rates are achieved only when the AT-AR048 is installed in a Rapier 24*i* whose serial number ends with the letter N or higher. If maximum DS3 performance is not required, the AT-AR048 can be installed in any Rapier 24*i* whose serial number ends in J, K, L, or M. The serial number can be found on the underside of the switch (see Figure1 on page5).

Figure 1: Serial number label, as found on underside of switch.

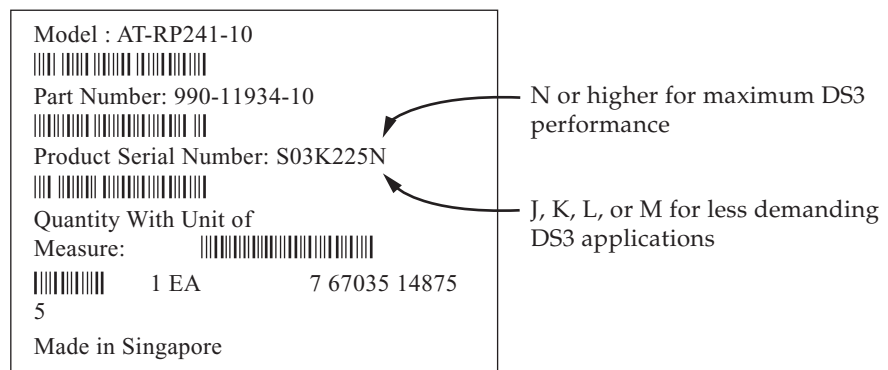

What NSMs Do

NSMs are expansion options for those switch and router models that have an NSM bay. NSMs slot into a base-unit switch or router and either directly provide additional WAN interfaces, or provide multiple slots where PICs (with WAN interfaces) can be added.

Operating Environment And Regulatory Standards

This section provides an overview of the recommended operating environment for NSMs, as well as regulatory and conformance standards. Detailed safety and conformance information can be found in the Safety and Statutory Information booklet for your switch or router.

Environmental Conditions

- Operating temperature range: 0 to 40° C (32 to 104° F)
- Storage temperature range: -25 to 70° C (-13 to 158° F)
- Relative humidity range: 5 to 95% non-condensing

Regulatory Standards

AT-AR040

- Listing: UL, cUL, TUV
- Safety: UL 60950, CAN/CSA-C22.2 NO. 60950-00, EN60950, AS/NZS3260 / TS001
- EMC: Radiated: EN55022 class A, FCC class A, VCCI class A, AS/NZS CISPR22 class A
- Immunity: EN55024

AT-AR041 and AT-AR042

- Listing: UL, cUL, TUV
- Safety: EN60950, AS/NZS3260 / TS001
- EMC: Radiated: EN55022 class A, AS/NZS CISPR22 class A
- Immunity: EN55024
- Network interface: TBR3, ACA TS031, iDA ISDN 1

AT-AR048

- Listing UL, cUL
- Safety: UL60950, CAN/CSA-C22.2 No. 60950-00
- EMC: Radiated: FCC Part 15 class A, IC-03 class A
- Network interface: ANSI T1.102, ANSI T1.404, ANSI T1.107, ANSI T1.231

AT-AR040 NSM

The AT-AR040 provides four Port Interface Card (PIC) slots (Figure 2 on page 7).

Figure 2: AT-AR040 NSM with three PICs.

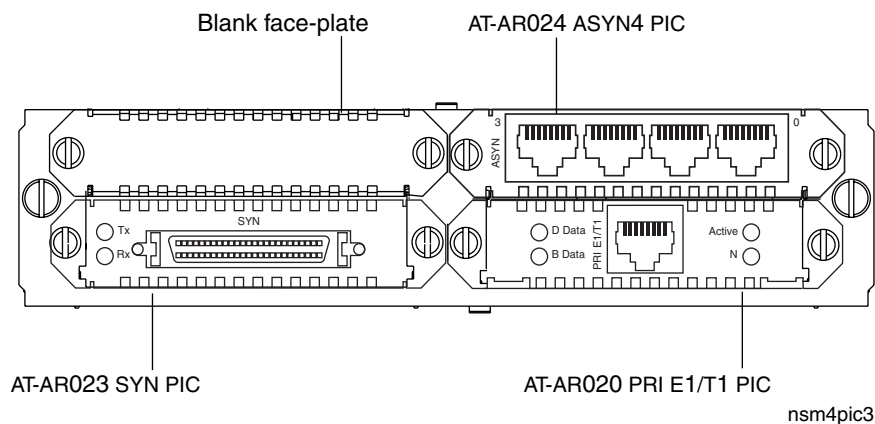

This NSM supports combinations of the following PICs (with a maximum of two E1/T1/PRI cards):

- AT-AR020 PRI E1/T1 (Primary Rate ISDN)¹
- AT-AR021 (S) BRI-S/T (Basic Rate ISDN S/T)
- AT-AR021 (U) BRI-U (Basic Rate ISDN U)
- AT-AR023 SYN (Synchronous RS-232/X21/V35 DCE/DTE to 2Mps)
- AT-AR024 ASYN4 (Four Asynchronous ports)

1. Up to two PRI E1/T1 PIC cards (AT-AR020) can be installed in the NSM. A maximum of 32 TDM slots are allowed in each NSM row, and the maximum aggregate bandwidth for each row is 2.6 Mbps. If two PRI E1/T1 PICs are installed, the first must be in the lower row (bay 0 or 1), and the second must be in the upper row (bay 2 or 3). If an AT-AR020 E1/T1 PRI PIC is installed in one of the rows in the NSM and operating in E1 mode, then this row cannot also have an AT-AR021(S) BRI-S/T PIC or an AT-AR021(U) BRI-U PIC installed.



AT-AR022 ETH PICs and AT-AR026 4ETH PICs are not recommended for use in the NSM PIC bays, as performance of these interfaces is likely to be reduced and packet loss may occur.

Interface numbering for AT-AR040 NSMs

Interface numbering for each interface type (e.g., BRI, PRI, SYN, ETH, PORT) begins at 0 on the base switch or router and continues until all interfaces of that type on the base unit are numbered. For AR700 Series routers, the numbering then continues with the PIC interfaces installed directly in the router's PIC bays, starting at PIC bay 0. For switches and routers, the numbering then continues with the interfaces installed in the NSM, starting with NSM PIC bay 0, and ending with NSM PIC bay 3.

It is recommended that PICs be installed in the router's PIC bays and NSM's PIC bays in the above sequential order, so that interface numbering is not changed when a new PIC is installed.

AT-AR041 and AT-AR042 NSMs

The AT-AR041 NSM provides eight Basic Rate ISDN S/T WAN ports (Figure 3 on page 8), while the AT-AR042 NSM provides four Basic Rate ISDN S/T WAN ports (Figure 4 on page 8). In both cases the ports use RJ-45 connectors and provide TE interfaces. There are two status LEDs per port (Table 3 on page 20).



AT-AR041 and AT-AR042 NSMs support point-to-point links. Point to multi-point links are not supported.

Figure 3: AT-AR041 NSM.

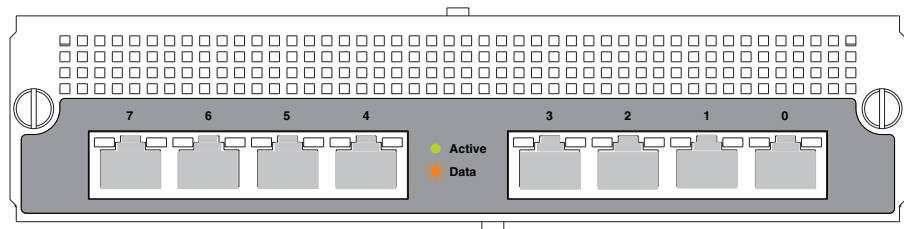
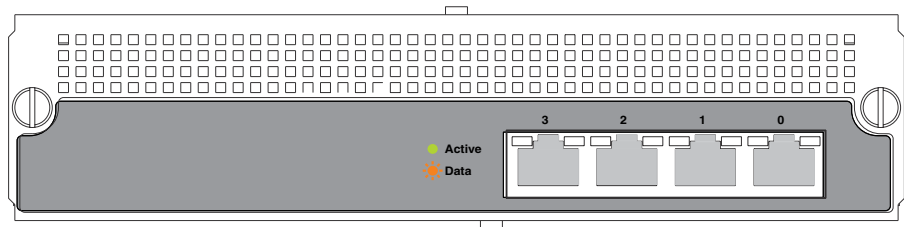

Figure 4: AT-AR042 NSM.



Basic Rate ISDN Interfaces

AT-AR041 and AT-AR042 NSMs provide Basic Rate ISDN (BRI S/T) interfaces, which support two 64kbit/s channels and one 16kbit/s D channel.

Both BRI NSMs support only TE mode. The switch or router should be configured as a TE for normal operation.

Board-mounted jumpers determine the interface termination. By default, the jumpers are set in the Terminated position (bridging terminals 2 and 3) when NSMs leave the factory (Figure 5 on page 9). To set the line pairs to Not Terminated, remove the jumper and replace it so that it bridges terminals 1 and 2. If the building wiring provides the correct termination for an ISDN TE-to-NT circuit, the jumper should be set in the Not Terminated position.

Figure 5: Location of jumpers on BRI NSMs.

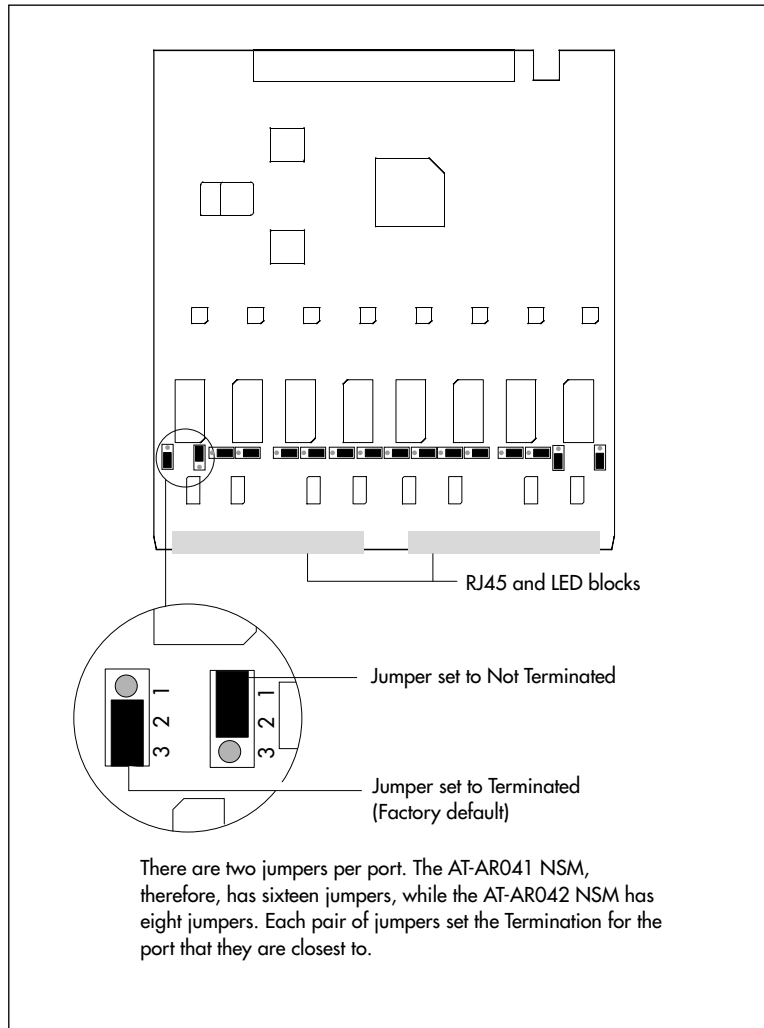

If the building wiring provides the correct termination for an ISDN TE-to-NT circuit, the jumper should be set in the NotTerminated position

The *Integrated Services Digital Network (ISDN)* chapter of the Software Reference for your switch or router has additional information on termination of ISDN lines.



If you are unsure whether to terminate the line or not, contact your ISDN service provider or your Authorized Allied Telesyn distributor or reseller.

The pinout of the BRI interface is shown in Table 2 on page 10.

Table 2: Pinout of the Basic Rate ISDN S/T interface .

| Pin | S/T Interface Functions |
|-----|-------------------------|
| 1 | - |
| 2 | - |
| 3 | TX+ |
| 4 | RX+ |
| 5 | RX- |
| 6 | TX- |
| 7 | - |
| 8 | - |

ISDN S/T Interface Cables

Figure 6 on page 10 shows how to wire a cable to connect a Basic Rate Interface (BRI) to the ISDN network terminating equipment (NT).

Figure 6: Pin wiring diagram for an ISDN Basic Rate straight-through Interface cable.

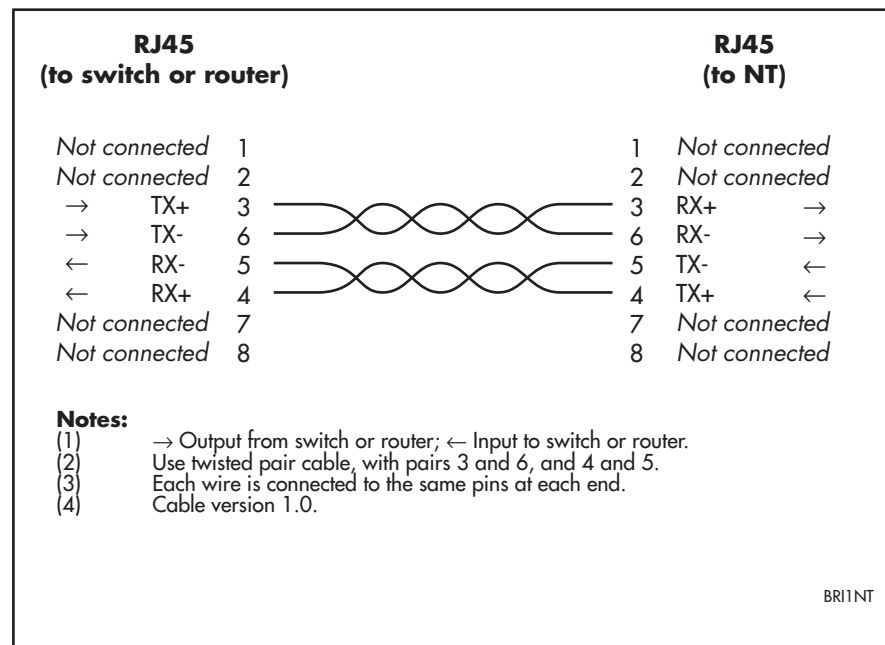

Testing a BRI NSM

A Test Facility is built into all switch and router software. The Test Facility is designed to test physical interfaces. Testing can be performed while the switch or router is operational, but any interfaces being tested are dedicated to the Test Facility. The Test Facility can be thought of as a specialised interface module like PPP or Frame Relay.

When testing BRI interfaces, the Test Facility is used in conjunction with a BRI S/T loopback plug. A loopback plug must be inserted into each interface that you wish to test. Figure 7 on page 11 shows how to wire the loopback plug.

Figure 7: BRI S/T loopback plug.

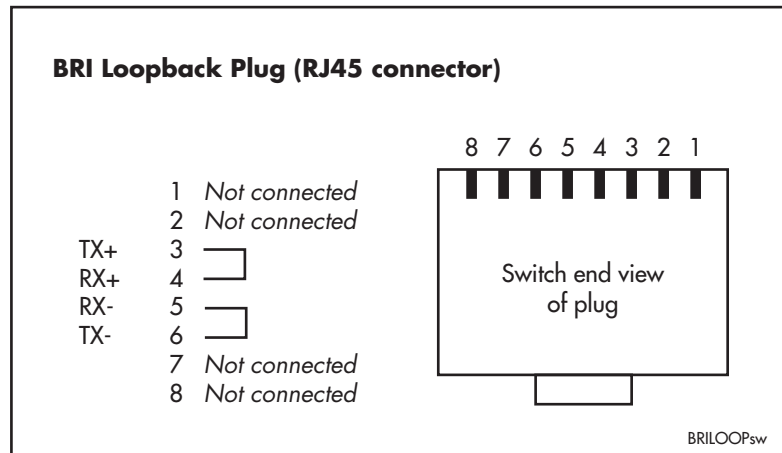

For more information on the Test Facility's operation, see the *Test Facility* chapter of the Software Reference for your switch or router.

To test a specific AT-AR041 or AT-AR042 interface, insert a BRI S/T loopback plug into the interface and enter the command:

```
ENABLE TEST INTERFACE=BRI n
```

where *n* is the interface number.

To test all AT-AR041 or AT-AR042 interfaces at once, insert BRI S/T loopback plugs into all NSM BRI interfaces and enter the command:

```
ENABLE TEST INTERFACE=EXPANSION
```

In both cases the tests will run for 4 minutes.

Test results are displayed with the command:

```
SHOW TEST
```

which produces a display like that shown in Figure 8 on page 12.

The status of the tests for each interface will be shown in the right-most column of the output. For more information on the meanings of the other figures, see the *Test Facility* chapter of the Software Reference for your switch or router.

If you are unsure about running the Test Facility, or have difficulty evaluating the results, contact your Authorized Allied Telesyn distributor or reseller.

Figure 8: Example output from the SHOW TEST command.

| Board | ID | Bay | Board Name | Rev | Serial number |
|-----------|----------|-------------------|----------------------|--------------------|---------------------|
| Base | 78 | | AR740 | M1-15 | 46625812 |
| PIC | 38 | 0 | AT-AR023-00 PIC Sync | M1-1 | 5918255 |
| NSM | 95 | | AT-AR041-00 NSM 8BRI | P1-3 | 46624968 |
| Interface | State | Result | Type | Duration (minutes) | Details Data(%OK) |
| Control | | | | | |
| eth0 | complete | good | trans | 0 | - - - |
| | | | TP | 1 | good(100.0) - |
| | | | ENDEC | 1 | good(100.0) - |
| | | | MAC | 1 | good(100.0) - |
| eth1 | complete | good | trans | 0 | - - - |
| | | | TP | 2 | good(100.0) - |
| | | | ENDEC | 0 | - - - |
| | | | MAC | 2 | good(100.0) - |
| syn0 | complete | * BAD | RS-232dte | 1 | good(100.0) BAD |
| | | | dce | 1 | good(100.0) BAD |
| | | | X.21 dte | 1 | good(100.0) BAD |
| | | | dce | 1 | good(100.0) BAD |
| | | | V.35 dte | 1 | good(100.0) BAD |
| | | | dce | 1 | good(100.0) BAD |
| asyn0 | complete | check this screen | - | 4 | - - - |
| asyn1 | complete | good | - | 4 | good(100.0) good |
| BRI0 | complete | good | - | 4 | good(100.0) - |
| BRI1 | complete | good | - | 4 | good(100.0) - |
| BRI2 | complete | good | - | 4 | good(100.0) - |
| BRI3 | complete | good | - | 4 | good(100.0) - |
| BRI4 | complete | good | - | 4 | good(100.0) - |
| BRI5 | complete | good | - | 4 | good(100.0) - |
| BRI6 | complete | good | - | 4 | good(100.0) - |
| BRI7 | complete | good | - | 4 | good(100.0) - |

For more complete testing, connect the BRI interface to an external ISDN test device and use the ENABLE BRI CTEST command and the DISABLE BRI CTEST command from the *Integrated Services Digital Network (ISDN)* chapter (of the Software Reference for your switch or router). This test will execute conformance loopback tests and generate packets.



If a test fails, please contact your Authorised Allied Telesyn distributor or reseller.

AT-AR048 NSM

The AR048 NSM provides a single unchannelised DS3 interface with two BNC connectors (transmit and receive). Figure 9 on page 13 shows the NSM's front panel.

To achieve maximum performance the NSM should be installed in a Rapier 24i whose serial number ends in the letter N or higher. If installed in a Rapier 24i whose serial number ends in the letter J, K, L, or M, the NSM will still operate,

but at a reduced rate. The NSM should not be installed in a switch whose serial number ends in the letter i or lower. The serial number is located on the switch's underside. For more information, including a sample serial number, see "Compatible Base Units For NSMs" on page 5.

Figure 9: AT-AR048 NSM

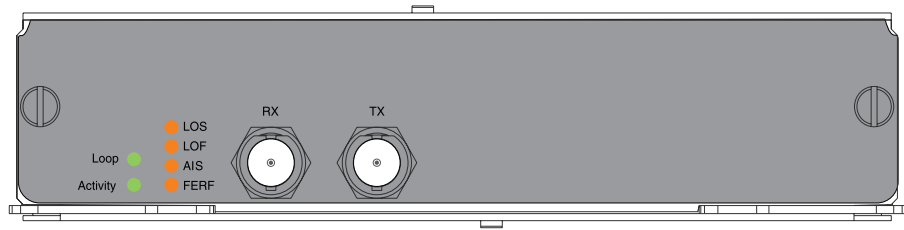

DS3 Interface

The AT-AR048 NSM provides one standards-based unchannelised DS3 interface. The interface has the following features:

- 44.736 Mbit/s interface rate, 44.210 Mbit/s payload data rate
- Separate transmit (Tx) and receive (Rx) BNC connectors
- 75-ohm impedance
- B3ZS line encoding
- Automatic compensation for lines up to 135m (450ft)
- Loop or internal timing
- C-bit framing
- Support for PPP and Frame Relay encapsulation

The interface meets the following specifications:

- ANSI T1.103, Digital Hierarchy - Synchronous DS3 Format
- ANSI T1.107, Digital Hierarchy - Formats
- ANSI T1.231, Digital Hierarchy - Layer 1 In-Service Digital
- RFC 2496 (DS3 MIB)

DS3 Interface Cables

Use 75-ohm RG59 coaxial cables with BNC connectors. Two cables are required, one for transmit and one for receive. Neither cable should exceed 135m (455ft) in length.

Testing a DS3 NSM

A Test Facility is built into all switch software. The Test Facility is designed to test physical interfaces. The interface is not available for network operations while the test is running.

For more information on the Test Facility's operation, see the *Test Facility* chapter of the Rapier Switch Software Reference.

To test an AR048 DS3 interface, connect a 75-ohm RG59 cable between the transmit and receive BNC connectors and enter:

```
ENABLE TEST INTERFACE=DS3n
```

where *n* is the interface number.

Alternatively, enter the command:

```
ENABLE TEST INTERFACE=EXPANSION
```

In both cases the tests will run for 4 minutes.

Test results are displayed with the command:

```
SHOW TEST
```

which produces a display like that shown in Figure 10 on page 14. A more detailed output (with frame counts) can be displayed with the command:

```
SHOW TEST INTERFACE COUNTER
```

which is shown in Figure 11 on page 14.

Figure 10: Example output from the SHOW TEST INTERFACE command for a DS3 interface.

| Board | ID | Bay | Board Name | Rev | Serial number |
|---------|-----|-----|---------------------|------|---------------|
| Base | 114 | | AT-RP24i Rapier 24i | M2-0 | 41376726 |
| NSM DS3 | 187 | | AT-AR048 NSM DS3 | M1-1 | 49986061 |

| Interface | State | Result | Type | Duration (minutes) | Details Data (%OK) | Control |
|-----------|----------|--------|------|--------------------|----------------------|---------|
| DS30 | complete | good | - | 4 | good (100.0) | |

Figure 11: Example output from the SHOW TEST INTERFACE COUNTER command for a DS3 interface.

| Board | ID | Bay | Board Name | Rev | Serial number |
|---------|-----|-----|---------------------|------|---------------|
| Base | 114 | | AT-RP24i Rapier 24i | M2-0 | 41376726 |
| NSM DS3 | 187 | | AT-AR048 NSM DS3 | M1-1 | 49986061 |

| Interface | State | Type | Duration (minutes) | Tx | RxTotal | RxGood | RxBad |
|-----------|----------|------|--------------------|-----------|-----------|-----------|-----------|
| DS30 | complete | - | 4 | 001045030 | 001045030 | 001045030 | 000000000 |

For more information on the meanings of the output, see the *Test Facility* chapter of the Rapier Switch Software Reference.

If you are unsure about running the Test Facility, or have difficulty evaluating the results, contact your Authorised Allied Telesyn distributor or reseller.



If a test fails, please contact your Authorised Allied Telesyn distributor or reseller.

Hot Swapping

Hot Swapping is the installation or removal of a component (such as an NSM) without powering down or restarting the switch or router.

NSMs can be hot swapped in and out of switches and routers that are running Software Release 2.3.1 or later.

To find out which software release your switch or router is running, use the command:

```
SHOW RELEASE
```



PICs can be swapped only if they are installed in an AR040 NSM. PICs installed in bays on base units (e.g., the chassis PIC bays on AR700 Series routers) cannot be hot swapped.

Hot Swapping the AR040 NSM with PICs

When an AR040 NSM with PIC cards is hot swapped out, and an identical combination of AR040 and PICs is hot swapped into the same bay, the software configurations for the PIC interfaces are preserved across the hot swap. In this case, modules configured to the PIC interfaces transfer to the newly swapped in interfaces.

When an AR040 NSM with PICs is hot swapped out and a different combination of AR040 and PICs is hot swapped into the same bay, new interface instances are created for any new PIC types or PIC types that are in different bays (the old interface instances are discarded). For any PIC in the combination that is replaced by a PIC of the same type, interface instances are preserved.



The recessed Hot Swap button must be used when hot swapping PICs. See the PIC Quick Install Guide or PIC Hardware Reference for the correct procedure for hot swapping PICs.

How to Hot Swap an NSM



This procedure requires Software Release 2.3.1 or later.



WARNING: *Failure to follow this procedure when hot swapping an NSM will cause the switch or router to crash, and may damage the switch or router and files stored in Flash.*



The AT-AR040 NSM can be hot swapped with PICs installed in its PIC bays. There is no need to remove the PICs before hot swapping. See "Behaviour of Hot Swapped Interfaces" on page 17 for information on the operational characteristics of hot swapped interfaces.

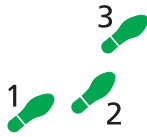

To hot swap an NSM:

1. Prepare the NSM bay for hot swap

If the In Use LED (next to the NSM bay) is lit, use a pencil tip or similar object to press the recessed Hot Swap button. The In Use LED should go out and the Swap LED should light.

If the In Use LED remains lit, or if neither the In Use or Swap LED are lit, the software release does not support hot swapping, and the Standard Installation Method must be used to install or remove the NSM.



Do not attempt to hot swap while the contents of Flash are being modified; for instance, during Flash compaction or when files are being loaded onto the switch or router. If the switch or router crashes while Flash is being modified, configuration files, software release files, feature licences and other files may be damaged.

2. Prepare the NSM

In an antistatic environment, remove the NSM from its packing material. Be sure to observe ESD precautions.



Do not attempt to install an NSM without observing correct antistatic procedures. Failure to do so may damage the switch, router, or NSM. If you are unsure what the 'correct' procedures are, contact your authorised Allied Telesyn distributor or reseller.

3. Remove the switch or router NSM-bay face-plate or existing NSM

If the switch or router does not have an NSM installed, remove the blank NSM-bay face-plate by loosening the two M4 Phillips screws.

If an NSM is already installed, disconnect its network cables and TNV lines before removing it from the switch or router.

Remove the NSM by unscrewing both thumbscrews at the same time. As the thumbscrews are turned, they will push the NSM out of the bay.

If the NSM has extractor levers, moving them to the open position will assist the removal process.



When removing an NSM, take care to turn each thumbscrew by an equal amount to ensure that the NSM does not become misaligned. Forcing a jammed thumbscrew may damage the NSM card.

If a thumbscrew becomes tight, it must not be forced. Instead, screw it in or out slightly to loosen it and then try again, taking care to unscrew both thumbscrews at the same rate.



Keep the face-plate for future use. If you remove an NSM, replace the face-plate to prevent dust and debris from entering the switch or router and to maintain proper airflow.

4. Slide the NSM into place

Slide the NSM into the NSM bay, making sure that the ends of the thumbscrews are aligned with the screw holes on the switch or router.

If the NSM has extractor levers, they should be in the closed position.

5. Secure the NSM

When the thumbscrews hit the threaded bushes, preventing the NSM from being pushed in further, turn the thumbscrews to engage their threads. Tighten both thumbscrews at the same rate to pull the NSM into position.

The screws will both tighten when the NSM panel is in its installed position, about .5mm proud of the switch or router rear panel. The thumbscrews should be firm, but not over-tight.

If one thumbscrew becomes tight before the other, loosen it slightly before proceeding.

6. Installing PICs in the AT-AR040 NSM

If you have PICs to install, install them now by following the *Port Interface Card Quick Install Guide*. If there are more PIC bays than PICs, use the bays on the switch or router base unit first, then fill the NSM PIC bays, starting with bay 0.

7. Return the NSM bay to use

Press the recessed Hot Swap button. The Swap LED will go out and the In Use LED will light.

If the In Use LED lights only briefly and the Swap LED then lights continuously, the NSM is of a type that the software release does not support.

8. Verify the installation

Check that the switch or router has recognised the NSM. Use the SHOW SYSTEM command. If there is no NSM entry in the output, the switch or router has failed to recognise the NSM.

If the In Use LED fails to light or Recognition fails, repeat the installation process, paying particular attention to steps 4 and 5.

If the reinstallation fails, use the Standard Installation Method or see the “Troubleshooting” on page 19.

Behaviour of Hot Swapped Interfaces

When an interface (PIC or NSM) is hot-swapped out, its interface instances become dormant. They stay dormant until either another interface of the same type is hot-swapped into the bay, in which case they are reactivated, or an interface of a different type is hot-swapped into the bay, in which case they are discarded.

Dormant interfaces are included in the SHOW INTERFACE command output and in the SNMP interfaces MIB, marked as swapped out. In other switch or router commands, however, the switch or router behaves as though dormant interfaces do not exist.

Instances of higher-level modules (such as LAPD and Q931, ISDNCC, PPP, and IP) do not become dormant when an interface becomes dormant. Instead they behave as if the interface has stopped communicating, for example, as if the cable has been unplugged.



The configuration script is not scanned for commands relating to hot-inserted interfaces until the switch or router is restarted. These interfaces must be configured manually.



The switch or router does not update the MAC address of any hot-swapped Ethernet interface until the switch or router is restarted.

The SHOW INTERFACE command is modified to show “Swapped out” in the ifOperStatus column for dormant interface instances (see Figure 12 on page 18 and Figure 13 on page 18).

All other commands that show or set interface properties behave as if swapped-out interfaces do not exist. Commands that operate on multiple interfaces skip swapped-out interfaces. Commands specified explicitly to a dormant interface display an error message.

Figure 12: Example output from the SHOW INTERFACE command.

```

Interfaces                                     sysUpTime:           00:00:46

DynamicLinkTraps.....Disabled
TrapLimit.....20

Number of unencrypted PPP/FR links.....0

ifIndex Interface      ifAdminStatus ifOperStatus          ifLastChange
-----
 1      eth0             Up            Up                    00:00:03
 2      eth1             Up            Down                  00:00:00
 3      bri0             Up            Swapped out          00:00:43
 4      eth2             Up            Swapped out          00:00:42
-----

Interface name summary

Interface Full name
-----
asyn0    asyn0
asyn1    asyn1
eth0     eth0
eth1     eth1
-----

```

Figure 13: Example output from the SHOW INTERFACE command for a specific interface.

```

Interface..... bri0
ifIndex..... 3
ifMTU..... 1712
ifSpeed..... 144000
ifAdminStatus..... Up
ifOperStatus..... Swapped out
ifLinkUpDownTrapEnable... Disabled
TrapLimit..... 20

Interface Counters

ifInOctets ..... 52190          ifOutOctets ..... 52190
ifInUcastPkts ..... 3070        ifOutUcastPkts ..... 3071
ifInNUcastPkts ..... 0          ifOutNUcastPkts ..... 0
ifInDiscards ..... 0           ifOutDiscards ..... 0
ifInErrors ..... 0             ifOutErrors ..... 0

```

Troubleshooting

This section provides information on how to detect and resolve problems with NSMs.

Other sources of troubleshooting information are:

- The Quick Install Guide and Hardware Reference for your switch or router.
- www.alliedtelesyn.co.nz/support/support.html

Performing the following tasks will eliminate the most common faults.

1. Check that the NSM is correctly installed. See the *Network Service Module Quick Install Guide* for a step by step guide to installing an NSM.
2. Make sure the power cord is securely connected to the switch or router and the power outlet.
3. Check that the power supply voltage to the switch or router is stable.
4. Check that the correct data cables are being used and that their connections are secure.
5. Make sure that other network devices are working properly.
6. Use the SHOW INSTALL command to check that the latest software release is loaded. The Software Reference for your switch or router has more information about obtaining and installing the latest software release.
7. If the switch or router is malfunctioning, reboot it by pressing the recessed Reset button or entering the command RESTART REBOOT. Alternatively, power OFF and ON the switch or router by disconnecting and reconnecting the main power supply (including, if connected, the RPS power).

LEDs and What They Mean

This section provides information on LEDs for NSMs and related hardware.

AT-AR040 NSM

The AT-AR040 NSM unit has no independent LEDs. See Table 5 on page 21 for information about related LEDs found on the base-unit switch or router.

AT-AR041 and AR042 NSMs

The AT-AR041 and AT-AR042 have two LEDs per port. The LEDs are located on the NSM's face-plate.

Table 3: AT-AR041 and AT-AR042 LEDs.

| LED | State | Function |
|--------|----------------|---|
| Active | Green | Lit when the BRI has successfully completed the exchange of INFO 1 and INFO 2 signals, and INFO 3 and INFO 4 signals are present on the link. This means the ISDN interface is correctly connected to a working NT device |
| | Off | There is no connection to the ISDN, or the ISDN has deactivated the connection |
| Data | Amber | For on-demand ISDN, lit when there is a call up over the respective B channel For permanent circuits, lit when HDLC packets are being exchanged between the switch or router and another TE end system device (normally another switch or router) over the respective B (data) channel |
| | Flashing Amber | For on-demand ISDN, flashing when data is being exchanged |
| | Off | For on-demand ISDN, Off when there is no active connection or when continuous data exchange is occurring For permanent ISDN circuits, Off when no data exchange is occurring |

AT-AR048

The AT-AR048 has the following LEDs on its face-plate.

Table 4: AT-AR048 LEDs.

| LED | State | Function |
|--------|-------|---|
| Active | Green | Lit when the Line Interface Unit (LIU) is receiving a signal |
| Loop | Green | Lit when any loopback is active |
| LOS | Amber | Lit when the received signal is lost. This usually indicates a network disruption, such as a cable being disconnected or a device failure |
| LOF | Amber | Lit when the DS3 framer cannot extract valid frames from the received signal |
| AIS | Amber | Lit when an Alarm Indication Signal is detected |
| FERF | Amber | Lit when a Far End Receive Failure signal is detected. This indicates the far end is receiving an AIS, LOS, or LOF signal |

Switch and router LEDs related to NSMs

Switches and routers with NSM bays have the following LEDs built into their chassis.

Table 5: Base-unit NSM LEDs (rear panel).

| LED | State | Function |
|--------------------|-------|---|
| In use(Rear panel) | Green | An NSM is installed, is receiving power, and is operational. The NSM and its PICs are not ready for hot swap |
| | Off | No NSM is installed, or the NSM is not installed correctly (the switch or router has not recognised the NSM) |
| Swap(Rear panel) | Green | The NSM and its PICs are ready to be hot swapped |
| | Off | The Hot Swap button must be pressed before the NSM or its PICs can be hot swapped, or the software release does not support hot swapping ¹ |

1. Hot swapping is supported by software release 2.3.1 or later.

PIC LEDs

The following tables may be helpful when diagnosing possible AT-AR040 NSM operational faults. These LEDs are located on the face-plate of the respective PIC. PICs are expansion options and must be purchased separately.

Table 6: PIC LEDs (AT-AR020 PRI E1/T1).

| LED | Function |
|--------|--|
| D Data | [ISDN mode only] Lit when HDLC packets are being exchanged between the switch or router and the ISDN switch over the D (signalling) channel |
| B Data | Lit when HDLC packets are being exchanged between the switch or router and another end system device (normally another switch or router) over any of the B (data) channels |
| Active | Lit whenever operational (i.e., no RAI or AIS set) frames are being received on the respective interface (PRI 0 or PRI 1) from another source |
| NT | [ISDN mode only] Lit when the PRI1 is operating in NT mode. This LED should not be lit during normal operation |

Table 7: PIC LEDs (AT-AR021(S) BRI-S/T).

| LED | Function |
|--------|---|
| B1, B2 | For on-demand ISDN, lit when there is a call up over the respective B channel and flashing when data is being exchanged For permanent circuits, lit when HDLC packets are being exchanged between the switch or router and another TE end system device (normally another switch or router) over the respective B (data) channel |
| Active | Lit when the BRI has successfully completed the exchange of INFO 1 and INFO 2 signals, and INFO 3 and INFO 4 signals are present on the link. This means that the ISDN interface is correctly connected to a working NT device |
| D | Lit when HDLC packets are being exchanged between the switch or router and the ISDN switch over the D (signalling) channel |

Table 8: PIC LEDs (AT-AR021(U) BRI-U).

| LED | Function |
|--------|---|
| B1, B2 | Lit when HDLC packets are being exchanged between the switch or router and another TE end system device (normally another switch or router) over the respective B (data) channel For ISDN, lit when there is a call up over the respective B channel and flashing when data is being exchanged |
| Active | Lit when the U interface is in the <i>Activated</i> state (i.e., it is in a fully operational at layer 1) |
| D | Lit when HDLC packets are being exchanged between the switch or router and the ISDN switch over the D (signalling) channel |

Table 9: PIC LEDs (AT-AR023 SYN).

| LED | Function |
|-----|---|
| Tx | Lit when data is being transmitted over the synchronous interface |
| Rx | Lit when data is being received on the synchronous interface |

Table 10: AT-AR026 4ETH PIC LED functions (Two LEDs per port).

| LED | Function |
|-------|---|
| Left | Lit when the port is operating at 100Mbps and full duplex. |
| Right | Lit when a link has been established. Flashing when data is being transmitted through the port. |

The AT-AR024 ASYN4 PIC does not have LEDs.

Contacting Us

With locations covering all of the established markets in North America, Latin America and Europe, Allied Telesyn provides localized sales and technical support worldwide. To find our representative nearest you, visit Allied Telesyn on the web at: <http://www.alliedtelesyn.com>.