

Rapier Series Switch Hardware Reference

Rapier G6
Rapier G6F-LX/SC
Rapier G6F-SX/SC
Rapier G6F-SX/MT-RJ
Rapier 8/8MT
Rapier 8/8SC
Rapier 16F-FX/MT
Rapier 16F-FX/SC
Rapier 16Fi-FX/MT
Rapier 16Fi-FX/SC
Rapier 24
Rapier 24i
Rapier 24i-B
Rapier 48
Rapier 48i
Rapier 48w
Rapier 48w-B

Download the complete document set from
www.alliedtelesis.com/support/software

Rapier Series Switch Hardware Reference
Document Number C613-03020-00 REV N

© 2008 Allied Telesis, Inc. All rights reserved. No part of this publication may be reproduced without prior written permission from Allied Telesis, Inc.

Allied Telesis, Inc. reserves the right to change specifications and other information in this document without prior written notice. The information provided herein is subject to change without notice. In no event shall Allied Telesis, Inc. be liable for any incidental, special, indirect, or consequential damages whatsoever, including but not limited to lost profits, arising out of or related to this manual or the information contained herein, even if Allied Telesis, Inc. has been advised of, known, or should have known, the possibility of such damages.

Allied Telesis and AlliedWare are trademarks or registered trademarks in the United States and elsewhere of Allied Telesis, Inc. Adobe, Acrobat, and Reader are either registered trademarks or trademarks of Adobe Systems Incorporated in the United States and/or other countries. Microsoft and Visio are either registered trademarks or trademarks of Microsoft Corporation in the United States and/or other countries. Apple and Macintosh are trademarks of Apple Inc., registered in the U.S. and other countries. Additional brands, names and products mentioned herein may be trademarks of their respective companies.

Contents

Models Covered by this Document	4
Hardware Overview	5
Rapier Switch Models	8
Rapier G6	8
Rapier G6F-LX/SC	8
Rapier G6F-SX/SC	8
Rapier G6F-SX/MT-RJ	9
Rapier 8/8MT	9
Rapier 8/8SC	9
Rapier 16F-FX/MT-RJ	10
Rapier 16Fi-FX/MT-RJ	10
Rapier 16F-FX/SC	10
Rapier 16Fi-FX/SC	11
Rapier 24	11
Rapier 24i and Rapier 24i-B	12
Rapier 48	12
Rapier 48i	12
Rapier 48w and Rapier 48w-B	13
LEDs and What They Mean	14
Switch Interfaces	17
Console Port	17
RJ-45 Ports	18
SFP Ports	20
Expansion Options	21
Uplink Modules	21
Network Service Modules	21
Port Interface Cards (PICs)	23
PCI Accelerator Cards (PACs)	24
Switch Cables and Loopback Plugs	28
Terminal and Modem Cables	28
Loopback Plugs for Testing Switch Interfaces	30
Port, Connector, and Cable Combinations	31
Redundant Power Supply	32
Fans and Filters on the Rapier 48w and 48w-B	33
AT-TFTP Server	37
Using Windows Terminal and Windows Hyperterminal	39
Switch Startup	42
To Log In	42
To Access Help	43
Startup Procedure	43
Test Facility	47
Diagnostics	49
Troubleshooting	51
Obtaining Documentation and Resources	53

Models Covered by this Document

This Hardware Reference contains information on the following devices:

- Rapier G6 switch
- Rapier G6F-LX/SC switch
- Rapier G6F-SX/SC switch
- Rapier G6F-SX/MT-RJ switch
- Rapier 8/8MT switch
- Rapier 8/8SC switch
- Rapier 16F-FX/MT-RJ switch
- Rapier 16Fi-FX/MT-RJ switch
- Rapier 16F-FX/SC switch
- Rapier 16Fi-FX/SC switch
- Rapier 24 switch
- Rapier 24i switch
- Rapier 24i-B switch
- Rapier 48 switch
- Rapier 48i switch
- Rapier 48w switch
- Rapier 48w-B switch
- AT-FAN04 fan-only module

You can download the complete document set for Rapier Series switches from www.alliedtelesis.com/support/software. For more information about the document set and other resources, see “[Obtaining Documentation and Resources](#)” on page 53.

Hardware Overview

This section provides an overview of the hardware features of Rapier Series switches. Rapier switches combine wire-speed Layer 2 and 3 switching with full multiprotocol routing capabilities to deliver low-latency high-bandwidth traffic capabilities to the desktop. Ethernet, fast Ethernet and gigabit Ethernet connectivity with both copper and fibre optic interfaces make the Rapier Series a versatile and powerful switching solution.

For information about uplink modules, see the *Uplink Module Hardware Reference*. For information about Network Service Modules (NSMs), see the *Network Service Module Hardware Reference*. For information about Port Interface Cards (PICs), see the *Port Interface Card Hardware Reference*. You can download these documents from www.alliedtelesis.com/support/software.

- Dimensions** All models except Rapier 48w and 48w-B
- Height: 66 mm, plus 5.5 mm if the rubber feet are used
 - Width: 440 mm, excluding rack-mounting brackets
 - Depth: 360 mm
 - Weight: Not more than 7 kg, depending on model and excluding NSMs, PICs, and power cord

Rapier 48w and 48w-B

- Height: 110 mm
- Width: 440 mm, excluding rack-mounting brackets
- Depth: 230 mm
- Weight: Not more than 8 kg, excluding NSMs, PICs, and power cord

- Mounting system** All models except Rapier 48w and 48w-B

- 1.5U rack mounting

Rapier 48w and 48w-B

- 2.5U rack mounting

- Environmental conditions** All models except Rapier 48w and 48w-B

- Operating temperature range: 0 to 40° C (32 to 104° F)
- Storage temperature range: -25 to 70° C (-13 to 158° F)
- Relative humidity range: 5 to 95% non-condensing

Rapier 48w and 48w-B

- Operating temperature range: 0 to 50° C (32 to 122° F)
- Storage temperature range: -25 to 70° C (-13 to 158° F)
- Operating relative humidity range: 5 to 95% non-condensing
- Operating altitude: maximum 3,050 metres (10,000 feet)

- Regulatory standards** All models except DC models of the Rapier 48w and 48w-B
- EMC: FCC CFR47 Part 15 Class A, EN55022 Class A, VCCI Class A, AS/NZS CISPR22 Class A, EN61000-3-2/3, EN55024
 - Safety: UL60950-1, CAN/CSA-C22.2 No. 60950-1-03, 21 CFR 1040, EN60950-1, AS/NZS 60950.1, EN 60825-1
- DC models of the Rapier 48w and 48w-B
- EMC: FCC CFR47 Part 15 Class A
 - Safety: UL60950-1, CAN/CSA-C22.2 No. 60950-1-03, 21 CFR 1040, EN60950-1, AS/NZS 60950.1, EN60825-1
 - NEBS: GR-1089-Core Issue 4, GR-63-Core Issue 3
- LEDs**
- Ethernet port and System status LEDs
 - “Find Me” LED display feature (Rapier 48w and 48w-B only)
 - For a complete list of LEDs and their functions, see [“LEDs and What They Mean” on page 14](#)
- NEBS** DC models of the Rapier 48w and 48w-B
- Meets the electrical criteria for NEBS certification
 - Meets the physical and air filtering criteria for NEBS certification
- Power supply** AC models except the Rapier 48w-B
- Universal 110–240VAC, 50–60Hz input
 - Redundant DC Power connection
- AC models of the Rapier 48w-B
- Universal 100-240 VAC, 50-60Hz, 2.0A input
- DC models except the Rapier 48w and 48w-B
- Input voltage 48VDC nominal, 39–60VDC is acceptable
 - 4Amps
 - Positive or negative earthing (grounding)
- DC models of the Rapier 48w and 48w-B
- Input voltage 48VDC nominal, 40–60VDC is acceptable
 - 4Amps
 - Positive or negative earthing (grounding).
 - 100W
 - Fuse rating of fuses F1 and F2 on the DC ORing/PEM board: 125VDC, 4A (e.g. Littelfuse 0451.004)
- Switching core** Rapier 16Fi-FX/MT, 16Fi-FX/SC, 24i, 24i-B, 48i, 48w, 48w-B
- Advanced ASIC switch chip
 - Non-blocking L2 and L3 IP switching

	Rapier 8/8MT, 8/8SC, 16F-FX/MT, 16F-FX/SC, 24, 48
	<ul style="list-style-type: none"> ■ ASIC switch chip ■ Non-blocking L2 and L3 IP switching
	Rapier G6, G6F/LX, G6F/SX, G6F/MT
	<ul style="list-style-type: none"> ■ Gigabit ASIC switch chip ■ Non-blocking L2 and L3 IP switching
Processing core	All models except Rapier 48w and 48w-B
	<ul style="list-style-type: none"> ■ 200MHz RISC processor (250MHz for Rapier 24<i>i</i> models with revision N or later PCBs) ■ 32MBytes Synchronous DRAM ■ 6MBytes flash memory (16MBytes for Rapier <i>i</i> models) ■ 128KBytes Non-volatile Storage (battery backed SRAM)
	Rapier 48w and 48w-B
	<ul style="list-style-type: none"> ■ 350MHz processor ■ 64MBytes Synchronous DRAM ■ 32MBytes flash memory ■ 512KBytes Non-volatile Storage (battery backed SRAM)
Asynchronous serial port	<ul style="list-style-type: none"> ■ Up to 115 kbps ■ Standard DB9 female RS-232 connector ■ Hardware-flow control ■ Two ports on Rapier 48w and 48w-B, one port on all other models
PCI Accelerator Card (PAC) slot	All models except Rapier 48, 48 <i>i</i> , 48w, 48w-B, G6, and G6F
	<ul style="list-style-type: none"> ■ Accepts an optional 32-bit PCI-based hardware encryption and/or compression card
Uplink module bays	All models except Rapier 48w and 48w-B
	<ul style="list-style-type: none"> ■ Two very high performance bays ■ Support for 1000BASE-T Ethernet uplink modules on all models ■ Support for 10BASE-T/100BASE-TX Ethernet uplink modules on Rapier G6 and Rapier <i>i</i> switches
Network Service Module (NSM) bay	All models except Rapier 48, 48 <i>i</i> , G6, G6F/SX, and G6F/LX
	<ul style="list-style-type: none"> ■ Support for one 32-bit PCI based WAN module
SFP ports	Rapier 48w and 48w-B
	<ul style="list-style-type: none"> ■ Two 1000BASE-X SFP ports

Rapier Switch Models

This section provides hardware descriptions for individual switch models.

Rapier G6

- 6 x 100BASE-TX/1000BASE-T ports (RJ-45 connectors)
- Two 10/100/1000BASE uplink bays
- Layer 3 managed switch

Figure 1: Front panel of the Rapier G6

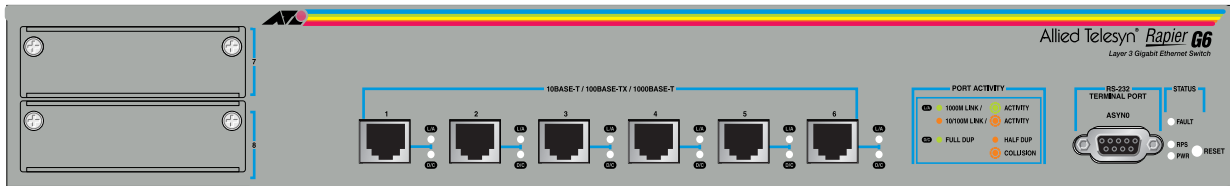

Rapier G6F-LX/SC

- 6 x 1000BASE-LX ports (SC fibre connectors)
- Two 10/100/1000BASE uplink bays
- Layer 3 managed switch

Figure 2: Front panel of the Rapier G6F/LX

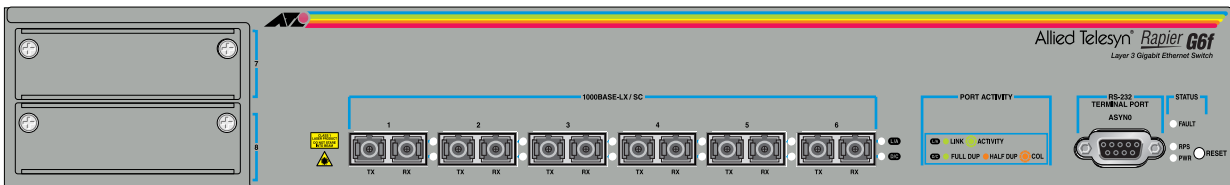

Rapier G6F-SX/SC

- 6 x 1000BASE-SX ports (SC fibre connectors)
- Two 10/100/1000BASE uplink bays
- Layer 3 managed switch

Figure 3: Front panel of the Rapier G6F/SX

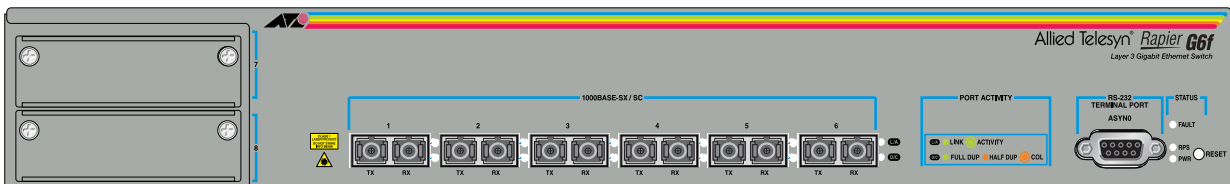

Rapier G6F-SX/MT-RJ

- 6 x 1000BASE-SX ports (MT-RJ fibre connectors)
- Two 10/100/1000BASE uplink bays
- Layer 3 managed switch

Figure 4: Front panel of the Rapier G6F/MT

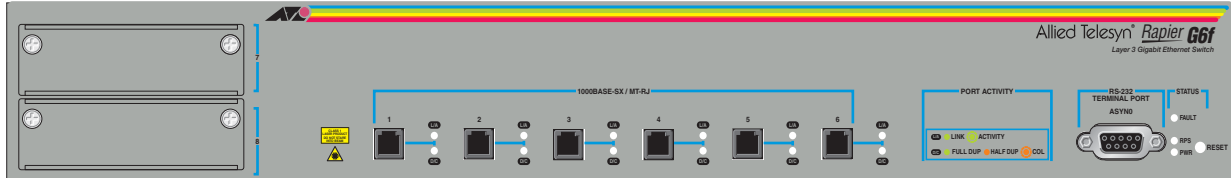

Rapier 8/8MT

- 8 x 10BASE-T/100BASE-TX ports (RJ-45 connectors)
- 8 x 100BASE-FX ports (MT-RJ fibre connectors)
- Two 1000BASE uplink bays
- One Network Service Module bay
- One PCI Accelerator Card (PAC) slot
- Layer 3 managed switch

Figure 5: Front panel of the Rapier 8/8MT

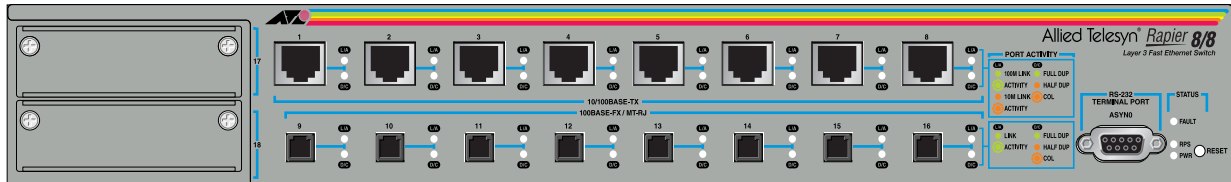

Rapier 8/8SC

- 8 x 10BASE-T/100BASE-TX ports (RJ-45 connectors)
- 8 x 100BASE-FX ports (SC fibre connectors)
- Two 1000BASE uplink bays
- One Network Service Module bay
- One PCI Accelerator Card (PAC) slot
- Layer 3 managed switch

Figure 6: Front panel of the Rapier 8/8SC

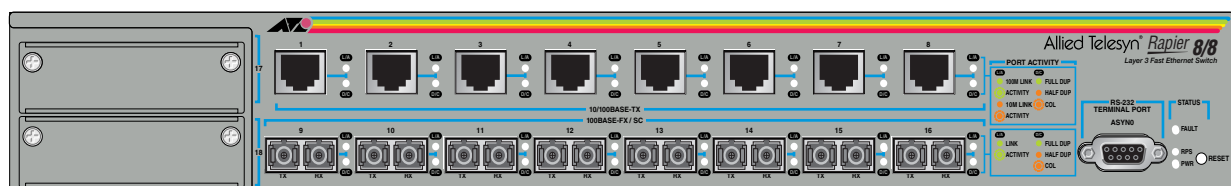

Rapier 16F-FX/MT-RJ

- 16 x 100BASE-FX ports (MT-RJ fibre connectors)
- Two 1000BASE uplink bays
- One Network Service Module bay
- One PCI Accelerator Card (PAC) slot
- Layer 3 managed switch

Figure 7: Front panel of the Rapier16F-FX/MT

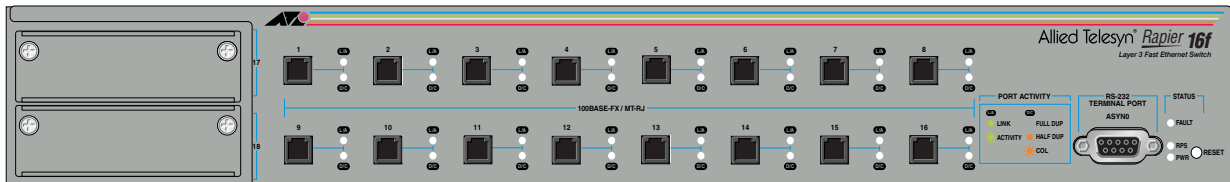

Rapier 16Fi-FX/MT-RJ

- 16 x 100BASE-FX ports (MT-RJ fibre connectors)
- Two 1000BASE uplink bays
- One Network Service Module bay
- One PCI Accelerator Card (PAC) slot
- Layer 3 managed switch
- Enhanced switching core

Figure 8: Front panel of the Rapier16Fi-FX/MT

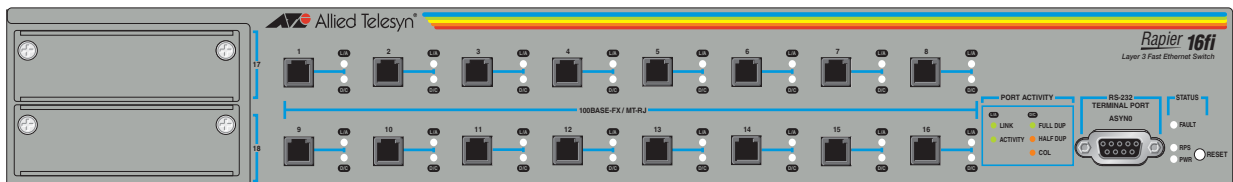

Rapier 16F-FX/SC

- 16 x 100BASE-FX ports (SC fibre connectors)
- Two 1000BASE uplink bays
- One Network Service Module bay
- One PCI Accelerator Card (PAC) slot
- Layer 3 managed switch

Figure 9: Front panel of the Rapier16F-FX/SC

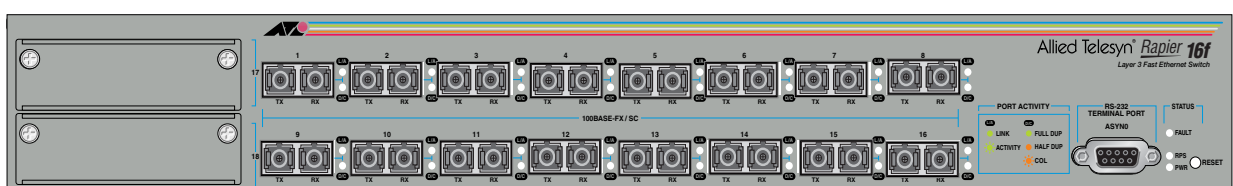

Rapier 16Fi-FX/SC

- 16 x 100BASE-FX ports (SC fibre connectors)
- Two 1000BASE uplink bays
- One Network Service Module bay
- One PCI Accelerator Card (PAC) slot
- Layer 3 managed switch
- Enhanced switching core

Figure 10: Front panel of the Rapier 16Fi-FX/SC

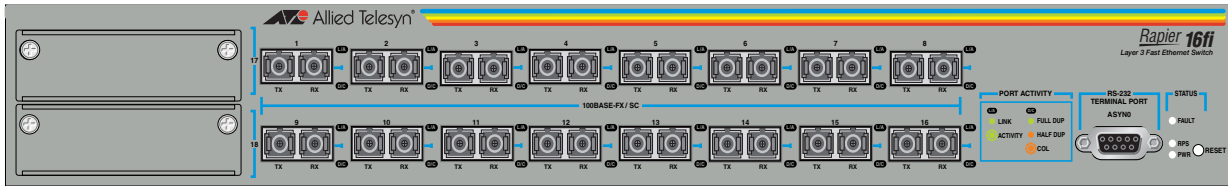

Rapier 24

- 24 x 10BASE-T/100BASE-TX ports (RJ-45 connectors)
- Two 1000BASE uplink bays
- One Network Service Module bay
- One PCI Accelerator Card (PAC) slot
- Auto-negotiating Layer 3 managed switch

Figure 11: Front panel of the Rapier 24

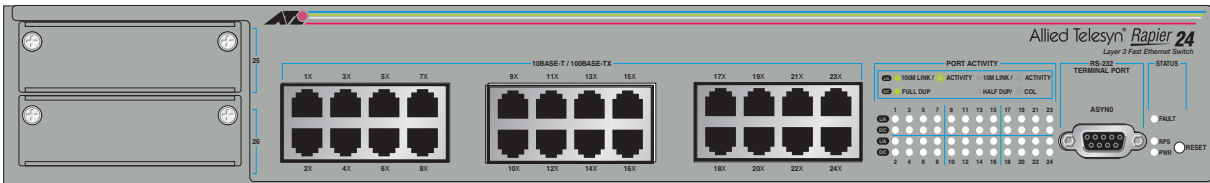
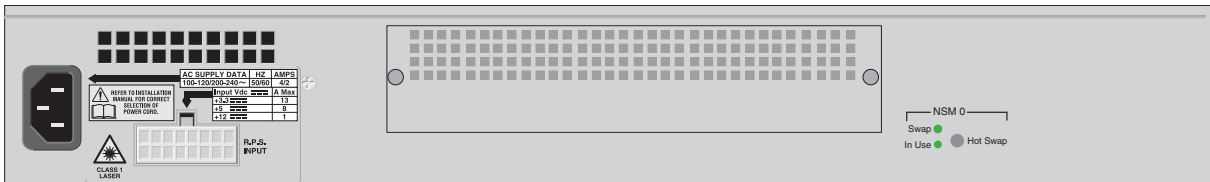

Figure 12: Rear panel of the Rapier 24 (AC model)



Rapier 24i and Rapier 24i-B

The Rapier 24i and 24i-B have the same features, but take different NSM model versions. See the section “[Network Service Modules](#)” on page 21 for the list of compatible NSMs.

- 24 x 10BASE-T/100BASE-TX ports (RJ-45 connectors)
- Two 10/100/1000BASE uplink bays
- One Network Service Module bay
- One PCI Accelerator Card (PAC) slot
- Auto-negotiating Layer 3 managed switch
- Enhanced switching core

Figure 13: Front panel of the Rapier 24i and 24i-B

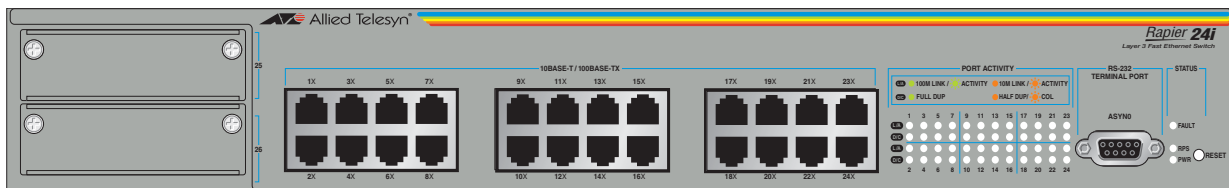

Rapier 48

- 48 x 10BASE-T/100BASE-TX ports (RJ-45 connectors)
- Two 1000BASE uplink bays
- Auto-negotiating Layer 3 managed switch

Figure 14: Front panel of the Rapier 48

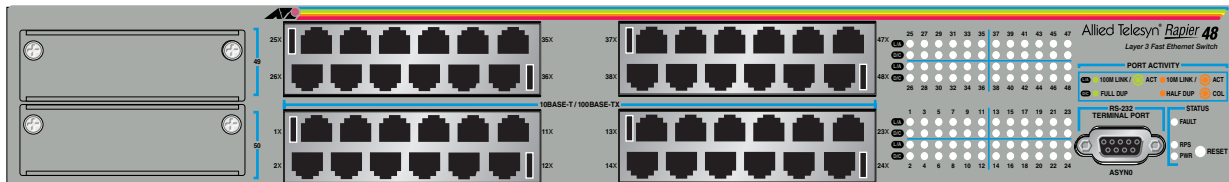

Rapier 48i

- 48 x 10BASE-T/100BASE-TX ports (RJ-45 connectors)
- Two 10/100/1000BASE uplink bays
- Auto-negotiating Layer 3 managed switch
- Enhanced switching core

Figure 15: Front panel of the Rapier 48i

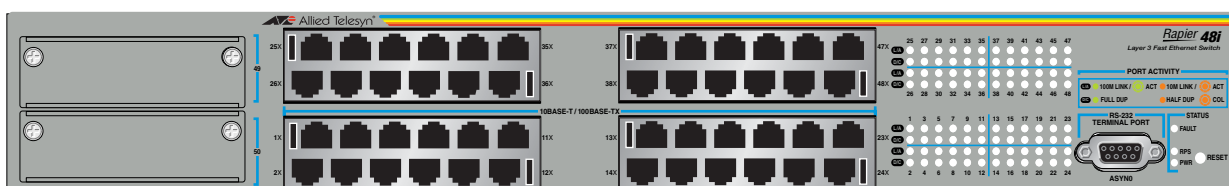

Rapier 48w and Rapier 48w-B

The Rapier 48w and 48w-B have the same features, but take different NSM model versions. See the section “Network Service Modules” on page 21 for the list of compatible NSMs.

The Rapier 48w is a DC model only, while the 48w-B is available in both AC and DC models. You can install the Rapier 48w and 48w-B DC models as Network Equipment Building System (NEBS) compliant. The AC model has not been tested for NEBS compliance.

- 48 x 10BASE-T/100BASE-TX ports (RJ-45 connectors)
- Two 1000BASE SFP ports
- Two asynchronous serial console ports with DB9 connectors
- One Network Service Module bay
- Auto-negotiating Layer 3 managed switch
- Enhanced switching core
- Replaceable air filters and fan-only modules (FOMs) for NEBS applications

Figure 16: Front panel of the Rapier 48w and 48w-B

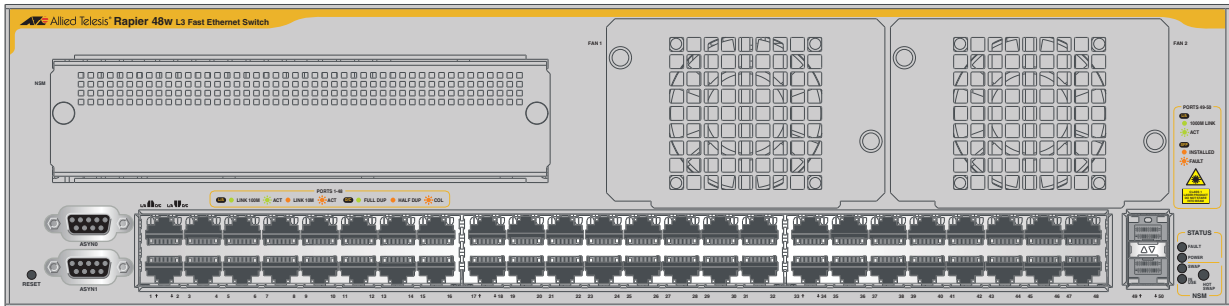
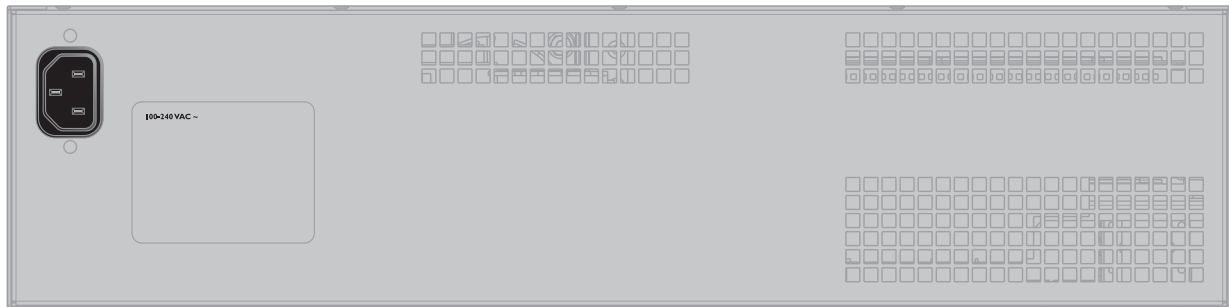

Figure 17: Rear panel of DC models



Figure 18: Rear panel of AC models



LEDs and What They Mean

The following LEDs report operations and faults on Rapier switches:

- System LEDs on the Rapier 48w and 48w-B
- System LEDs on all models except Rapier 48w and 48w-B
- Switch port LEDs on the Rapier G6
- Switch port LEDs on the Rapier G6F-LX/SC, G6F-SX/SC, and G6F-SX/MT-RJ
- Switch port LEDs on the Rapier 8/8SC, 8/8MT, 24, 24i 24i-B, 48, 48i, 48w, and 48w-B
- Switch port LEDs on the Rapier 16F-FX/SC, 16Fi-FX/SC, 16F-FX/MT-RJ, and 16Fi-FX/MT-RJ
- SFP Port LEDs on the Rapier 48w and 48w-B

Uplink modules, NSMs, and PICs are expansion options and must be purchased separately. For information about LEDs on uplink modules, NSMs, and PICs, see:

- *Uplink Module Installation and Safety Guide*
- *Uplink Module Hardware Reference*
- *Network Service Module Installation and Safety Guide*
- *Network Service Module Hardware Reference*
- *Port Interface Card Hardware Reference*

You can download these documents from www.alliedtelesis.com/support/software.

Table 1: System LEDs on the Rapier 48w and 48w-B

LED	State	Function
Power	Green	The switch is receiving power and the voltage is within the acceptable range.
Fault	Red	The switch or management software is malfunctioning.
	1 flash	A switch fan has failed.
In use (front panel)	Green	An NSM is installed, is receiving power, and is operational. The NSM and its PICs are not ready to be hot swapped.
	Off	No NSM is installed, or the switch has not recognised the NSM.
Swap (front panel)	Green	The NSM and its PICs are ready to be hot swapped.
	Off	The Hot Swap button must be pressed before the NSM or PICs can be hot swapped, or the software version does not support hot swapping ¹ .

1. Hot swapping is supported by Software Version 2.3.1 or later. AT-AR021(S) BRI S/T, AT-AR021(U) BRI U, and AT-AR023 SYN PICs can be hot swapped.

Table 2: System LEDs on all models except Rapier 48w and 48w-B

LED	State	Function
Power	Green	The switch is receiving power and the voltage is within the acceptable range.
Fault	Red	The switch or management software is malfunctioning
	1 flash	A switch fan has failed. The LED will not indicate an RPS fan failure).
	3 flashes	If an RPS is connected, the switch's PSU has failed.
	4 flashes	If RPS monitoring is enabled, the RPS PSU has failed.
	5 flashes	If RPS monitoring is enabled, an RPS is not connected or is not operational.
RPS ¹ (Redundant Power Supply)	Green	An RPS is connected to the switch.
In use ² (Rear panel)	Green	An NSM is installed, is receiving power, and is operational. The NSM and its PICs are not ready to be hot swapped.
	Off	No NSM is installed, or the switch has not recognised the NSM.
Swap ² (Rear panel)	Green	The NSM and its PICs are ready to be hot swapped.
	Off	The Hot Swap button must be pressed before the NSM or PICs can be hot swapped, or the software version does not support hot swapping ³ .

1. DC models do not have an RPS connector and the RPS LED will not function.

2. Not included on the Rapier 48, G6, G6F-SX/SC, G6F-X/SC, or G6F-SX/MT-RJ.

3. Hot swapping is supported by Software Version 2.3.1 or later. AT-AR021(S) BRI S/T, AT-AR021(U) BRI U, and AT-AR023 SYN PICs can be hot swapped.

Table 3: Switch port LEDs on the Rapier G6

LED	State	Function
L/A (Link/Activity)	Green	A 1000 Mbps link is open
	Amber	A 10 Mbps or 100 Mbps link is open
	Flashing Green	1000 Mbps activity is occurring
	Flashing Amber	10 Mbps or 100 Mbps activity is occurring
D/C (Duplex/Collision)	Green	The port is operating at full-duplex
	Amber	The port is operating at half-duplex
	Flashing Amber	Collisions are occurring on the line

Table 4: Switch port LEDs on the Rapier G6F-LX/SC, G6F-SX/SC, and G6F-SX/MT-RJ

LED	State	Function
L/A (Link/Activity)	Green	A 1000 Mbps link is open
	Flashing Green	1000 Mbps activity is occurring
D/C (Duplex/Collision)	Green	The port is operating at full-duplex
	Amber	The port is operating at half-duplex
	Flashing Amber	Collisions are occurring on the line

Table 5: Switch port LEDs on the Rapier 8/8SC, 8/8MT, 24, 24i 24i-B, 48, 48i, 48w, and 48w-B

LED	State	Function
L/A (Link/Activity)	Green	A 100 Mbps link is open
	Flashing Green	100 Mbps activity is occurring
	Amber	A 10 Mbps link is open
	Flashing Amber	10 Mbps activity is occurring
D/C (Duplex/Collision)	Green	The port is operating at full-duplex
	Amber	The port is operating at half-duplex
	Flashing Amber	Collisions are occurring on the line

Table 6: Switch port LEDs on the Rapier 16F-FX/SC, 16Fi-FX/SC, 16F-FX/MT-RJ, and 16Fi-FX/MT-RJ

LED	State	Function
L/A (Link/Activity)	Green	A 100 Mbps link is open
	Flashing Green	100 Mbps activity is occurring
D/C (Duplex/Collision)	Green	The port is operating at full-duplex
	Amber	The port is operating at half-duplex
	Flashing Amber	Collisions are occurring on the line

Table 7: SFP Port LEDs on the Rapier 48w and 48w-B

LED	State	Function
SFP	Green	A 1000Mbps link is open
	Flashing Green	1000Mbps link activity is occurring
	Amber	An SFP is installed but the switch has not recognised the SFP
	Flashing Amber	An SFP is installed but a Tx fault has occurred
	Off	No SFP installed

Switch Interfaces

This section provides pin assignments for the asynchronous console ports, RJ-45 switch ports, and the Redundant Power Supply (RPS) connector.

If you have installed a Port Interface Card (PIC), pin assignments for these can be found in the *Port Interface Card Hardware Reference*, which can be downloaded from www.alliedtelesis.com/support/software.

NEBS Compatibility

The DC models of the Rapier 48w and 48w-B have been tested to NEBS requirements.

The Ethernet and management/asyn intra-building ports of the Rapier 48w and 48w-B are suitable for connection to intra-building or unexposed wiring or cabling only. These ports must not be metalically connected to interfaces that connect to the OSP or its wiring. These interfaces are designed for use as intra-building interfaces only (Type 2 or Type 4 ports as described in GR-1089-CORE, Issue 4) and require isolation from the exposed OSP cabling. The addition of Primary Protectors is not sufficient protection in order to connect these interfaces metalically to OSP wiring.

The management/asyn intra-building ports can only be directly connected to equipment within the same frame, cabinet or line-up and where the equipment is separated by a distance of 6m or less. The exception to this is when intra-building wiring (cabling) is used for maintenance purposes only and is not connected during normal operation.

Console Port

All Rapier switches except the Rapier 48w and 48w-B have a single asynchronous serial RS-232 console port, labelled "RS-232 Terminal Port / asyn0". The Rapier 48w and 48w-B switches have two asynchronous serial RS-232 console ports, labelled "asyn0" and "asyn1".

The RS-232 console ports are used to connect the switch to a management device. For management purposes the switch's software can be accessed from a terminal, a PC running terminal emulation software, or from a remote location via a modem connection. You can also use the RS-232 console ports to establish a network connection from a remote site using SLIP and a modem.

The console ports have a DCE female connector (Figure 19). This allows the use of a straight-through cable when connecting the switch to a terminal or PC. Output from the **show asyn** command will, however, still have a DTE perspective. The internal DTE pin roles are listed in Table 8.

Figure 19: RS-232 Terminal Port Pin Numbers

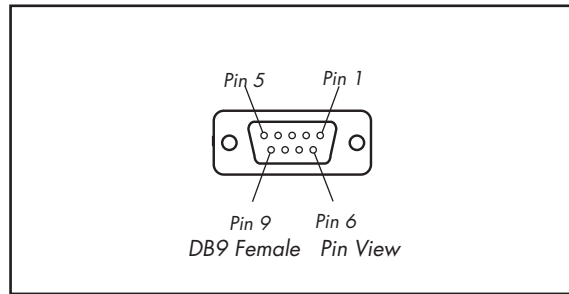

Table 8: Internal DTE pin roles

Pin	Role
2	TXD
3	RXD
4	CD
5	GND
6	DTR
7	CTS
8	RTS

See [“Terminal and Modem Cables”](#) on page 28 for more information on connection options for the RS-232 console ports.

RJ-45 Ports

For 10BASE-T/100BASE-TX connections, a twisted pair cable must be used. Each pair is identified by two different colours. For example, one wire might be red, and the other red with a white stripe. An RJ-45 connector must be fitted to both ends of the cable. [Figure 20](#) illustrates the pin layout for RJ-45 connectors.



Caution Do not plug a phone jack into an RJ-45 switch port because you could damage the switch. Use only twisted pair cables with RJ-45 connectors.

Figure 20: RJ-45 Pin layout

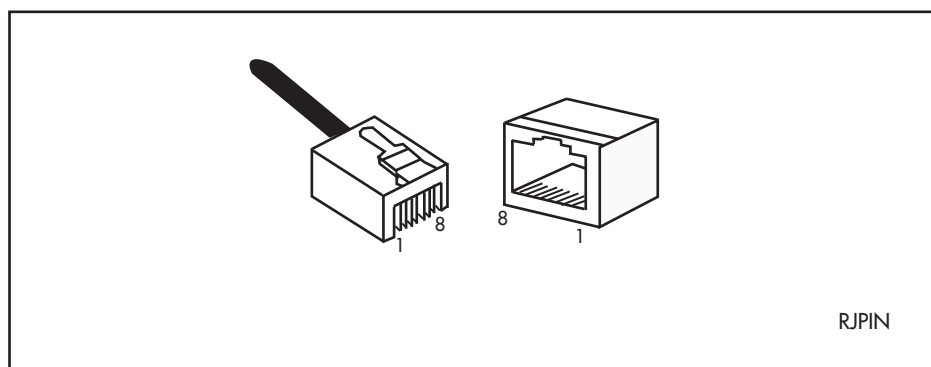

With 10BASE-T/100BASE-TX cables, pins 1 and 2 are used for transmitting data, while pins 3 and 6 are used for receiving data. [Table 9](#) on page 19 lists the RJ-45 Pin assignments.

Table 9: RJ-45 Pin assignments

Pin Number	Assignment ¹
1	TX+
2	TX-
3	RX+
6	RX-

1. The "+" and "-" signs represent the polarity of the wires that make up each wire pair.

If a twisted pair cable is to join two ports and only one of the ports has an internal crossover, the two pairs must be straight through, as listed in [Table 10](#).

Table 10: RJ-45 Pin assignments, straight through cable

End 1	End 2
1 (TX+)	1 (TX+)
2 (TX-)	2 (TX-)
3 (RX+)	3 (RX+)
6 (RX-)	6 (RX-)

If a twisted pair cable is used to join two ports and either both ports are labelled with an "X" or neither port is labelled with an "X", a crossover must be included in the wiring. [Table 11](#) lists the RJ-45 crossover wiring pin assignments.

Table 11: RJ-45 Pin assignments, crossover cable

End 1	End 2
1 (TX+)	3 (TX+)
2 (TX-)	6 (TX-)
3 (RX+)	1 (RX+)
6 (RX-)	2 (RX-)

For 1000BASE-T RJ-45 cables, all four pairs are used and the cable is wired in a straight-through configuration. [Table 12](#) lists the pin assignments.

Table 12: Pin assignments, 1000BASE-T RJ-45 cable

End 1	End 2
1 Pair 1+	1 Pair 1+
2 Pair 1-	2 Pair 1-
3 Pair 2+	3 Pair 2+
6 Pair 2-	6 Pair 2-
4 Pair 3+	4 Pair 3+
5 Pair 3-	5 Pair 3-
7 Pair 4+	7 Pair 4+
8 Pair 4-	8 Pair 4-

SFP Ports

SFP transceivers are compact, hot-swappable, and high speed. Different fibre and copper SFP transceivers are supported so that you can interchange port types to meet changing network requirements. SFP transceivers must be purchased separately.

Table 13 lists the SFP modules approved for use with the Rapier 48w and 48w-B switches. For the latest list of approved SFP transceivers, contact your authorised distributor or reseller.

Table 13: SFP transceivers supported by the Rapier 48w and 48w-B

Model	Media Type	Description
AT-SPTX	10/100/1000BASE-T	Copper, 100m at 1000Mbps, RJ-45 connector.
AT-SPSX	1000BASE-SX	850nm, 2m to 500m with 50/125µm MM fibre, 2m to 275m with 62.5/125µm MM fibre, LC connector.
AT-SPLX10	1000BASE-LX	1310nm, 2m to 10km with 9µm SM fibre, 2m to 550m with 50µm MM fibre, 2m to 550m with 62.5µm MM fibre, LC connector.
AT-SPLX40	1000BASE-LX	1310nm SM fibre up to 40km, LC connector.
AT-SPLX40/1550	1000BASE-LX	1550nm SM fibre up to 40km, LC connector.
AT-SPZX80	1000BASE-ZX	1550nm, 80km with 9µm SM fibre, LC connector.

Expansion Options

The following expansion options are available for Rapier switches:

- [Uplink Modules](#)
- [Network Service Modules](#)
- [Port Interface Cards \(PICs\)](#)
- [PCI Accelerator Cards \(PACs\)](#)

Uplink Modules

Uplink modules increase switching capacity by providing a maximum of two extra ports and by allowing switches to be linked together in stacks. For the Rapier series, uplink modules with gigabit capacity are available.

The following uplink modules are supported on Rapier switches:

- AT-A35-SX/SC, 1 x 1000BASE-SX port (SC connector)
- AT-A35-LX/SC, 1 x 1000BASE-LX port (SC connector)
- AT-A39-T/RJ-45, 1 x 1000BASE-T port (RJ-45 copper connector)
- AT-A40/SC, 1 x 100BASE-FX Multimode Fibre port (SC connector)
- AT-A40/MT, 1 x 100BASE-FX Multimode Fibre port (MT-RJ connector)
- AT-A41/SC, 1 x 100BASE-FX Singlemode Fibre port (SC connector)
- AT-A41/MT, 1 x 100BASE-FX Singlemode Fibre port (MT-RJ connector)
- AT-A42/GBIC, 1 x 1000BASE-X GBIC port

For more information about installing uplink modules, see the *Uplink Module Installation and Safety Guide*, which is included with every uplink module or can be downloaded from www.alliedtelesis.com/support/software.

For more information about the hardware features of uplink modules, and which modules are supported by different models of Rapier switch, see the *Uplink Module Hardware Reference*, which can be downloaded from www.alliedtelesis.com/support/software.

Network Service Modules

Network Service Modules (NSMs) provide additional WAN interface types, either directly or via Port Interface Card (PIC) expansion bays.

The following NSMs are available:

- AT-AR040 and AT-AR040-B, four Port Interface Card (PIC) expansion bays
- AT-AR041, eight ISDN Basic Rate S/T interfaces
- AT-AR042, four ISDN Basic Rate S/T interfaces
- AT-AR048 and AT-AR048-B, one unchannelised DS3 interface

[Table 14 on page 22](#) shows which NSMs are appropriate for different models of Rapier switch.

Table 14: Compatible Rapier switches for Network Service Modules (NSMs)

Model(s)	AR040	AR040-B	AR041	AR042	AR048	AR048-B
Rapier 8/8 (MT & SC) switch	✓		✓	✓		
Rapier 16F-FX (MT-RJ & SC) switch	✓		✓	✓		
Rapier 16Fi-FX (MT-RJ & SC) switch	✓		✓	✓		
Rapier 24 switch	✓		✓	✓		
Rapier 24i switch	✓		✓	✓	✓	
Rapier 24i-B switch		✓				✓
Rapier 48w switch	✓				✓	
Rapier 48w-B switch		✓				✓

Maximum DS3 packet forwarding rates are achieved only when the AT-AR048 is installed in a Rapier 48w switch, or a Rapier 24i switch whose serial number ends with the letter N or higher. If maximum DS3 performance is not required, you can install the AT-AR048 in any Rapier 24i whose serial number ends in J or later. You can find the serial number on the underside of the switch (Figure 21).

The AT-AR048-B NSM can only be installed in Rapier 48w-B and Rapier 24i-B switches. This NSM will achieve Maximum DS3 packet forwarding rates in both of these switches.

Figure 21: Serial number label on the underside of a Rapier 24i

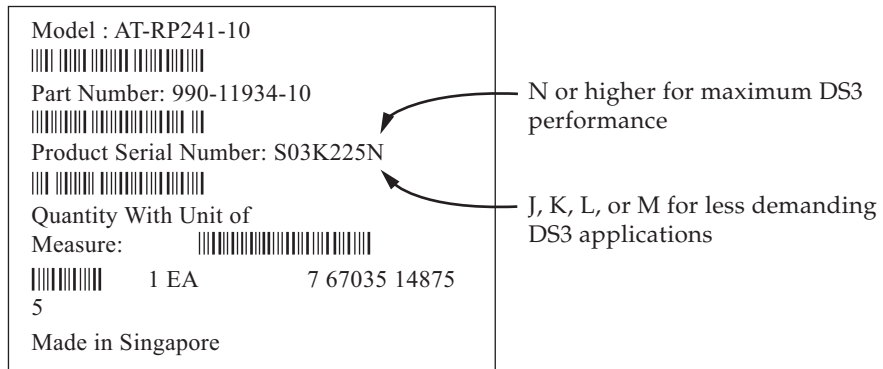

For more information about installing NSMs, see the *Network Service Module Installation and Safety Guide*, which is included with every NSM or can be downloaded from www.alliedtelesis.com/support/software.

For more information about the hardware features of NSMs, guidelines and limits, see the *Network Service Module Hardware Reference*, which can be downloaded from www.alliedtelesis.com/support/software.

For more information about which PICs are supported by different combinations of Rapier switches and the AT-AR040 and AT-AR040-B NSMs, see the *Port Interface Card Installation and Safety Guide*, which is included with every PIC, or the *Port Interface Card Hardware Reference*. You can download these documents from www.alliedtelesis.com/support/software.

Port Interface Cards (PICs)

PICs provide a cost effective and flexible mechanism for adding new or additional WAN network interfaces to Rapier switches. By adding or changing PICs, the switch's network interface capabilities can be upgraded without replacing the switch itself. A PIC can provide additional network interfaces, or can be replaced with a different PIC to provide alternative interface types.

The following PICs are supported on Rapier switches:

- AT-AR020 PRI E1/T1
- AT-AR021 (S) BRI S/T
- AT-AR021 (U) BRI U
- AT-AR023 SYN
- AT-AR024 ASYN4
- AT-AR027 VoIP-FXS

The AT-AR022 ETH PIC and AT-AR026 4ETH PIC are not supported on the Rapier switch because performance of these interfaces is likely to be reduced and packet loss may occur.

The AT-AR040 and AT-AR040-B NSM must be installed before PICs can be used with a Rapier switch. [Table 15](#) shows which PICs are appropriate for compatible models of Rapier switch for the AT-AR040 NSM. [Table 16](#) shows which PICs are appropriate for compatible models of Rapier switch for the AT-AR040-B NSM.

Table 15: Compatible Rapier switches for Port Interface Cards (PICs) in an AT-AR040 NSM

Model	AR020	AR021v2	AR021v3	AR021 (U)	AR023	AR024	AR027
		(S/T)	(S/T)				
Rapier 8/8 (MT, SC)	✓	✓		✓	✓	✓	✓
Rapier 16F-FX (MT-RJ, SC)	✓	✓		✓	✓	✓	✓
Rapier 16Fi-FX (MT-RJ, SC)	✓	✓	✓	✓	✓	✓	✓
Rapier 24	✓	✓		✓	✓	✓	✓
Rapier 24i	✓	✓	✓	✓	✓	✓	✓
Rapier 48w	✓		✓			✓	

Table 16: Compatible Rapier switches for Port Interface Cards (PICs) in an AT-AR040-B NSM

Model	AR020	AR021v2	AR021v3	AR021 (U)	AR023	AR024	AR027
		(S/T)	(S/T)				
Rapier 24i-B	✓	✓	✓	✓	✓	✓	✓
Rapier 48w-B	✓		✓			✓	

The AT-AR021(S) V3 hardware revision, identified by the label "AR021v3" on the board, requires a switch running AlliedWare® Operating System version 2.9.1-13 or later.

For more information about installing PICs, see the *Port Interface Card Installation and Safety Guide*, which is included with every PIC or can be downloaded from www.alliedtelesis.com/support/software.

For more information about the hardware features of PICs, WAN cables, and testing PICs, see the *Port Interface Card Hardware Reference*, which can be downloaded from www.alliedtelesis.com/support/software.

PCI Accelerator Cards (PACs)

PCI Accelerator Cards (PACs) provide hardware data compression and encryption on Rapier switches. A PAC is a hardware processing unit controlled by the switch's CPU. A PAC can be installed in the dedicated PAC slot on all Rapier switches except the Rapier 48, Rapier 48i, Rapier 48w, Rapier 48w-B, Rapier G6, and Rapier G6F.



Warning Only authorised service personnel should install a PAC. Opening the switch's lid may cause personal injury from electric shock, could damage the switch, and will invalidate the product warranty.

Two PACs are available:

- AT-AR060 EPAC, Encryption PAC
- AT-AR061 ECPAC, Encryption/Compression PAC

How PACs work

PACs have their own processor which operates independently of the base system. This processor is responsible for the transfer of data between the base system and the PAC, and the control of local high speed encryption and compression data processing devices.

This architecture allows data encoding to be performed off-line without involving the base switch processor, maximising PAC performance while minimising the impact on the switch.

Compression

PAC-based compression has the following features:

- Local 32-bit processor for high speed control and data transfer.
- Dedicated high performance 32-bit compression hardware.
- High compression ratio Lempel-Ziv algorithm in hardware.
- 2 MBytes of history memory.
- Support for up to 127 compression channels.

Compression and decompression operations are performed by a 32-bit data compression coprocessor specifically designed for high-performance Lempel-Ziv compression applications. 2MBytes of history memory allows up to 127 separate data links to use compression concurrently, enabling PACs to provide compression for complicated network architectures. [Figure 22 on page 25](#) shows typical compression ratios achieved by a PAC for a representative set of file types.

Encryption

PAC-based encryption has the following features:

- Local 32-bit processor for high speed control and data transfer.
- Dedicated high performance 32-bit Data Encryption Standard – DES and Triple DES (3DES) – hardware.

PAC DES and triple DES encryption are based on a fast 32-bit device that complies with FIPS PUB 46, ISO DEA-1 and ANSI X3.92 standards.

Figure 22: Typical hardware compression ratios by file type

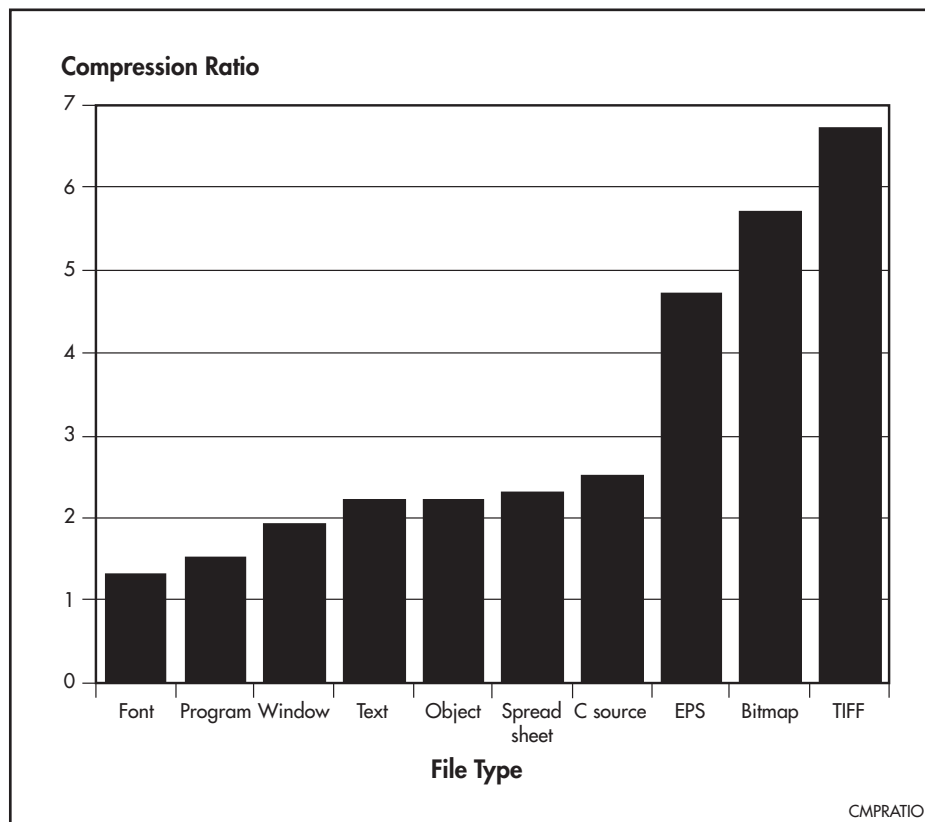

Dual mode Throughput of an encrypted link can be dramatically increased by using data compression. To support this, ECPACs provide a dual mode that allows combined compression and encryption operations. Data compression occurs before encryption, to that the compression phase has the best opportunity to find non-random data.

Adding compression to an encrypted link increases line throughput. Compression reduces the amount of data to be encrypted and transferred over the network, so less system and network link bandwidth is required for a given amount of data. This makes the dual operation very effective where encryption is required.

Verifying installation To confirm that the PAC is installed and operating correctly, check that the switch has recognised the it. Turn on the switch and enter the following command to display system information:

```
show system
```

For more information about this command, see the *Configuring and Monitoring the System* chapter of the *Rapier Series Switch AlliedWare® Operating System Software Reference*.

The first part of the display shows details of the base unit and expansion options installed in the switch (Figure 23 on page 26). There should be at least two entries, one for the switch base unit and one for the PAC. Both the serial number and the part name should be displayed.

Record the serial number and revision of the base unit and PAC for later reference. If you have any difficulty with the PAC at any time, contact your authorised Allied Telesis distributor or reseller and quote the serial numbers and revision of both the base unit and the PAC.

If there is no entry for the PAC then the switch's boot process has not correctly detected the card's presence. The most likely cause is that there is no PAC installed, or the PAC is not correctly installed in the switch. Contact your authorised Allied Telesis distributor or reseller.

Figure 23: Example output from the **show system** command for a Rapier switch with an AT-AR061 ECPAC installed

```

Switch System Status                               Time 00:23:04 Date
15-Jun-2001.
Board      ID  Bay Board Name                               Rev   Serial number
-----
Base       86   AT-RP24  Rapier 24                               M2-1  46690596
PAC        153  AR061 ECPAC                               P1-16 6844578
-----
Memory -   DRAM : 32768 kB   FLASH : 6144 kB
-----
SysDescription
Allied Telesyn AT-RP24 version 2.2.2-00 18-May-2001
.
.
.

```

Next, check the status of the PAC by displaying a log of PAC events, using the command:

```
show log
```

For more information about this command, see the *Logging Facility* chapter of the *Rapier Series Switch AlliedWare® Operating System Software Reference*. A typical display is shown in [Figure 24](#).

Figure 24: Example output from the SHOW LOG command for a Rapier switch with an AT-AR061 ECPAC card installed

```

Date/Time   S Mod  Type  SType Message
-----
15 00:05:50 4 ENCO ENCO  PAC   7751 Found. Initialisation started
15 00:05:50 4 ENCO ENCO  PAC   7751 Initialisation Successful
15 00:05:50 7 SYS  REST  NORM  Switch startup, ver 2.2.2-00, 18-May-2001, Clock
Log: 00:04:40 on 15-Jun-2001
15 00:05:53 3 USER USER  00011 manager login failed on port0
15 00:05:58 3 USER USER  LON   manager login on port0
15 00:05:59 3 CH  MSG   WARN  No patches found
-----

```

If the log shows that the PAC was not recognised or could not be initialised, contact your authorised Allied Telesis distributor or reseller.

Testing functionality

When the PAC is operating, you can test its functionality by using the Test Facility software or by configuring a module to use it. For more information about the Test Facility, see the *Test Facility* chapter of the *Rapier Series Switch AlliedWare® Operating System Software Reference*. For more information about configuring interfaces, see the *Compression and Encryption Services* chapter of the *Rapier Series Switch AlliedWare® Operating System Software Reference*.

The Test Facility is built into the AlliedWare operating system, and is the easiest way to verify a PAC's operation. To run the test facility for a PAC, use the command:

```
enable test interface=pac
```

The test runs 4 minutes. To view the results of the test at any time, use the command:

```
show test
```

Figure 25 shows a typical output. The status of the test will be shown in the right-hand column.

If you are unsure about running the Test Facility, or want help evaluating the results, contact your authorised Allied Telesis distributor or reseller.

Figure 25: Example output from the **show test** command for a Rapier switch with an AT-AR061 ECPAC installed

Board	ID	Bay	Board Name	Rev	Serial number
Base	86		AT-RP24 Rapier 24	M2-1	46690596
PAC	153		AR061 ECPAC	P1-16	6844578

Interface	State	Result	Type	Duration (minutes)	Details Data(%OK)
Control					
port1	no test	-	-	-	-
port2	no test	-	-	-	-
port3	no test	-	-	-	-
port4	no test	-	-	-	-
port5	no test	-	-	-	-
port6	no test	-	-	-	-
port7	no test	-	-	-	-
port8	no test	-	-	-	-
port9	no test	-	-	-	-
port10	no test	-	-	-	-
port11	no test	-	-	-	-
port12	no test	-	-	-	-
port13	no test	-	-	-	-
port14	no test	-	-	-	-
port15	no test	-	-	-	-
port16	no test	-	-	-	-
port17	no test	-	-	-	-
port18	no test	-	-	-	-
port19	no test	-	-	-	-
port20	no test	-	-	-	-
port21	no test	-	-	-	-
port22	no test	-	-	-	-
port23	no test	-	-	-	-
port24	no test	-	-	-	-
enco0	testing	wait 4 minutes	DES	< 1	good(100.0) -
enco1	testing	wait 4 minutes	STAC	< 1	good(100.0) -

Switch Cables and Loopback Plugs

This section describes how to make cables for connecting the switch's interfaces to networks, terminals, and printers. How to make loopback plugs for testing switch interfaces is also described.

Descriptions of cables and loopback plugs for NSMs and PICs can be found in the *Network Service Module Hardware Reference* and the *Port Interface Card Hardware Reference*. These documents can be downloaded from www.alliedtelesis.com/support/software.

Terminal and Modem Cables

Figure 26 shows how to wire cables to connect a standard VT100 compatible terminal, or a modem, to the switch's RS-232 Terminal Port.

For NEBS compatibility, the cable must be shielded and grounded at both ends, especially if permanently connected.

Figure 26: Pin wiring diagram for a standard DB9 male to female terminal cable

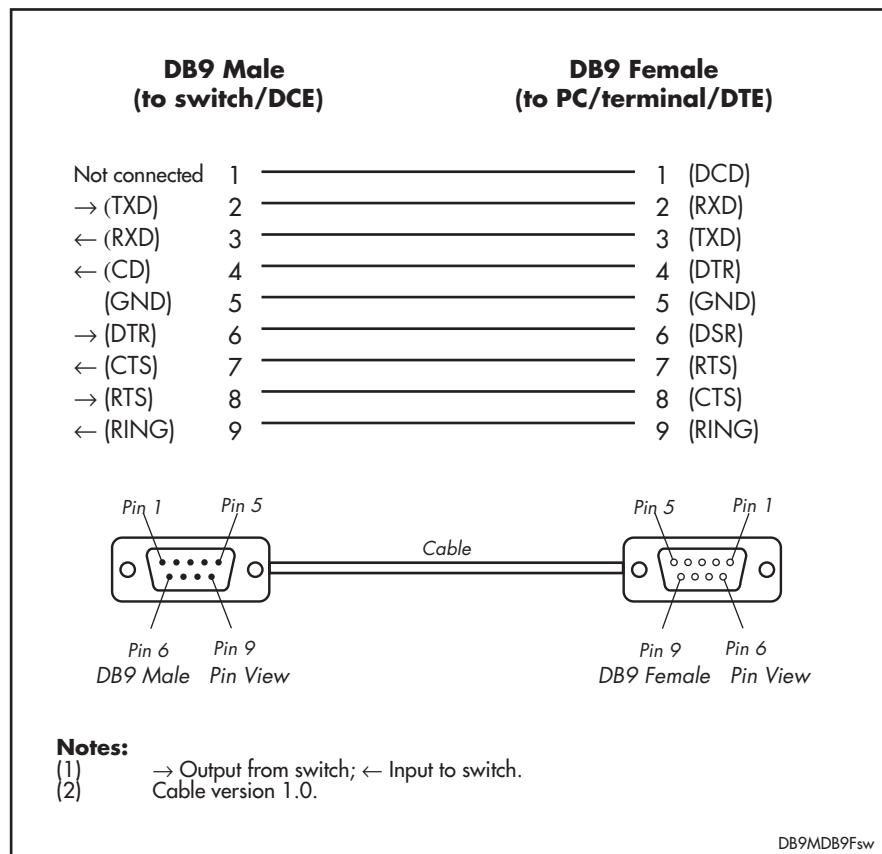
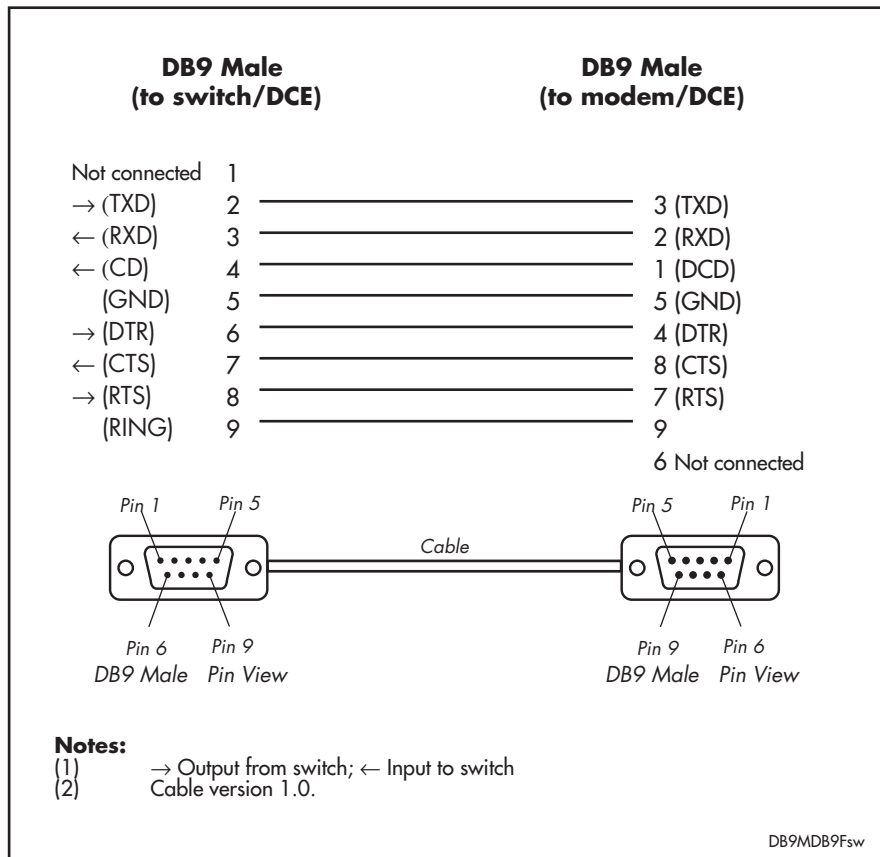

Figure 27: Pin wiring diagram for a DCE RS-232 Terminal Port (DB9 female connector) male to male modem cable



The switch’s RS-232 Terminal Port has a DCE female socket. This allows the use of a straight-through cable when connecting the switch to a terminal or PC. Output from the SHOW ASYN command will, however, still have a DTE perspective. The internal DTE pin roles are listed in [Table 17](#).

Table 17: Internal DTE pin roles

Pin	Role
2	TXD
3	RXD
4	CD
5	GND
6	DTR
7	CTS
8	RTS

Loopback Plugs for Testing Switch Interfaces

Loopback plugs are used in conjunction with the Test Facility in the AlliedWare operating system to test the physical interfaces on the switch, Network Service Modules (NSMs) and Port Interface Cards (PICs). For more information about the Test Facility, see “[Test Facility](#)” on page 47, and the *Test Facility* chapter of the *Rapier Series Switch AlliedWare® Operating System Software Reference*.

A loopback plug connects the output pins on the interface to the input pins so that any data transmitted over the interface is looped back (hence *loopback* plug) and received at the same interface.

On interfaces with control signals, these are also looped back. The data received on the interface is compared with the data transmitted to determine whether or not the interface is functioning correctly. In order to produce a comprehensive test report for the interface being tested, most tests performed by the Test Facility require a loopback plug to be inserted.

[Figure 28](#) shows how to wire a loopback to test Ethernet 10/100 switch ports. Gigabit copper interfaces cannot be looped back. Use a four-pair crossover cable between two ports and enter the **enable test interface=all** command.

Figure 28: Ethernet twisted pair (TP) loopback plug

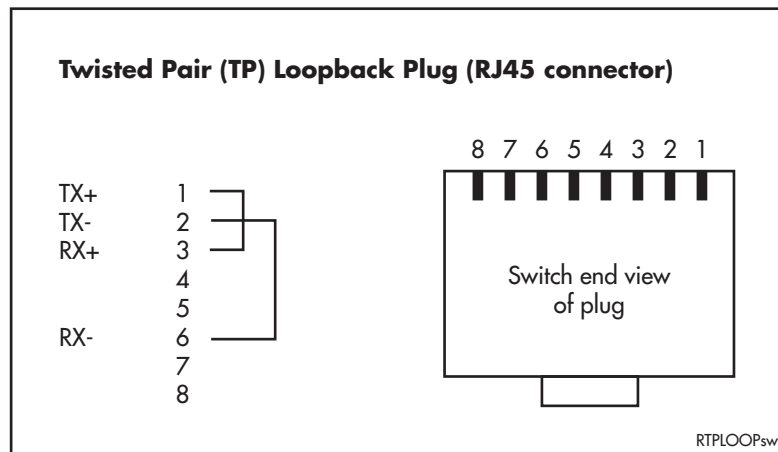

For information about testing WAN interfaces on NSMs and PICs, see the *Network Service Module Hardware Reference* and the *Port Interface Card Hardware Reference*. These documents can be downloaded from www.alliedtelesis.com/support/software.

Port, Connector, and Cable Combinations

This section provides cabling guidelines for each switch model.

Table 18: Cable guidelines

Model	Port Type(s)	Connector Type(s)	Cable Type ¹	Maximum Cable Length
Rapier 8/8SC Rapier 8/8MT Rapier 24 Rapier 24i Rapier 24i-B Rapier 48 Rapier 48i Rapier 48w Rapier 48w-B	10BASE-T/ 100BASE-TX	RJ-45	10BASE-T Category 3 or better 100BASE-TX Category 5 or better	100m (328ft) 100m (328ft)
Rapier 16F-FX/SC Rapier 16Fi-FX/SC Rapier 8/8SC	100BASE-FX	SC	50/125 or 62.5/125 micron multimode fibre	Full-duplex 2km (6,600ft) Half-duplex 412m (1360ft)
Rapier 16F-FX/MT-RJ Rapier 16Fi-FX/MT-RJ Rapier 8/8MT	100BASE-FX	MT-RJ	50/125 or 62.5/125 micron multimode fibre	Full-duplex 2km (6,600ft) Half-duplex 412m (1360ft)
Rapier G6	1000BASE-T	RJ-45	CAT5	100 (328ft)
Rapier G6F-LX/SC	1000BASE-LX	SC	9/125 micron singlemode fibre 50/125 or 62.5/125 micron multimode fibre	3km (1.8mi) Increasing to 10km (6mi) if linking two 1000BASE-LX models 550m (1804ft) ²
Rapier G6F-SX/SC	1000BASE-SX	SC	50/125 micron multimode fibre 62.5/125 micron multimode fibre	550m (1,804ft) ² 275m (902ft) ³
Rapier G6F-SX/MT-RJ	1000BASE-SX	MT-RJ	50/125 micron multimode fibre 62.5/125 micron multimode fibre	550m (1,804ft) ² 275m (902ft) ³
Rapier 48w Rapier 48w-B	1000BASEX	Varies with SFP	Refer to documentation with SFP	Refer to documentation with SFP

1. Refer to the IEEE 802.3 standards for further cable information

2. Assumes a fibre optic cable rating of 500 Mhz/Km. (Maximum cable length is 500m at a cable rating of 400 Mhz/Km.)

3. Assumes a fibre optic cable rating of 200 Mhz/Km. (Maximum cable length is 220m at a cable rating of 160 Mhz/Km.)

Redundant Power Supply

All AC models of Rapier switches, except the Rapier 48w-B, have a Redundant Power Supply (RPS) connector on their rear panel. [Table 19](#) lists the connector's pin numbers and pin functions.

Table 19: RPS Connector Pin Numbers and Functions

Pin Number	Function
1	+12 VDC
2	Remote Sense (RS) +5 VDC
3	Remote Sense (RS) Ground
4	Remote Sense (RS) +3.3 VDC
5	Redundant Power Supply (RPS) Present
6	Ground (+3.3 VDC Return)
7	Ground (+5 VDC Return)
8	+5 VDC
9	Ground (+12 VDC Return)
10	+3.3 VDC
11	Ground (+3.3 VDC Return)
12	+3.3 VDC
13	Ground (+3.3 VDC Return)
14	+3.3 VDC
15	+5 VDC
16	Ground (+5 VDC Return)

[Table 20](#) illustrates the connector's pin layout.

Table 20: RPS Connector's Pin Layout

16	15	14	13	12	11	10	9
8	7	6	5	4	3	2	1

Pin 16 is at the connector's top left, while pin 1 is at its lower right.

Fans and Filters on the Rapier 48w and 48w-B

The Rapier 48w and 48w-B have two fan-only modules (FOMs) located on the front. For NEBS compliance, Rapier 48w and 48w-B DC models are supplied with two air filters that you must install into each FOM, and should be changed periodically. The efficiency period of the air filter will depend on the air quality in which the switch is operated, but for a normal office environment, we recommend replacing the air filters every 3 months.

The following procedures describe how to replace FOMs and air filters. Replacement FOMs (part number AT-FAN-04) and air filters must be purchased separately from your authorised Allied Telesis distributor or reseller.

You do not need to power down the switch to change a FOM or air filter, but you should replace them one at a time.

Before you begin

- Read the safety information for the switch.

Safety information is available in the *Rapier 48w Switch Installation and Safety Guide* bundled with every Rapier 48w and 48w-B switch. You can also download this document from www.alliedtelesis.com/support/software.

- Gather necessary tools and equipment.

You will need a flat screwdriver to adjust the captive screws on the FOM.

We recommend installing new air filters when you replace a FOM.

To replace a FOM

1. Unpack the fan-only module.



Warning Follow correct anti-static procedures when installing a FOM. Failure to do so could damage the FOM or the switch. If you are unsure about correct procedures, contact your authorised distributor or reseller.

While observing Electrostatic Discharge (ESD) precautions, remove the FOM from its packing material in an anti-static environment.

2. Remove the current fan-only module from the switch.

Using a flat screwdriver, loosen the captive screws on the faceplate of the FOM, and slide the FOM out of its cage. The internal power connection is quite solid so pull firmly on the captive screws.

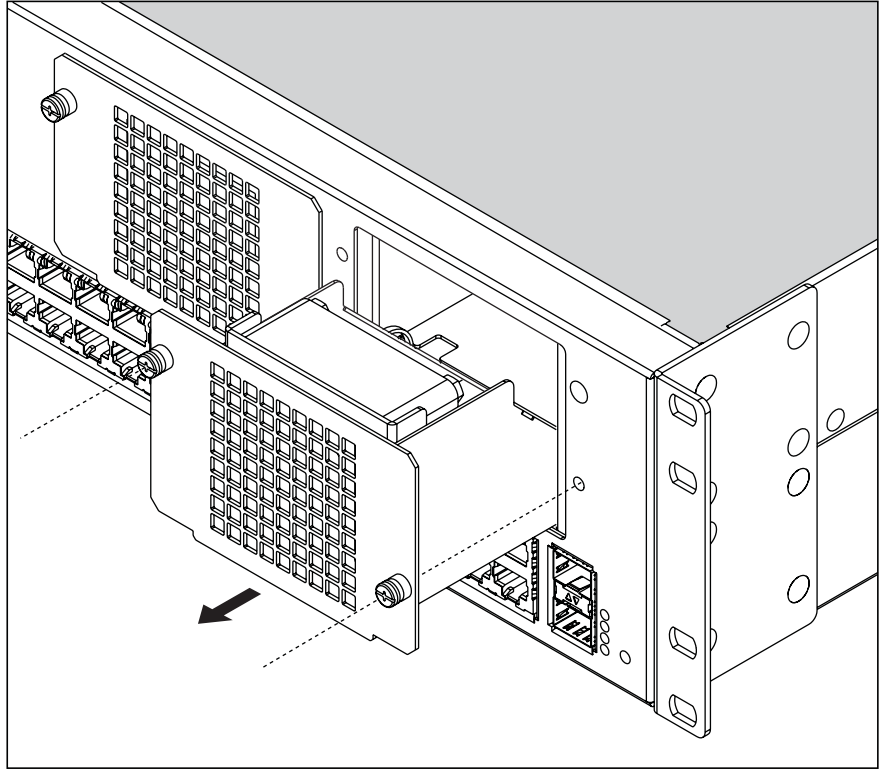

3. Install filters in the replacement fan-only module.

Install an air filter in the replacement FOM. Insert the air filter into the narrow slot between the faceplate of the FOM and the fan. Position the air filter with the plastic frame towards the fan, the quadrafoam towards the faceplate, and the flextab to the top. The air filter should fit snugly.

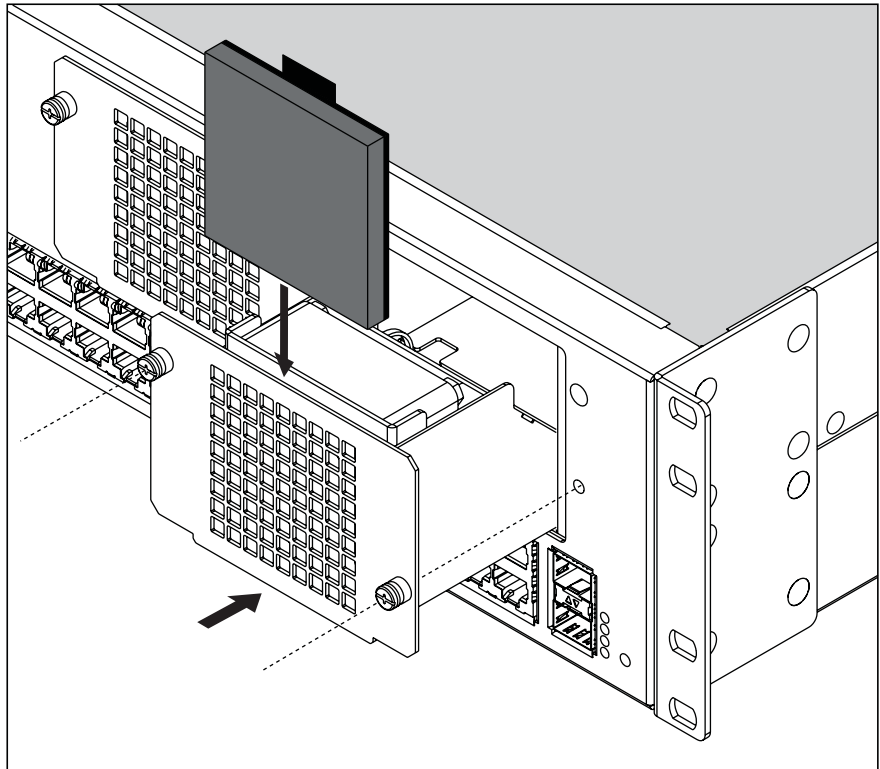

4. Install the replacement fan-only module.



Warning Keep the FOM in straight alignment and insert it slowly. Forcing a misaligned FOM is likely to damage both the chassis and FOM.

Slowly and carefully slide the replacement FOM into the cage, making sure that the air filter and the flextab are clear of any contact points.

Firmly press the FOM until the faceplate engages, or nearly engages, the chassis.

5. Secure the fan-only module.

Tighten the two captive screws on the faceplate of the FOM.

To replace an air filter

1. Remove the current fan-only module from the switch.

Using a flat screwdriver, loosen the captive screws on the faceplate of the FOM, and slide the FOM out of its cage. The internal power connection is quite solid so pull firmly on the captive screws.

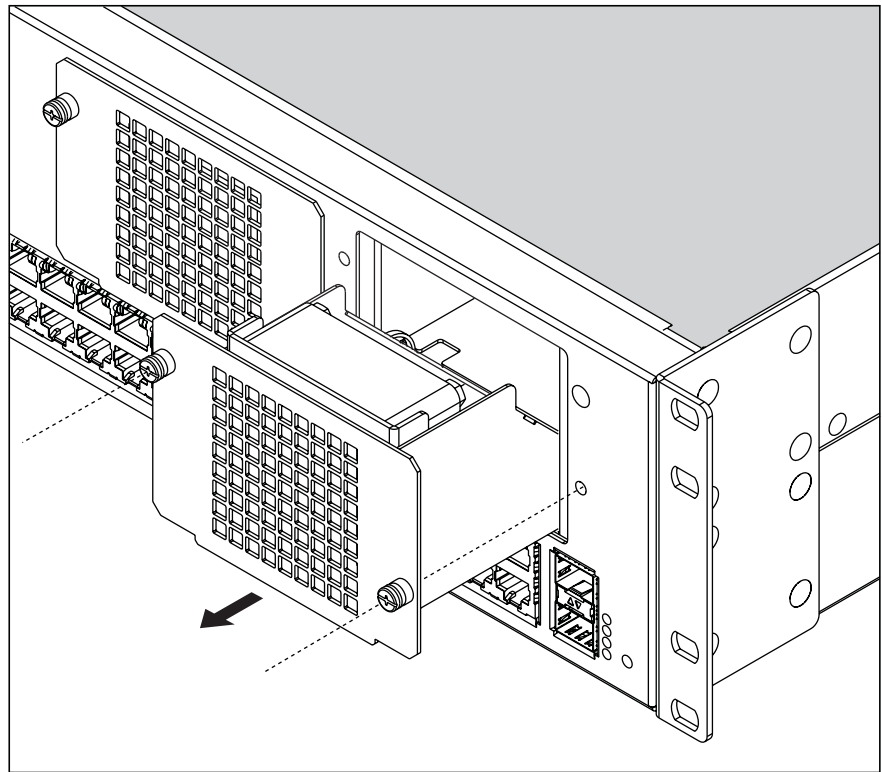

2. Remove the existing fan filter by grasping the flextab at the top and pulling upwards.

3. Install the replacement air filter in the fan-only module.

Insert the air filter into the narrow slot between the faceplate of the FOM and the fan. Position the air filter with the plastic frame towards the fan, the quadrafoam towards the faceplate, and the flextab to the top. The air filter should fit snugly.

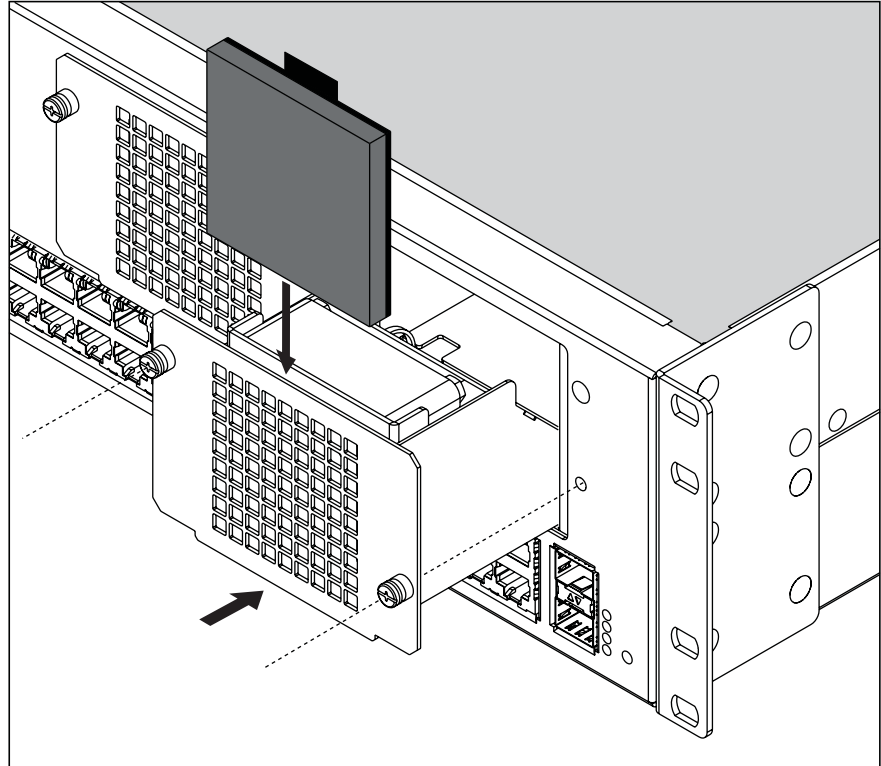

4. Re-install the fan-only module.



Warning Keep the FOM in straight alignment and insert it slowly. Forcing a misaligned FOM is likely to damage both the chassis and FOM.

Slowly and carefully slide the FOM into the cage, making sure that the air filter and the flextab are clear of any contact points.

Firmly press the FOM until the faceplate engages, or nearly engages, the chassis.

5. Secure the fan-only module.

Tighten the two captive screws on the faceplate of the FOM.

AT-TFTP Server

This section explains how to access and use the AT-TFTP Server. You can transfer configuration files as well as download software versions with AT-TFTP Server.

6. If AT-TFTP Server has not been installed, install it now. You can download it from www.alliedtelesis.com/support/software/.

Select AT-TFTP Server from the Start > Programs > Allied Telesis > AT-TFTP Server menu.

7. To set preferences for the AT-TFTP Server, select Options from the File menu to display the Set Options dialog box.

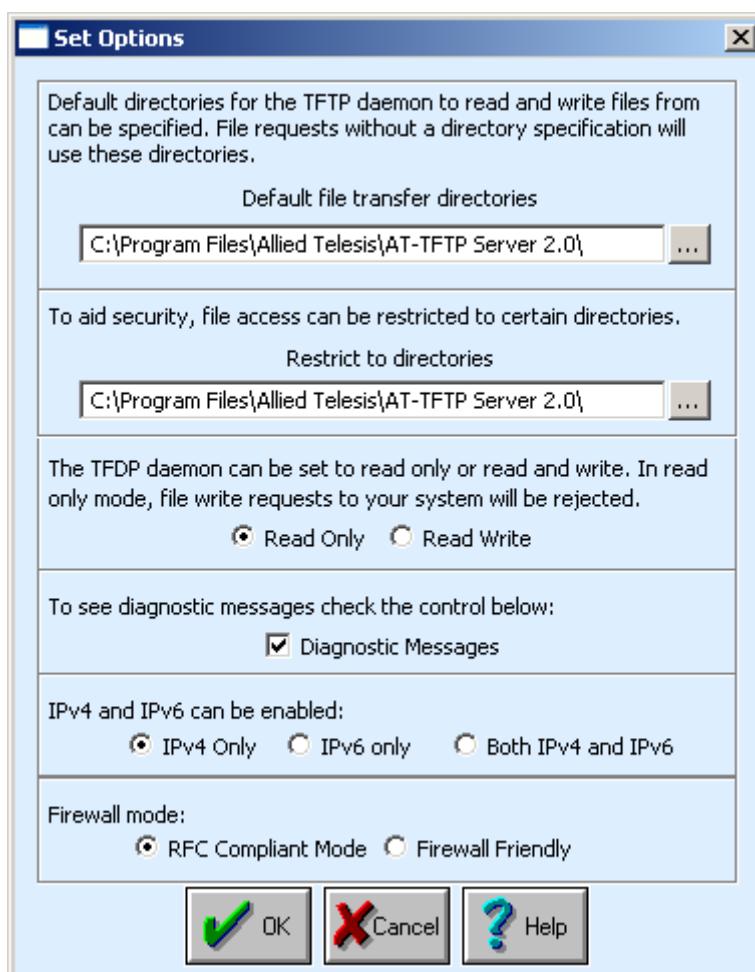

- **Default file transfer directories:** one or more directories that AT-TFTP Server will read from or write to, for requests that do not include a directory specification. Separate multiple directories with semi-colons (“;”).
- **Restrict to directories:** To prevent unauthorised access to private directories, AT-TFTP Server will only use these directories, even if requests explicitly reference other directories. Separate multiple directories with semi-colons (“;”).
- **Read Only/Read Write:** For added security, select “Read only” to prevent AT-TFTP Server writing files to the PC. If you wish to use the PC to archive scripts created using the **create config** command, you must enable the “Read Write” option.

- **Diagnostic Messages:** Check “Diagnostics Messages” to display additional diagnostic messages in the AT-TFTP Server window when debugging file transfers.
 - **IPv4 and IPv6:** Choose whether AT-TFTP Server should respond to TFTP requests received via IPv4 only, IPv6 only, or both IPv4 and IPv6.
 - **Firewall mode:** select “RFC Compliant Mode” to allow multiple files to be transferred simultaneously, or “Firewall Friendly” to force all TFTP traffic to use port 69 as either the source or destination port. This will only allow one file to be transferred at a time.
 - Click the OK button when you finish.
8. To download a file from AT-TFTP Server to your switch, at the switch’s command line interface type the following command:
- ```
load method=tftp file=filename server=ipadd dest=flash
```
- where *filename* is the name of the file to download and *ipadd* is the IP address of the PC running AT-TFTP Server.
9. TFTP requests are logged to the AT-TFTP Server main window. To save a TFTP Server log, select Save As from the File menu.

## Using Windows Terminal and Windows Hyperterminal

You can use a PC running terminal emulation software as the manager console, instead of a terminal. There are many terminal emulation applications available for PCs, but the most readily available are the Terminal and HyperTerminal applications included in Microsoft Windows 98, 2000, and XP Professional. In standard Windows installations, HyperTerminal is available from the Communications submenu.

The key to successful use of terminal emulation software with the switch is to configure the software and switch with matching communications parameters. The following procedure can be applied to most terminal emulation programs. Dialog boxes in the procedure are from Windows 2000 and XP Professional.

### To configure Windows HyperTerminal for 2000 and XP Professional

1. Start the program in Windows by doing one of the following:
  - Select Programs > Accessories > Communications > HyperTerminal.
  - Double-click the Hypertrm.exe icon.
2. In the Connection Description dialog box:
  - Enter a name for the connection, such as Admin.
  - Select an icon from the scrollable list and click the OK button.

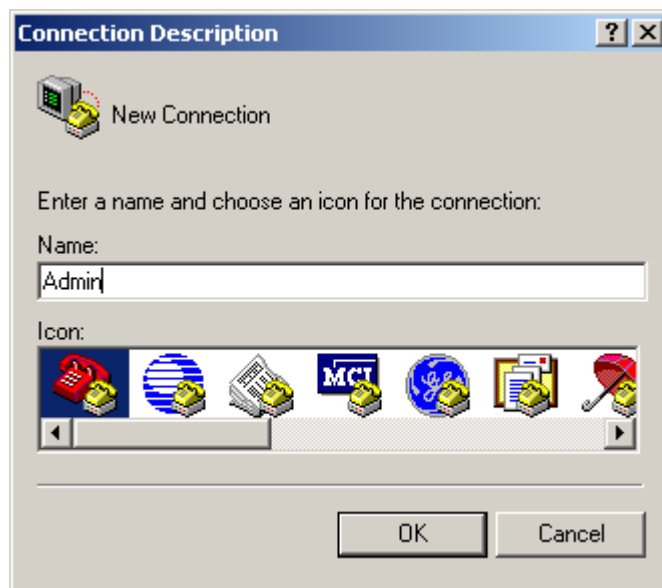

3. In the "Connect using" field on the Connect To dialog box, select the COM port on the PC used to connect to the switch. and click the OK button.



4. In the COM $n$  Properties dialog box, set port parameters as follows, and click the OK button.

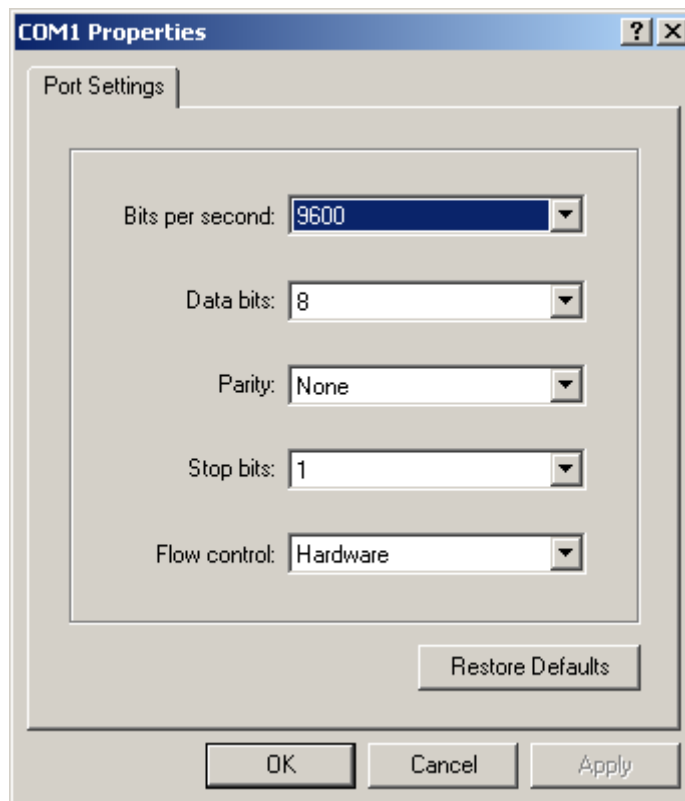

- From the main HyperTerminal window, select Properties from the File menu. Click the Settings tab, and set the Properties dialog box as follows.

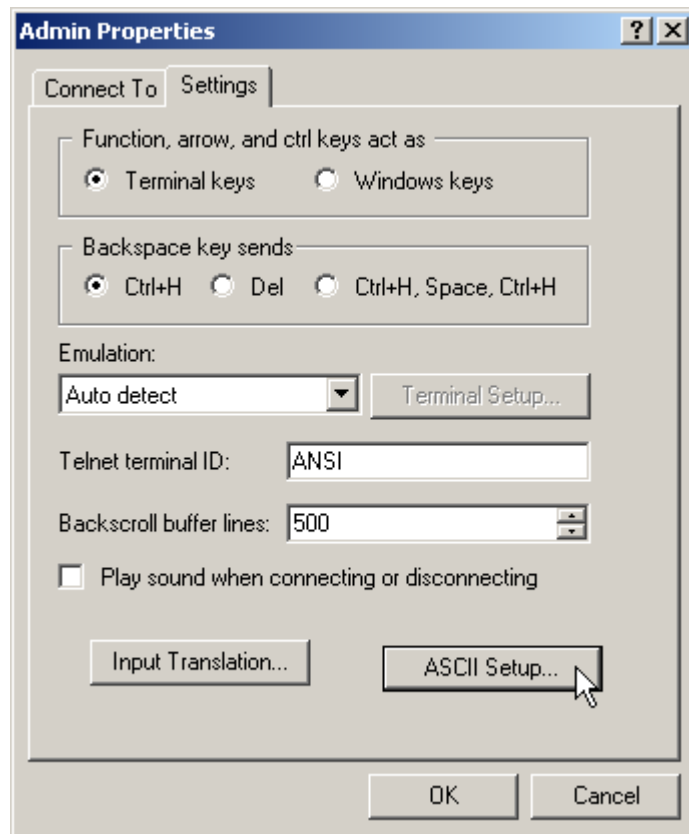

- Click ASCII Setup to display the ASCII Setup dialog box, and ensure the following options are **not** selected:
  - Echo typed characters locally
  - Append line feeds to incoming line ends

Set other parameters as necessary and click the OK buttons on both dialog boxes to close them.

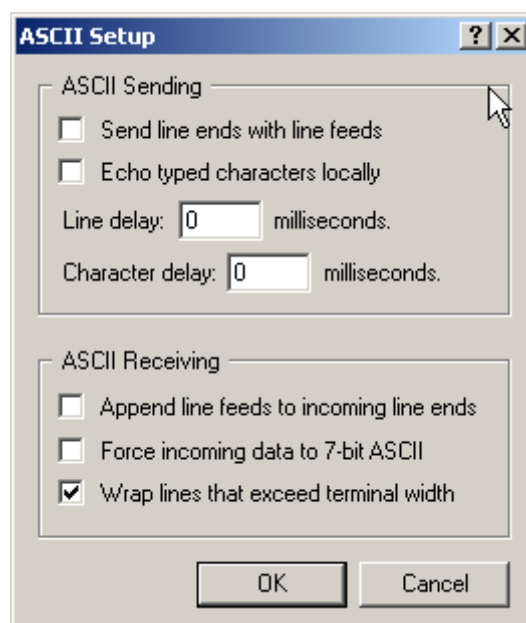

7. Save the current session by selecting Save from the File menu on the main HyperTerminal window. This creates a connection icon with the name you assigned in the HyperTerminal group.

To use the configuration, double-click the connection icon. When the HyperTerminal window appears, press the Enter key several times; the switch's login prompt is then displayed.

## Switch Startup

---

This section describes the login and startup procedures for your Rapier switch. You must go through these procedures to configure the switch and access its full layer 3 switching capabilities.

### To Log In

Using the supplied RS-232 DB9 straight-through cable, connect a terminal or PC to the RS-232 Terminal Port on the front panel of the switch.

Set the communication parameters on your terminal or terminal emulation program to:

- Baud rate: 9600
- Data bits: 8
- Parity: None
- Stop bits: 1
- Flow control: Hardware

See [“Using Windows Terminal and Windows Hyperterminal” on page 39](#) for more information on configuring emulation software.

After the switch has booted, the login prompt appears. If the login prompt does not appear, press the Enter key two or three times.

When the switch boots for the first time it automatically creates an account with manager privileges. The account has the login name “manager” and the password “friend”.

At the login prompt, enter the login name and password.

```
Log in: manager
Password: friend
```

The command prompt appears and you can now configure the switch using the command line interface.



**Warning** Change the password as soon as possible. Leaving the manager account with the default password is a serious security risk. Make sure that you remember the new password as there is no way to retrieve it if it is lost.

Use the following command to change the account password:

```
set password
```

See the *Rapier Series Switch AlliedWare® Operating System Software Reference* for more information on configuring the switch.

## To Access Help

To use online help, the help file must be configured. Use the command:

```
set help=help-filename
```

where *help-filename* is the name of a help file stored in flash.

Help files have an .hlp extension. To see a list of files stored in flash, use the command:

```
show file
```

To display a list of help topics, use the command:

```
help
```

To display help on a specific topic, use the command:

```
help topic
```

where *topic* is the name of a help topic.

You can also type a question mark (?) at the end of a partially completed command to see a list of valid options.

## Startup Procedure

When the switch starts up following either a power cycle or an operator-initiated reboot (using the reset button or **restart** command), it performs a series of self tests and sends messages to the terminal or PC connected to the RS-232 Terminal Port. After the switch successfully starts, a prompt is displayed for you to log in. See the *Getting Started* chapter in the *Rapier Series Switch AlliedWare® Operating System Software Reference* for more information about logging in.

At startup, you can choose to run either the software version stored in the EPROM or the software version in the flash file system specified by the installation parameters previously set using the **set install** command.

All code is executed in system RAM. At power-up, the boot code is loaded from EPROM to RAM. The boot code checks the installation parameters then reloads RAM with the selected *temporary*, *preferred*, or *default* install version stored in the flash file system and runs this code.

The version is uncompressed as it loads to RAM. This may take 10 to 30 seconds. At this point, any required patches are loaded from the flash file system. Any patch is also uncompressed as it loads to RAM. This procedure ensures that the code runs at maximum speed, and allows updates to be made to the code. Updates can be downloaded over the network from a TFTP server and stored in the flash file system until required at power-up.

To download software onto the switch, see the *Managing Configuration Files and Software Versions* chapter in the *Rapier Series Switch AlliedWare® Operating System Software Reference*.

All software, patches, and configuration settings are stored as files in flash memory. Typically, the following files are present in the flash file system:

- The current installed software version. Additional software versions may also be present.
- The current installed patch, if any. Additional patches may also be present.

- The command line help file for the command line interface (CLI). The command help is stored in a separate text file, with extension `.help`. The command help file is loaded with a software version.
- The boot configuration script `boot.cfg`. The boot script contains standard commands executed on startup to configure the switch.
- Additional user-defined configuration scripts containing commands to configure the switch for different functions. These scripts are created using the built-in editor, the **add script** command in the *Scripting* chapter, or the **create config** command in the *Managing Configuration Files and Software Versions* chapter of the *Rapier Series Switch AlliedWare® Operating System Software Reference*.
- Other files required by the system.

Configuration information is stored in flash memory as configuration scripts. These scripts contain standard switch commands. When a configuration command is entered at the command prompt from a terminal, terminal emulation program, or Telnet session, the command alters the dynamic configuration only; this is not saved over a power cycle. To ensure that configuration changes resulting from such commands are retained across a power cycle, the dynamic configuration must be saved as a configuration script, using the **create config** command.

**Startup sequence** When the switch starts up, it performs the following sequence of operations:

1. Perform startup self tests.
2. Load the EPROM version as the install boot into RAM.
3. Prompt for changes to the default startup procedure:
 

```
Force EPROM download (Y)?
```

You can override the default startup procedure. See [“Overrides” on page 44](#).
4. Check the install information to determine which version to load and run. If you do not override the default startup procedure, the install parameters determine which version and patch are loaded and run.
5. Load the required version specified by the install parameters from the flash file system as the main boot.
6. Start the switch.
7. Execute the boot configuration script, if one has been configured. The boot configuration script is either a configuration file set using the **set config** command, or the file `boot.cfg` file, if there is one. For more information about the **set config** command, see the *Managing Configuration Files and Software Versions* chapter of the *Rapier Series Switch AlliedWare® Operating System Software Reference*.

**Overrides** The switch pauses briefly during routine startup messages to display the following prompt:

```
Force EPROM download (Y)?
```

If you do nothing, the normal startup process continues, and switch software is loaded along with a pre-configured startup script. For troubleshooting, you can change the startup process by pressing selected keys ([Table 21 on page 45](#)).

Table 21: Switch startup keystrokes

| Pressing this key... | Forces the switch to...                                                                                                                                           |
|----------------------|-------------------------------------------------------------------------------------------------------------------------------------------------------------------|
| Y                    | Load the version from EPROM, with no patch.                                                                                                                       |
| S                    | Load the version and patch determined by the INSTALL parameters from the flash file system, ignoring any boot script or any previous configuration stored in NVS. |
| Ctrl/D               | Enter diagnostics mode. For more information, see <a href="#">“Diagnostics” on page 49</a> .                                                                      |

**Regular output** [Figure 29](#) shows a typical sequence of messages during the startup process.

Figure 29: Typical switch startup sequence

```

INFO: Self tests beginning.
INFO: RAM test beginning.
PASS: RAM test, 32768k bytes found.
INFO: BBR tests beginning.
PASS: BBR test, 128k bytes found.
INFO: Self tests complete
INFO: Downloading switch software.
Force EPROM download (Y) ?
INFO: Initial download succeeded
INFO: Executing configuration script <boot.cfg>
INFO: Switch startup complete

Manager >

```

**Types of messages** [Table 22](#) explains the types of messages that the switch generates during startup.

Table 22: Switch startup message types

| Message | Meaning                                                                                                  |
|---------|----------------------------------------------------------------------------------------------------------|
| INFO    | An action will be taken by the system.                                                                   |
| PASS    | A test has been completed successfully.                                                                  |
| ERROR   | An error message that a test has failed, but the system continues to operate.                            |
| FAIL    | An error message that a fatal error condition has caused the system to halt in an unrecoverable fashion. |

**Startup messages** Table 23 lists the possible startup messages and their meanings.

Table 23: Switch startup messages

| Message                                                                                                                                 | Description                                                                                                                                                                                                                                                                                                  |
|-----------------------------------------------------------------------------------------------------------------------------------------|--------------------------------------------------------------------------------------------------------------------------------------------------------------------------------------------------------------------------------------------------------------------------------------------------------------|
| INFO: Self tests beginning.                                                                                                             | Code loader tests are about to begin.                                                                                                                                                                                                                                                                        |
| INFO: RAM test beginning.                                                                                                               | RAM tests are about to begin.                                                                                                                                                                                                                                                                                |
| PASS: RAM test, 32768k bytes found.                                                                                                     | RAM test passed and the switch is using the indicated amount of memory.                                                                                                                                                                                                                                      |
| ERROR: RAM test <i>test-number</i> .<br>Error address = <i>address</i> .<br>For example:<br>ERROR: RAM test 5. Error address = 00345678 | The given RAM test failed at the given address, which means that the memory system is faulty. The test repeats until it passes, so a number of messages like this may appear. If the error continues, contact your authorised Allied Telesis distributor or reseller.                                        |
| INFO: BBR tests beginning.                                                                                                              | BBR battery tests are about to begin.                                                                                                                                                                                                                                                                        |
| PASS: BBR test. Battery OK.                                                                                                             | BBR battery tests passed.                                                                                                                                                                                                                                                                                    |
| ERROR: BBR Battery low.                                                                                                                 | BBR battery test failed, indicating that the battery is running low. The BBR battery must be replaced. Contact your authorised Allied Telesis distributor or reseller.                                                                                                                                       |
| PASS: BBR test, 256k bytes found.                                                                                                       | BBR size/location test passed with the indicated amount of BBR found.                                                                                                                                                                                                                                        |
| FAIL: BBR test. Error address = <i>address</i> .                                                                                        | The BBR size/location test failed at the given location. The test at this location failed, indicating the end of memory, but a valid location was discovered in the 255 long words following this location. The BBR system must be replaced. Contact your authorised Allied Telesis distributor or reseller. |
| FAIL: BBR test, only 16k bytes found.                                                                                                   | The BBR size/location test completed, but only the displayed amount of memory was found. This amount is less than the minimum required to run the switch software.                                                                                                                                           |
| INFO: Self tests complete.                                                                                                              | The startup tests have finished.                                                                                                                                                                                                                                                                             |
| INFO: Downloading switch software.                                                                                                      | The process of downloading the switch software and vector table from ROM is about to begin.                                                                                                                                                                                                                  |
| ERROR: Code load retried.<br>FAIL: Code load failed.                                                                                    | Loading code from ROM to RAM failed. The load is retried a number of times, and the error message is displayed each time it fails. The FAIL message is displayed if the maximum number of attempts is reached.                                                                                               |
| INFO: Initial download succeeded.                                                                                                       | Startup tests and download are complete, and the switch software is about to be started. The release is now decompressed. This may take a few seconds.                                                                                                                                                       |
| INFO: Downloading compressed release. This may take up to 1 minute...                                                                   | The main switch software is decompressed before being loaded into RAM.                                                                                                                                                                                                                                       |
| INFO: Loading software into memory. This may take up to 1 minute...                                                                     |                                                                                                                                                                                                                                                                                                              |
| INFO: Executing configuration script <i>script-name</i>                                                                                 | Configuration commands in the given script are being executed. If the script has an error, appropriate error messages are displayed.                                                                                                                                                                         |

Table 23: Switch startup messages (continued)

| Message                                                                                                                                                   | Description                                                                                                                                                     |
|-----------------------------------------------------------------------------------------------------------------------------------------------------------|-----------------------------------------------------------------------------------------------------------------------------------------------------------------|
| INFO: switch startup complete.                                                                                                                            | The startup process is complete and the switch is now performing switching operations.                                                                          |
| FAIL: Unexpected exception. Offset = <i>number</i> , Addr = <i>address</i> .<br>For example:<br>FAIL: Unexpected exception. Offset = 40, Addr = 0100045e. | An unexpected exception occurred during the startup process. Contact your authorised Allied Telesis distributor or reseller.                                    |
| INFO: Initialising Flash (This may take some time)                                                                                                        | The flash file system is corrupt and the switch is now re-initialising the flash device. The process will take at least 4 minutes, depending on the switch.     |
| INFO: IGMP Snooping is activated.                                                                                                                         | IGMP snooping has been enabled.                                                                                                                                 |
| INFO: IGMP packet trapping is active for IGMP snooping, L3FILT is activated                                                                               | IGMP snooping has been enabled.                                                                                                                                 |
| WARNING: IGMP packet trapping not active, failed to create HW filters.                                                                                    | IGMP snooping could not be activated on the switch ports. This may indicate a hardware failure. Contact your authorised Allied Telesis distributor or reseller. |
| ERR: Error ( <i>number</i> ): Parameter " <i>keyword</i> " not recognised.                                                                                | The configuration file contains commands not recognised by the software version that is loaded.                                                                 |

## Test Facility

The Test Facility is a hardware test tool built into the switch software. Its primary function is to validate that there are no hardware problems after installation of the switch or expansion options. You can also use it as a troubleshooting tool, but it is just one of many such tools. For more information about the Test Facility, see the *Test Facility* chapter in the *Rapier Series Switch AlliedWare® Operating System Software Reference*.

Testing should not be performed while the switch is operational as the presence of a loopback plug may cause feedback of network traffic. Also, any interfaces being tested are dedicated to the Test Facility. Before you use the Test Facility, disable configurations by using the **set configuration=none** command, and restart or reboot the switch.

Rapier switches and their expansion options support a wide range of interface types, including Ethernet, asynchronous, synchronous, Basic Rate ISDN and Primary Rate ISDN. Each interface type, except Ethernet interfaces on the AT-AR026 PIC, can be tested independently using the Test Facility software.

Most tests also require the use of a loopback plug. For more information on loopback plugs, see [“Loopback Plugs for Testing Switch Interfaces” on page 30](#).

To enable testing on an interface, use the command:

```
enable test interface=interface
```

Tests run for 4 minutes. To display progress and results, use the command:

```
show test
```

This produces a display similar that shown in [Figure 30](#).

Figure 30: Example output from the **show test** command

| Board  | ID  | Bay | Board Name          | Host Id | Rev  | Serial number |
|--------|-----|-----|---------------------|---------|------|---------------|
| Base   | 114 |     | AT-RP24i Rapier 24i | 0       | M1-0 | 6845822       |
| Uplink | 88  | 1   | AT-A35SX/SC-00      |         | P1-0 | 14269019      |

| Interface | State   | Result | Type | Duration (minutes) | Details Data( %OK ) | Control |
|-----------|---------|--------|------|--------------------|---------------------|---------|
| port1     | no test | -      | -    | -                  | -                   | -       |
| port2     | no test | -      | -    | -                  | -                   | -       |
| port3     | no test | -      | -    | -                  | -                   | -       |
| port4     | no test | -      | -    | -                  | -                   | -       |
| port5     | no test | -      | -    | -                  | -                   | -       |
| port6     | no test | -      | -    | -                  | -                   | -       |
| port7     | no test | -      | -    | -                  | -                   | -       |
| .         |         |        |      |                    |                     |         |
| .         |         |        |      |                    |                     |         |
| .         |         |        |      |                    |                     |         |
| port23    | no test | -      | -    | -                  | -                   | -       |
| port24    | no test | -      | -    | -                  | -                   | -       |
| port26    | no test | -      | -    | -                  | -                   | -       |
| asyn0     | no test | -      | -    | -                  | -                   | -       |

**Important** If a test fails, contact your authorised Allied Telesis distributor or reseller.

**10/100 switch ports** A loopback plug is required to test 10/100MB switch ports. See [“Loopback Plugs for Testing Switch Interfaces” on page 30](#) for details of how to make a loopback plug. To start testing on a switch port interface, use the command:

```
enable test int=portn
```

where *n* is the switch port number.

**Gigabit switch ports** To test a Gigabit switch port, connect two ports using a crossover or straight-through cable, and enable testing on all ports, using the command:

```
enable test int=all
```

**NSM and PIC interfaces** For information about testing NSM interfaces, see the *Network Service Module Hardware Reference*. For information about testing PIC interfaces, see the *Port Interface Card Hardware Reference*. You can download these documents from [www.alliedtelesis.com/support/software](http://www.alliedtelesis.com/support/software).

## Diagnostics

---

The switch software includes a set of diagnostic programs that perform basic checks of all system components. These diagnostics do not run with the normal operating code and require that the system be totally dedicated to their use. The switch does **not** perform normal switching operations when diagnostics are running.

Diagnostics are designed to be run by service personnel only. This section is **not** intended as a guide to the diagnostics software. Detailed knowledge of how the switch hardware functions is necessary in order to effectively use these diagnostic programs. For more information, contact your authorised Allied Telesis distributor or reseller.

The diagnostics programs do not perform checks on AT-AR026 PICs.

### Enabling diagnostics mode

1. Connect a terminal to the console port.

Using an RS-232 DB9 straight-through cable, connect a terminal or a PC running terminal emulation software to the console port (RS-232 Terminal Port). For more information about terminal cables, see [“Terminal and Modem Cables” on page 28](#). For more information about using terminal emulation software, see [“Using Windows Terminal and Windows Hyperterminal” on page 39](#).

Set the terminal communications parameters to:

- 9600 bps
- 8 data bits
- 1 stop bit
- No parity
- Hardware flow control

2. Restart the switch.

Restart the switch, either by using a pen or pencil to operate the recessed reset button on the front panel, or by using the terminal to log in and enter the command:

```
restart reboot
```

See [“To Log In” on page 42](#) for more information on how to log in.

3. Enable diagnostics mode during startup.

During the switch startup process, at the prompt:

```
Force EPROM download (Y)?
```

press **Ctrl+D** on the terminal to enter diagnostics mode. A menu is displayed on the terminal ([Figure 31 on page 50](#)). This can be used to check that the terminal is correctly connected.

Figure 31: Rapier Switch diagnostics banner page

```

* * * Diagnostic Mode * * *

version 16-Mar-98

Main Menu:
0. Restart
1. Full RAM test
2. ROM checksum test
3. Full FLASH test
4. Totally Erase FLASH
5. Battery backed RAM test
Enter selection ==>

```

### Running a diagnostic program

To run a diagnostic program, enter the corresponding number or letter. There are several sub-menus to cover all the available options. [Table 24](#) lists the control keys for diagnostic operations.

Table 24: Basic commands for running the diagnostics

| Key | Function                                              |
|-----|-------------------------------------------------------|
| Q   | Quits any running tests and displays the banner page. |
| S   | Prints a summary of test results so far.              |

A reasonable understanding of the systems structure is needed to operate diagnostics and interpret the results.

### Restoring normal operation

To restore the switch to normal operation, use a pen or pencil to operate the recessed reset button on the front panel, or press "0" (zero) to restart.

# Troubleshooting

---

This section provides information on how to troubleshoot the Rapier switch to resolve the following basic problems:

- **L/A LED on a port is off**
- **Power LED is off**
- **Fault LED is on**

## What to check first

- Make sure the power cord is securely connected.
- Check that the power supply voltage is stable.
- Check that the correct data cables are being used and that their connections are secure.
- Make sure that other network devices are working properly.
- Use the **show install** command to check that the latest software version is loaded. See the *Rapier Series Switch AlliedWare<sup>®</sup> Operating System Software Reference* for more information about obtaining the latest software version.
- If the switch is malfunctioning, reboot it by pressing the recessed Reset button or entering the **restart reboot** command. Alternatively, power off and on the switch by disconnecting and reconnecting the main power supply including, if connected, the RPS power.

## L/A LED on a port is off

This can indicate:

- A loose data cable.
- The device at the other end of the connection is not working properly or is turned off.
- The data cable is not wired correctly.
- The network administrator has manually disabled the port through the software.
- The port's selected transmission mode does not match that of the attached device.

Perform the following steps in sequence:

1. Make sure the data cable connections are secure.
2. Make sure the device at the other end of the connection is switched on and working properly.
3. Check that the data cable is wired correctly.
4. If you can, log in and check the port status. See [“To Log In” on page 42](#) for more information on how to log in.
5. If the port is enabled, make sure the transmission speed matches that of the connected device (auto-negotiating, full or half-duplex).



---

*If the port is disabled, someone has used the software to manually disable it. You should find out why the port was disabled before enabling it.*

---

**Power LED is off** This can indicate:

- A loose power cord or DC power crimp
- A power supply failure

Perform the following steps in sequence:

1. Check that the power cord connections are secure.
2. Check that all switches and circuit protection devices are in the ON position.
3. Ensure that the supply voltage is within the operational range—see “Power supply” on page 6 for the correct operating voltages.

**Fault LED is on** This can indicate:

- There is a problem with the switch or RPS PSU.
- The switch or management software is malfunctioning.
- A hardware fault is preventing switch startup.

Perform the following steps in sequence:

1. Check [Table 1 on page 14](#) or [Table 2 on page 15](#) for descriptions and explanations of LED flashing sequences.
2. Reset the switch by pressing the recessed RESET button on the front panel.
3. If you were attempting to download software or manage the switch via the RS-232 terminal Port, check that connections between the Terminal Port and local terminal or PC are secure.

If you cannot access the switch’s software because of a faulty RS-232 Terminal Port connection, you can still manage the switch via Telnet or SNMP until the problem is fixed.

4. Unplug the switch and then plug it in again. If present, you will also have to disconnect and reconnect the RPS unit.
5. Download the latest software version. See the *Rapier Series Switch AlliedWare® Operating System Software Reference* for more information on how to obtain the latest software version release.

**Additional resources** Other sources of useful troubleshooting information are:

- [www.alliedtelesis.com/support/software](http://www.alliedtelesis.com/support/software)
- The *Test Facility* chapter in the *Rapier Series Switch AlliedWare® Operating System Software Reference*
- How-To Notes from [www.alliedtelesis.com/resources/literature/howto.aspx](http://www.alliedtelesis.com/resources/literature/howto.aspx)

## Obtaining Documentation and Resources

**Document set** The complete document set for Rapier Series switches includes the following:

- The *Rapier i Series Switch Safety and Statutory Information* booklet, which contains safety information for all Rapier switches except the Rapier 48w
- The *Rapier Series Switch Quick Install Guide*, which describes how to install all Rapier switches except the Rapier 48w and 48w-B
- The *Rapier 48w Switch Installation and Safety Guide*, which describes how to install the AC and DC models of Rapier 48w and 48w-B switches and includes important safety and statutory information
- The *Rapier 48w Switch Removable Fan Installation Guide*, which describes how to install AT-FAN04 fan units in the Rapier 48w and 48w-B switches
- The *Rapier Series Switch Hardware Reference*, which contains detailed information on the hardware features of all Rapier Series switches
- The *Rapier Series Switch AlliedWare® Operating System Software Reference*, which contains detailed information on configuring the switch and its software
- The *Network Service Module Installation and Safety Guide*, which describes how to install a Network Service Module
- The *Network Service Module Hardware Reference*, which contains detailed information on the hardware features of Network Service Modules
- The *Port Interface Card Installation and Safety Guide*, which describes how to install a Port Interface Card
- The *Port Interface Card Hardware Reference*, which contains detailed information on the hardware features of Port Interface Cards
- The *Uplink Module Installation and Safety Guide*, which describes how to install an uplink module
- The *Uplink Module Hardware Reference*, which contains detailed information on the hardware features of uplink modules

You can download these documents and updates from [www.alliedtelesis.com/support/software](http://www.alliedtelesis.com/support/software).

You need Adobe® Acrobat® Reader® to view, search, or print these documents. You can download it from [www.adobe.com](http://www.adobe.com).

**Other resources** How-To Notes describe a range of standard Allied Telesis solutions, and include technical tips and guides to configuring specific hardware and software features. You can download the latest How-To Notes from [www.alliedtelesis.com/resources/literature/howto.aspx](http://www.alliedtelesis.com/resources/literature/howto.aspx).

MIBs supported by Allied Telesis products can be downloaded from [www.alliedtelesis.com/support/software](http://www.alliedtelesis.com/support/software).

Microsoft® Visio® stencils for Allied Telesis products can be downloaded from [www.alliedtelesis.com/resources/images/visio.aspx](http://www.alliedtelesis.com/resources/images/visio.aspx).

AT-TFTP Server for Windows is a TFTP (*Trivial File Transfer Protocol*) server for transferring software versions, configuration scripts and other files between a PC and the switch. You download AT-TFTP Server from [www.alliedtelesis.com/support/software](http://www.alliedtelesis.com/support/software).

**CD-ROM** Some products ship with a Documentation and Tools CD-ROM, which includes:

- the complete document set
- Adobe® Acrobat® Reader®
- AT-TFTP Server
- Supported MIBs
- How-To Notes, white papers, Microsoft® Visio® stencils and other resources
- Tryouts of networking software

**Contacting us** With locations covering all of the established markets in North America, Latin America, Europe, Asia, and the Pacific, Allied Telesis provides localized sales and technical support worldwide. To find the representative nearest you, visit us on the Web at [www.alliedtelesis.com](http://www.alliedtelesis.com).