

Removable Power Supply and Fan Installation Guide



- AT-PWR01
- AT-PWR02
- AT-PWR05
- AT-FAN01
- AT-FAN03

Removable Power Supply and Fan Installation Guide

AT-PWR01

AT-PWR02

AT-PWR05

AT-FAN01

AT-FAN03

Download the complete document set from
www.alliedtelesis.com/support/software

Removable Power Supply and Fan Installation Guide Document Number C613-04057-00 REV R

© 2009 Allied Telesis, Inc. All rights reserved. No part of this publication may be reproduced without prior written permission from Allied Telesis, Inc.

Allied Telesis, Inc. reserves the right to change specifications and other information in this document without prior written notice. The information provided herein is subject to change without notice. In no event shall Allied Telesis, Inc. be liable for any incidental, special, indirect, or consequential damages whatsoever, including but not limited to lost profits, arising out of or related to this manual or the information contained herein, even if Allied Telesis, Inc. has been advised of, known, or should have known, the possibility of such damages.

Allied Telesis, AlliedWare, AlliedWare Plus, and SwitchBlade are trademarks or registered trademarks in the United States and elsewhere of Allied Telesis, Inc. Adobe, Acrobat, and Reader are either registered trademarks or trademarks of Adobe Systems Incorporated in the United States and/or other countries. Microsoft and Visio are either registered trademarks or trademarks of Microsoft Corporation in the United States and/or other countries. Additional brands, names and products mentioned herein may be trademarks of their respective companies.

Contents

About this Guide	4
Compatible Switches	4
Package Contents	5
Installing a Power Supply Unit or Fan	6
Connecting an AC power supply	9
Connecting a PWR01 DC power supply	12
Connecting a PWR05 DC power supply	14
Checking LEDs	16
Removing a Power Supply Unit or Fan	19
Troubleshooting	22
Obtaining Documentation and Resources	23
Standards	25
EC Declaration of Conformity	26

About this Guide

This Installation Guide describes how to install the following PSUs and fans:

- AT-PWR01 PSU, either AC or DC power supply unit
- AT-PWR02 PSU, AC only
- AT-PWR05 PSU, either AC or DC power supply unit
- AT-FAN01, fan-only module
- AT-FAN03, chassis fan module

Compatible Switches

The following table shows which models of PSUs and fans are appropriate for individual switches.

Switch	PWR01	PWR02	PWR05	FAN01	FAN03
AT-8948	✓			✓	
x900-48FE	✓			✓	
x900-48FS		✓		✓	
AT-9924T	✓			✓	
AT-9924SP	✓			✓	
AT-9924Ts	✓			✓	
x900-24XT	✓			✓	
x900-24XT-N	✓			✓	
x900-24XS	✓			✓	
SwitchBlade® x908			✓		✓

You can download complete documentation for these switches from www.alliedtelesis.com/support/software. For more information about the documentation and other resources, see “[Obtaining Documentation and Resources](#)” on page 23.

Package Contents

Depending on the model, switches are shipped with a single supply unit (PSU), either AC or DC. Some models also have fan-only modules (FOM), chassis fan modules, or blanking plates.

- The AT-8948, AT-9924Ts, x900-24XT, x900-24XT-N, and x900-24XS switches have a PSU and a FOM installed.
- The x900-48FE, x900-48FS, AT-9924T, and AT-9924SP switches have a PSU and a blanking plate installed.
- The SwitchBlade® x908 is shipped with dual chassis fan modules and blanking plates, but no PSUs.

The following items are included with each factory-installed PSU. Contact your authorised Allied Telesis distributor or reseller if any are damaged or missing.

- one AC power cable (AC models)
- one power cable retaining clip (AC models)
- one warranty card

The following items are included with PSUs when purchased separately:

- one AC power cable (AC models)
- one power cable retaining clip (PWR01 and PWR02 AC models only)
- one clip-on ferrite core (PWR05 AC model only)
- one DC power cable (PWR05 DC model only - requiring termination to a 48V DC power supply by a suitably qualified person)
- this Installation Guide
- one warranty card

The following items are included with fans when purchased separately:

- this Installation Guide
- one warranty card

Installing a Power Supply Unit or Fan

Use these instructions to install PSUs, chassis fan modules and FOMs.

- Do not combine AC and DC PSUs in the same switch.
- Do not combine PWR01 and PWR02 PSUs in the same switch.

Before you begin

- Read the safety information for the switch.

Safety information is in the *x900 Series Switch and SwitchBlade® x908 Installation and Safety Guide*. You can download this document from www.alliedtelesis.com/support/software.

- Gather necessary tools and equipment.

You will need an appropriate flat-bladed or Phillips (#1) screwdriver to tighten or loosen the captive screws.

- Verify the package contents if you have not already done so.

See “[Package Contents](#)” on [page 5](#). Contact your authorised Allied Telesis distributor or reseller if items are damaged or missing.

- Remove the unit from its packing material in an anti-static environment.



Caution Follow correct anti-static procedures. Failure to do so could damage the PSU, fan, or switch. If you are unsure about correct procedures, contact your authorised Allied Telesis distributor or reseller.



Caution When adding or replacing power supplies, keep your hands and fingers out of the power supply bays. After installing a PWR05 power supply, use a screwdriver to tighten the captive screw such that a screwdriver will be required to remove the PSU at a later date.

Installing a PWR01, PWR02, or FAN01



1. If there is a PSU, fan or blanking plate in the bay you wish to install the unit, first remove the old unit, following the steps described in section [“Removing a Power Supply Unit or Fan”](#) on page 19.
2. Insert the new PSU or fan unit, and carefully slide it into the bay.
Insert it slowly, being sure to keep it straight. Firmly press the unit until the faceplate engages, or nearly engages, the chassis. Forcing a misaligned unit into the bay is likely to damage both the unit and chassis.

Note that when you have only one PSU installed in the AT-9924T and AT-9924SP switches, it must be installed in bay 2 to optimise cooling.
3. Secure the unit in the switch by tightening the captive screws on the faceplate.

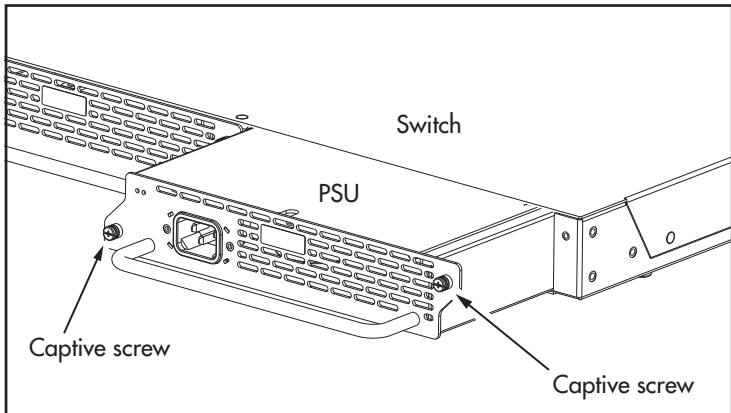

Installing a PWR05 or FAN03



1. If there is a PSU, fan or blanking plate in the bay you wish to install the unit, first remove the old unit, following the steps described in section [“Removing a Power Supply Unit or Fan”](#) on page 19.

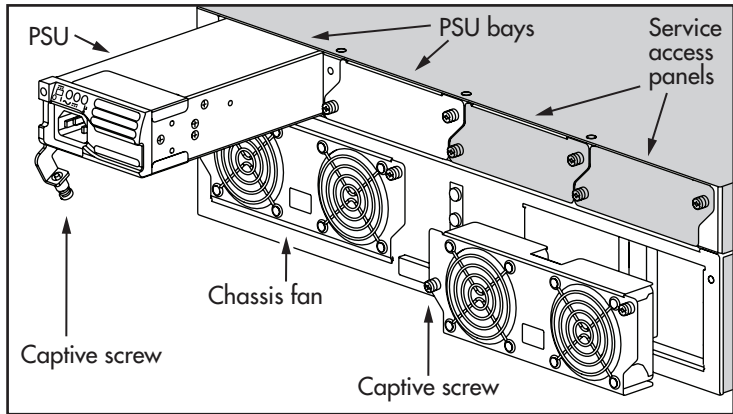

2. Insert the new PSU or chassis fan module, and carefully slide it into the bay.
If you are installing a PSU, unlock the latch on the PSU first by loosening the captive screw.
Insert the PSU or fan module slowly, being sure to keep it straight. Firmly press the unit until the faceplate engages, or nearly engages, the chassis.
Forcing a misaligned unit into the bay may damage both the unit and chassis.
3. Secure the unit in the switch by tightening the captive screw(s) on the faceplate. On the PWR05, use a screwdriver to tighten the captive screw such that a screwdriver will be required to remove the PSU at a later date.

Connecting an AC power supply

Follow these instructions to connect an AT-PWR01, AT-PWR02, or AT-PWR05 AC PSU to an AC power supply:



Warning The AT-PWR01 AC PSU has a fuse rating of 250VAC, 5A for FH101 and FH102.



Warning The AT-PWR01 AC PSU has double pole/neutral fusing. Electric shock is possible since there are dual primary fuses, one on the phase circuit and one on the neutral circuit. If the neutral opens, the phase may still be live.



Warning When x900-24 units are connected with VCS stacking cables (XEM-STK-CBL) ensure that all the PSUs are appropriately grounded. This is to avoid large circulating ground currents that could damage the stacking cables. To achieve this ensure that:

- AT-PWR01 AC is grounded by the 3-pin AC power connector
- All grounding points are at the same ground level. That is, all power connectors share a common power distribution unit.



Warning For SwitchBlade x908 units with AC PSUs, the grounding stud on the rear of the device is provided for situations where an additional ground is required. The device must be powered from a grounded 3 wire AC source via the AC power cable and connector.



Warning When SwitchBlade x908 units are connected with VCS stacking cables (either HS-STK-CBL or XEM-STK-CBL), each individual stack member chassis must be additionally grounded by using the rear grounding-terminal on each device. In order to avoid large circulating ground currents, the wires of each grounding cable must be 18 AWG (0.8mm²) or thicker.

Connecting a PWR01 or PWR02

1. Plug the supplied AC power cable into the power inlet on the PSU and attach the retaining clip.
2. Connect the power cable to the main power source.
3. The PSU LED on the front panel of the switch lights green. If the LED does not light, refer to the Hardware Reference for troubleshooting information.

Connecting a PWR05 (AC version only)

The rear grounding-terminal is not necessary for the SwitchBlade x908 when using AC PSUs because the chassis is grounded through the power cable.

1. Form a loop in the supplied AC power cable at the PSU end and clip the ferrite core over the looped cable, as shown in the following illustration. This keeps the ferrite core in its correct position, close to the PSU.

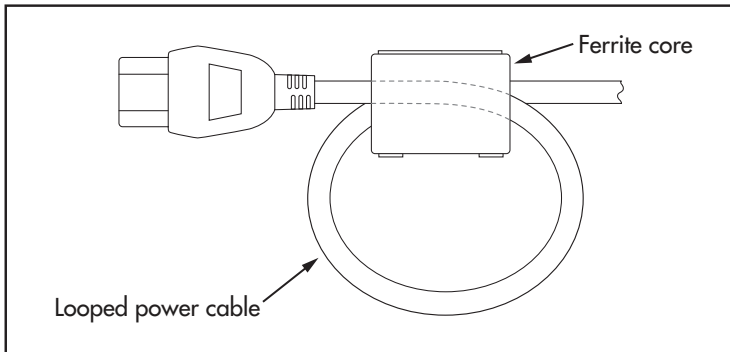

2. Plug the AC power cable into the power inlet on the PSU.
3. Connect the power cable to the main power source.
4. Check that the Run/Standby switch is set to the Run position (I). Both the AC IN and DC OUT LEDs should be lit.

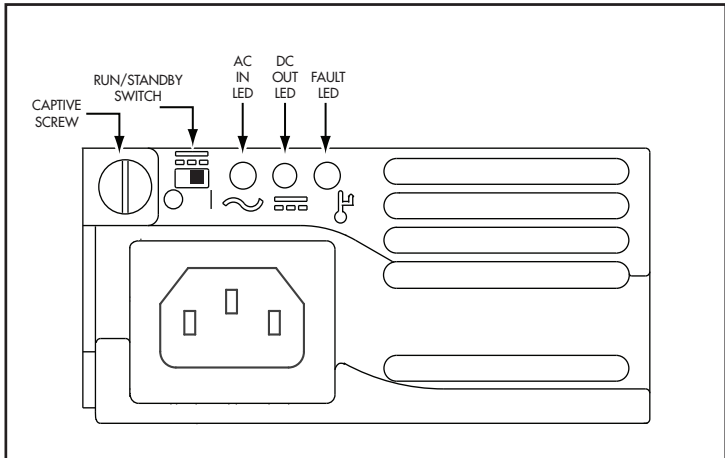

Note that when the Run/Standby switch is set to the Standby position (O), the AC IN LED lights and the fan spins, but the DC OUT LED does not light and the PSU **does not** deliver power to the device.

5. The PSU LED on the front panel of the switch lights green. If the LED does not light green, check the Run/Standby switch. See the Hardware Reference for more troubleshooting information.

Connecting a PWR01 DC power supply

Follow these instructions to connect an AT-PWR01 DC PSU to a DC power supply. Only trained and qualified personnel should connect a DC power supply.

You need an appropriate DC power source, DC supply cable, ring connectors, a crimp tool and an appropriate screwdriver to tighten the terminal screws.

For centralised DC power connection, the switch should be installed in **restricted access areas only** (such as dedicated equipment rooms or equipment closets) in accordance with Articles 110-16, 110-17, and 110-18 of the National Electrical Code, ANSI/NFPA 70.

Power supply specifications:

- functional range 40 to 60V, 48V nominal
- supports either positive grounded or negative grounded operation
- a 15Amp certified/listed circuit breaker is required for circuit protection

Supply cable specifications:

- tray cable should be UL listed Type TC tray cable (or equivalent)
- three-core cable is required
- minimum core size: 3.3mm^2 (12 AWG) high strand count copper wire
- minimum cable rating: 600V, 90 degrees C



Warning Disconnect the power supply cable before starting this procedure.

1. Remove the transparent protective terminal cover.
2. Strip the supply cable wires to expose 7.5mm (0.31 in.) of bare conductor. Terminate the wire with a nylon insulated solderless ring tongue terminal, JST FN5.5-5 or equivalent, using a crimp tool.
3. Connect the ground wire to the ground terminal. Use the diagram on the rear panel of the switch to identify terminals. Tighten the terminal to between 2.4 and 4.0 Nm (21.3 and 35.4 lbf in).



Warning When x900-24 units are connected with VCS stacking cables (XEM-STK-CBL) ensure that all the PSUs are appropriately grounded. This is to avoid large circulating ground currents that could damage the stacking cables. To achieve this ensure that:

- AT-PWR01 DC is grounded at the GND terminal. In order to avoid large circulating ground currents, the wires of each grounding cable must be 18 AWG (0.8mm^2) or thicker.

- All grounding points are at the same ground level. That is, all power connectors share a common power distribution unit.



Warning When mounting one or two AT-PWR01 DC PSUs to a grounded rack, ensure that the ground level of the rack and the DC power connector are the same.

4. Connect the positive feed to the + (positive) terminal and the negative feed to the - (negative) terminal. Tighten the terminals to between 2.4 and 4.0Nm (21.3 and 35.4 lbf in).

Note that the DC return input terminal must be connected as an Isolated DC return (DC-I).



Warning In order to avoid damaging the PSU, make sure that the PSU terminals are wired to the correct polarity.

5. Ensure that there are no exposed cable strands.
6. Replace the cover. You **must** replace the transparent plastic terminal cover before continuing.
7. Secure the supply cable to the rack framework or a similar object to ensure that connections are isolated from any force applied to the cable.
8. Ensure that the circuit breaker for the supply circuit and the Run/Standby switch on the PSU are **off**. Press and release the Run/Standby switch so that it is not pushed in (which is the Off position).
9. Connect the supply cable wires to the circuit breaker.
10. Turn on the PSU by pushing in the Run/Standby switch.
11. Confirm that the switch is receiving power.

Check that at least one of the PSU LEDs on the front panel of the switch is lit green. If no LEDs light, refer to the Hardware Reference for troubleshooting information.

Connecting a PWR05 DC power supply

Follow these instructions to connect an AT-PWR05 DC PSU to a DC power supply. Only trained and qualified personnel should connect a DC power supply. You need to connect the supplied DC power cable to an appropriate DC power source.

For centralised DC power connection, the switch should be installed in **restricted access areas only** (such as dedicated equipment rooms or equipment closets) in accordance with Articles 110-16, 110-17, and 110-18 of the National Electrical Code, ANSI/NFPA 70.



Warning When mounting one or two AT-PWR05 DC PSUs to a grounded rack, ensure that the ground level of the rack and the DC power connector are the same .

Power supply specifications:

- functional range 40 to 60V DC, 48V nominal
- supports either positive grounded or negative grounded operation
- a 30Amp certified/listed circuit breaker is required for circuit protection

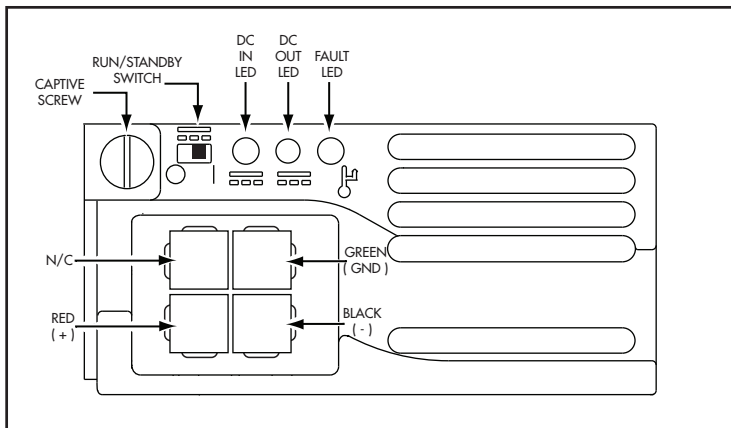

Warning When SwitchBlade x908 devices are connected with VCS stacking cables (either HS-STK-CBL or XEM-STK-CBL), each individual stack member chassis must be additionally grounded by using the rear grounding-terminal on each device. In order to avoid large circulating ground currents, the wires of each grounding cable must be 18 AWG (0.8mm²) or thicker.



1. Ensure that the circuit breaker for the supply circuit and the Run/Standby switch on the PSU are **off** (slide to position O).
2. Plug the DC power cable into the power inlet on the PSU.
3. Connect the supply cable wires to the circuit breaker and switch the circuit breaker ON.
4. Turn on the PSU by sliding in the Run/Standby switch to position I.
5. Confirm that the switch is receiving power.

Check that the PSU LED on the front panel of the switch corresponding to the PSU bay lights green. If the LED does not light green, check the Run/Standby switch. See the Hardware Reference for more troubleshooting information.

Checking LEDs

LEDs on PSUs, fans, and the front panels of switches indicate the operational status of the devices. After you have installed a PSU or fan and have powered on the switch, check the LEDs to verify operation by using the following tables.



PWR01 The following table describes LEDs on the PWR01 and PWR02 power supply units.
PWR02

LED	State	Description
FAULT	Red	The temperature on the PSU has exceeded the limit of 75° C (167° F), or the fan failed.
PWR GOOD	Green	A PSU is installed in the switch and is delivering power.

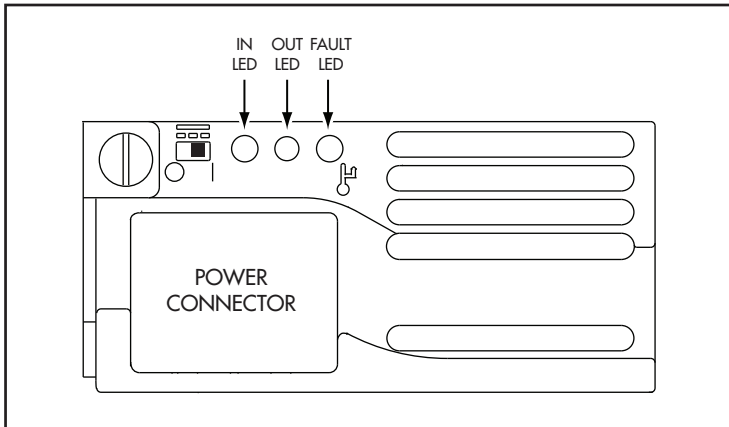

PWR05 The following is a diagram of the LEDs in the PWR05 power supply units:



PWR05 AC The following table describes LEDs on the PWR05 AC power supply unit.

LED	State	Description
 IN	Green	AC input voltage is within 90-264VAC, 47-63Hz.
	Off	AC input voltage is outside the acceptable range.
 OUT	Green	DC output voltage is within 12VDC +/- 10%.
	Off	DC output voltage is outside the acceptable range, or the Standby switch is Off. If a fault occurs then the FAULT LED will display and the OUT LED will be Off.
 FAULT	Amber	A fault has occurred. There is either a fan failure, or the temperature has exceeded its limit of 70°C (158°F).
	Off	No fault conditions detected.

PWR05 DC The following table describes LEDs on the PWR05 DC power supply unit.

LED	State	Description
 IN	Green	DC input voltage is within 40VDC to 60VDC.
	Off	DC input voltage is outside the acceptable range.
 OUT	Green	DC output voltage is within 12VDC +/- 10%.
	Off	DC output voltage is outside the acceptable range, or the Standby switch is Off. If a fault occurs then the FAULT LED will display and the OUT LED will be Off.
 FAULT	Amber	A fault has occurred. There is either a fan failure, or the temperature has exceeded its limit of 70°C (158°F).
	Off	No fault conditions detected.

FAN01 The following table describes LEDs on the FAN01 fan-only module.

LED	State	Description
FAULT	Red	The fan has failed.

Removable Power Supply and Fan

FAN03 The following table describes LEDs on the FAN03 chassis fan module.

LED	State	Description
FAN STATUS	Red	The fan has failed.

Switch The following table describes how LEDs on the switch report operations and faults with installed PSUs and FOMs.

LED	State	Description
PSU 1 and PSU 2	Green	The PSU is installed and supplying power to the switch. The voltage output is within specification.
	Red	One of the following: <ul style="list-style-type: none"> The PSU is installed in the switch, and a fan has failed or the PSU has exceeded its recommended temperature threshold of 70°C (158° F). A FOM is installed in the switch and a fan has failed. Note that the x900-12XT/S and SwitchBlade x908 switches do not support FOMs. The bay is empty. Applies to AT-8948, AT-9924Ts, x900-24XT, x900-24XT-N, and x900-24XS switches which require a FOM when only one PSU is installed. Dual PSUs are installed, but the PSU is not receiving power. The standby switch is off (PWR01 DC, PWR05 AC, or PWR05 DC).
	Off	One of the following: <ul style="list-style-type: none"> A FOM is installed and operating at an acceptable speed. Note that the x900-12XT/S and SwitchBlade x908 switches do not support FOMs. On x900-48FE, x900-48FS, AT-9924T and AT-9924SP switches there is no PSU or FOM in this bay. On a SwitchBlade x908 switch there is no PSU in this bay.

Removing a Power Supply Unit or Fan

Follow these instructions to remove a PSU, chassis fan module, FOM or blanking plate.

Before you begin

- Read the safety information for the switch.

Safety information is in the *x900 Series Switch and SwitchBlade® x908 Installation and Safety Guide*. You can download this document from www.alliedtelesis.com/support/software.

- Gather necessary tools and equipment.

You will need an appropriate flat-bladed or Phillips (#1) screwdriver to tighten or loosen the captive screws.



Caution Follow correct anti-static procedures. Failure to do so could damage the PSU, fan, or switch. If you are unsure about correct procedures, contact your authorised Allied Telesis distributor or reseller.



Caution Keep your hands and fingers out of the power supply bays.

To remove a PSU, chassis fan module or FOM



1. If you are removing a PSU, disconnect the power supply.

For AC PSUs, turn off the main power source to the PSU and disconnect the power cable.

For PWR01 DC PSUs, push and release the Run/Standby switch to the Standby (off) position. The Run/Standby switch is in the Run (on) position when it is depressed, and in the Standby (off) position when it is not depressed. Disconnect the DC power supply then disconnect the supply cable wires from the circuit breaker.

For PWR05 DC PSUs, slide the Run/Standby switch to the O (off) position. Disconnect the power supply cable from the power supply.

2. Using a screwdriver, loosen the captive screws until fully loosened.

The following is a diagram of PWR01, PWR02 or FAN01

Removable Power Supply and Fan

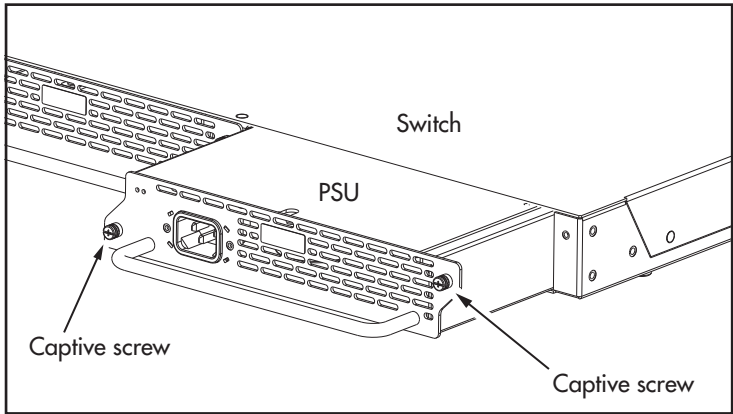

The following is a diagram of PWR05 and FAN03

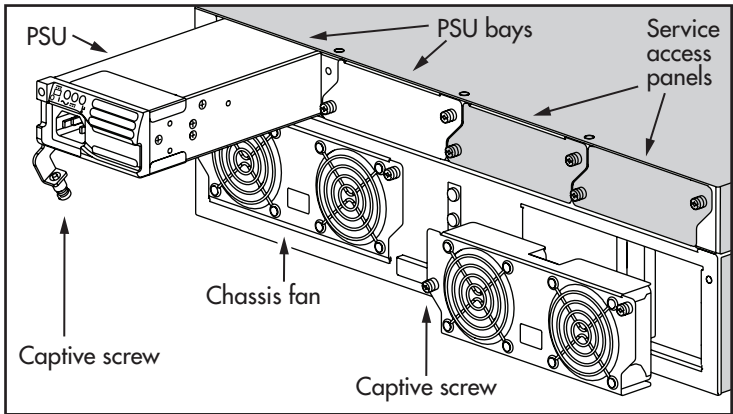

3. Remove the PSU, chassis fan module, FOM or the blanking plate from the switch.
Slide the unit out slowly and carefully. Support the unit from underneath as you remove it, to prevent it from falling.
4. For all units, with the exception of FAN03, cover empty bays with a blanking plate, to prevent dust and debris from overheating or damaging the switch.



Avoid the spinning blades on FAN03. Contact may cause personal injury or damage the unit.



Do not operate the switch for extended periods without functioning chassis fan modules. Doing so will cause the switch to overheat and fail. Component failure occurs after extended over-temperature operation.

Troubleshooting

If the PSU does not function as expected:

- Check that all cable connections are correct and secure.
- On the PWR01 DC model, check that the Run/Standby switch has been pressed and is in the On position.
- On the PWR05, check that the Run/Standby switch has been set to Run (position I).
- Check that the PSU is receiving the correct AC voltage (AC models).
- Check that the PSU is receiving the correct DC voltage (DC models).
- If LEDs indicate a PSU fault, replace the PSU or have your authorised Allied Telesis distributor or reseller service it.

Troubleshooting information is also in the *x900 Series Switch and SwitchBlade® x908 Hardware Reference*. You can download this document from www.alliedtelesis.com/support/software.

Obtaining Documentation and Resources

The complete document set for x900 Series switches and SwitchBlade x908 includes:

- this Installation Guide
- the *x900 Series Switch and SwitchBlade® x908 Installation and Safety Guide*, which describes how to install the switch and includes important safety and statutory information
- the *x900 Series Switch and SwitchBlade® x908 Hardware Reference*, which contains detailed information on x900 Series and SwitchBlade x908 switches and their hardware features
- the *x900 Series Switch and SwitchBlade® x908 Expansion Module Installation Guide*, which describes how to install expansion modules in x900 Series and SwitchBlade x908 switches
- the *AT-9900s Series Switch Expansion Module Installation Guide*, which describes how to install expansion modules in AT-9900s Series switches
- the *x900 Series Switch AlliedWare® Operating System Software Reference*, which contains detailed information on configuring switches running the AlliedWare operating system
- the *AlliedWare Plus™ Operating System Software Reference*, which contains detailed information on configuring switches running the AlliedWare Plus operating system

You can download these documents and updates from www.alliedtelesis.com/support/software.

You need Adobe® Acrobat® Reader® software to view, search, or print these documents. You can download it from www.adobe.com.

Other resources

How-To Notes describe a range of standard Allied Telesis solutions, and include technical tips and guides to configuring specific hardware and software features. You can download the latest How-To Notes from www.alliedtelesis.com/resources/literature/howto.aspx.

MIBs supported by Allied Telesis products can be downloaded from www.alliedtelesis.com/support/software.

Microsoft® Visio® stencils for Allied Telesis products can be downloaded from www.alliedtelesis.com/resources/images/visio.aspx.

Removable Power Supply and Fan

AT-TFTP Server for Windows is a TFTP (*Trivial File Transfer Protocol*) server for transferring software versions, configuration scripts and other files between a PC and the switch. You download AT-TFTP Server from www.alliedtelesis.com/support/software.

CD-ROM

Some products also ship with a CD-ROM containing documentation and resources.

Contacting us

With locations covering all of the established markets in North America, Latin America, Europe, Asia, and the Pacific, Allied Telesis provides localized sales and technical support worldwide. To find the representative nearest you, visit us on the Web at www.alliedtelesis.com.

Standards

Where applicable, the products in this document meet the following standards:

Approval Agency and Requirement		
Safety	UL60950-1 CAN/CSA-C22.2 No. 60950-1-03 EN60950-1 AS/NZS 60950.1	EN 60825-1 EN 60825-2 21 CFR 1040
Electromagnetic	FCC CFR47 Part 15 Class A EN55022 Class A VCCI Class A AS/NZS CISPR22 Class A	CNS 13438 Class A EN61000-3-2/3 EN55024 ETSI 300 386
Immunity	EN55024	
ETSI	ETSI 300 019 ETSI 300 132	
WEEE	Meets requirements of Directive 2002/96/EC of the European Parliament and of the council of 27 January 2003	
RoHS	Meets requirement of Directive 2002/95/EC of the European Parliament and of the council of 27 January 2003	

U.S. Federal Communications Commission

RADIATED ENERGY

Note: This equipment has been tested and found to comply with the limits for a Class A digital device pursuant to Part 15 of the FCC Rules. These limits are designed to provide reasonable protection against harmful interference when the equipment is operated in a commercial environment. This equipment generates, uses, and can radiate radio frequency energy and, if not installed and used in accordance with this instruction manual, may cause harmful interference to radio communications. Operation of this equipment in a residential area is likely to cause harmful interference in which case the user will be required to correct the interference at his own expense.

Note: Modifications or changes not expressly approved by the manufacturer or the FCC can void your right to operate this equipment.

Canadian Department of Communications

This Class A digital apparatus meets all requirements of the Canadian Interference-Causing Equipment Regulations.

Cet appareil numérique de la classe A respecte toutes les exigences du Règlement sur le matériel brouilleur du Canada.

この装置は、クラスA情報技術装置です。この装置を家庭環境で使用する
と電波妨害を引き起こすことがあります。この場合には使用者が適切な対策
を講ずるよう要求されることがあります。 **VCCI- A**

警告使用者：

這是甲類的資訊產品，在居住的環境中使用時，可能會造成射頻
干擾，在這種情況下，使用者會被要求採取某些適當的對策。

BSMI- A

EC Declaration of Conformity

We: **ALLIED TELESIS LABS LIMITED**
27 NAZARETH AVENUE
CHRISTCHURCH 8024
NEW ZEALAND

Declare under our sole legal responsibility that these products:

AT-PWR01, AT-PWR01-80, AT-PWR02, AT-PWR05 and AT-PWR05-80
Power Supply Units

Are in conformity with the essential requirements of directives:

- 2006/95/EC Low Voltage Directive
- 2004/108/EC Electromagnetic Compatibility (EMC) Directive

with reference to the following harmonised standards:

- EN55022: 1998 including A1:2000 and A2:2003
Information Technology Equipment—Radio disturbance
- EN55024: 1998 including A1:2001 and A2:2003
Information Technology Equipment—Immunity characteristics—Limits and
methods of measurement
- EN60950-1: 2001 including A1:2004
Information Technology Equipment including electrical business
equipment—General Requirements
- EN61000-3-2: 2000 including A2:2005
Electromagnetic compatibility (EMC)—part 3-2: Limits for harmonic current
emissions (equipment input current up to and including 16A per phase)
- EN61000-3-3: 1995 including A1:2001 and A2:2005
Electromagnetic compatibility (EMC)—part 3-3: Limitation of voltage
fluctuations and flicker in low-voltage supply systems for equipment with
rated current up to 16A

Name: Graham Walker
On behalf of the Manufacturer
Signature:

Position:
Senior Engineering
Product Manager



Date of issue: 15 September 2009
Place of issue: 27 Nazareth Ave